



TBM 930

PILOT'S INFORMATION MANUAL

P/N DMJPIPYEE0 - Edition 1 - Revision 5

▲ CAUTION ▲

This information manual is a non-official copy of the pilot's operating handbook and may be used for general information purposes only. It is not kept current and therefore cannot be used as a substitute for airworthiness authorities approved manual which is the only one intended for operation of the airplane.

The list of effective pages in this manual corresponds to that of the basic Pilot's Operating Handbook.



The content of this document is the property of DAHER AEROSPACE. It is supplied in confidence and commercial security of its contents must be maintained.

It must not be used for any purpose other than that for which it is supplied, nor may information contained in it be disclosed to unauthorized persons. It must not be reproduced nor transmitted in any form in whole or in part without permission in writing from the owners of the Copyright.

Information in this document is subject to change without notice.

© 2018, 2019, 2020, 2021 - DAHER AEROSPACE

All rights reserved

DAHER AEROSPACE

Customer care
65921 TARBES CEDEX 9
FRANCE

Printed in FRANCE

PIM - DO NOT USE FOR FLIGHT OPERATIONS

List of amendments

- Revision 1 dated April 3, 2018

Pages	Description
Title, Approval page	Change of legal entity name from SOCATA SAS to DAHER AEROSPACE
0.9 and 0.10	List of amendments Revision 1
0.11 thru 0.20	List of effective pages and validities
6.5.1	Reference to SOCATA deleted

List of amendments

Revision 2 dated April 8, 2019

Pages	Description
Title	Updating of copyright date
0.1	Approval page
0.4	Website address updating
0.10 thru 0.12	List of amendments
0.13 thru 0.22	List of effective pages
1.4.7	Deletion of "ESI" abbreviation
2.3.3, 4.5.24	Addition of CAUTION related to maximum time of sideslip condition
2.6.9, 2.6.10	Integration of AD2000-02-29 & AD98-04-22 data
2.9.5	Modification of placard under R.H. control wheel
3.1.4, 3.12.28 thru 3.12.30	Modification of annunciations visual
3.3.1 and 3.3.2	Modification of "Engine failure after rotation" procedure
3.3.3	Modification of "Engine failure in flight" procedure
3.3.4	Modification of "OIL PRESS or OIL PRESS" procedure
3.3.5 thru 3.3.7	Modification of "Engine regulation discrepancy, power loss, throttle control loss" procedure
3.3.8	Modification of "Governor control not operating" procedure
3.3.8	Modification of "Excessive propeller rotation speed" procedure
3.3.11	Modification of "CHIP" procedure
3.3.12	Modification of "OIL TEMP" procedure
3.4.2, 3.4.3	Modification of "Air start procedures" procedure

List of amendments

Revision 2 dated April 08, 2019 (Cont'd)

Pages	Description
3.9.2, 3.9.3	Deletion of right windshield restriction for deicing systems
3.10.3	Modification of "GAS EVENT" procedure
3.10.7	Addition of Pre-MOD70-0657-34 validity
3.10.8	Addition of "EDM" procedure, Post-MOD70-0657-34
3.12.27	Modification of "Left PFD failure" procedure
3.12.34	Modification of WXR breaker name
4.3.3	Modification of test sequence in "Before starting engine" procedure
4.4.1	Modification of the details of the covers to be removed
4.4.7	Preflight inspection : deletion of action on TEST push-button
4.4.18, 4.4.22	Operation related to OXYGEN CAS message moved from "Inside inspection" procedure to "Before starting engine" procedure
4.4.19	Deletion of the Note related to PARK BRAKE
4.4.22	Audio alarms and DE ICE SYSTEM lights check replaced by operation on TEST push-button
4.5.4	Deletion of data related to OAT below -35°C
6.4.18	Modification of ARM and CG values for Zero fuel weight
6.4.21, 6.4.22	Updating of equipment
7.1.1, 7.3.1 thru 7.3.3, 7.6.7, 7.8.14, 7.13.3	Replacement of the reference to the Cockpit Reference Guide by the reference to the Pilot's Guide
7.3.2	Addition of "ADVISORY" category
7.3.32	Belts and harnesses : addition of airbags data

List of amendments

Revision 2 dated April 08, 2019 (Cont'd)

Pages	Description
7.6.10	Engine air inlet : modification/addition of data related to vane deflection
7.8.19	Cabin lighting : modification/deletion of data related to floodlights
7.14.3	Addition of weather radar data
2.0.1, 2.6.6, 2.6.11 thru 2.6.18, 3.A.1 thru 3.A.3, 3.0.1, 3.0.3, 3.0.5, 3.1.1, 3.3.9, 3.3.10, 3.9.7, 3.9.11, 3.10.3 thru 3.10.5, 3.10.9 thru 3.10.14, 3.12.9 thru 3.12.11, 3.12.31 thru 3.12.36, 4.0.1, 4.0.2, 4.3.8, 4.4.8 thru 4.4.16, 4.4.19, 4.4.20 thru 4.4.70, 4.5.3, 4.5.25, 7.3.33, 7.10.7	Terminology, text moving and/or presentation

List of amendments

Revision 3 dated February 14, 2020

Pages	Description
Title	Modification of the date of the copyright
0.1	Approval page
0.13 to 0.16	List of amendments
0.17 to 0.26	List of effective pages
1.1.1	Addition of requirement compliance for transponder and ADS-B OUT systems
2.3.1	Correction of ITT limitation during start
2.8.2	Correction of engine instrument markings
2.9.2	Correction of the location for small cargo placard
2.9.11	Update of MOD number for coat hanger
3.9.11	Removal of indication requiring to press a key on MD302
3.10.6, 3.10.7	Addition of instruction to contact maintenance department
3.10.12	Precision on how to reduce cabin differential pressure
3.11.7	Addition of symptoms
3.12.14	Addition of instruction to use standby instrument
4.3.9, 4.3.10	Modification of rotation airspeed graph
4.4.3	Precision for time with PROP DE ICE switch ON
4.4.45, 4.4.64	Modification of rotation airspeed graph
4.4.59	Removal of minimum torque recommendation
4.5.8, 4.5.11	Precision for time with PROP DE ICE switch ON
4.5.28	Deletion of paragraph "Non precision approach with coupled autopilot"

List of amendments

Revision 3 dated February 14, 2020 (Cont'd)

Pages	Description
5.4.1	Addition of a note explaining the curve for pressurization envelope
5.9.2 to 5.9.4	Modification of rotation airspeed graph
5.10.1, 5.10.2	Correction of conditions regarding BLEED HI message
5.10.3 to 5.10.8	Integration of a fixed torque reduction instruction when BLEED HI message ON with associated impacts on climb performance
5.11.2 to 5.11.8, 5.11.10 to 5.11.16	Integration of a fixed torque reduction instruction when BLEED HI message ON with associated impacts on airspeed
7.0.2, 7.9.1 to 7.9.15	Air conditioning and pressurization system : - Rewording of description paragraph - Integration of modifications due to GASC software evolution (MOD70-0689-21)
7.0.3, 7.14.10 to 7.14.14	New layout of GARMIN Integrated Flight Deck approaches paragraphs
7.5.9	Addition of CAUTION and instructions related to parking brake release
7.5.11	Correction of brake system diagram (pipe between park brake valve and right wing)
7.11.1	Addition of information about alternate static pressure supply to instruments
7.13.2	Precision for time with PROP DE ICE switch ON
7.14.8	ADS-B OUT function : Correction of the description of the appearance of messages in the avionics to indicate failure of transponders

List of amendments

Revision 3 dated February 14, 2020 (Cont'd)

Pages	Description
2.6.2, 2.9.3, 3.1.1, 3.9.4, 3.9.5, 3.11.6, 3.12.12, 3.12.14, 4.4.24, 7.3.33, 7.3.34, 7.9.16 to 7.9.22, 7.14.9 to 7.14.14	Terminology, text moving and/or presentation

List of amendments

Revision 4 dated June 15, 2020

Pages	Description
0.1	Approval page
0.16 to 0.18	List of amendments
0.19 to 0.28	List of effective pages
	Introduction of data in addition to those already existing in this POH TBM 930 at Edition 1, concerning G3000 2018 system retrofit for airplanes from S/N 1111 to 1215, equipped with MOD70-0549-00 Version E :
3.0.3, 3.10.7	- Addition of "Before GDU v20.92 software" in the procedure validity (MOD70-0549-00E)
3.0.3, 3.10.8	- Addition of "After GDU v20.92 software" in the procedure validity (MOD70-0549-00E)
	Introduction of data to make this POH TBM 930 at Edition 1 valid for airplanes from S/N 1111 to 1215, equipped with MOD70-0549-00 Version E :
2.1.1	- Addition of Pilot's Guide reference for airplanes up to S/N 1215
2.6.2	- Addition of GPS equipment references for airplanes up to S/N 1215
2.9.2	- Modification of the location of small cargo net placard to cover airplanes up to S/N 1215
2.9.11	- Addition of coat hanger placard (MOD70-0557-25C) to cover airplanes up to S/N 1215
3.9.9, 7.8.8	- Addition of validity for seats heaters breakers on BUS 4
4.3.1, 4.3.6, 4.3.19, 4.4.3, 4.4.19, 4.4.35, 4.4.67, 8.9.2, 8.9.3, 8.9.5, 8.9.7	- Addition of validity for seats heaters
6.4.4, 6.4.5	- Addition of airplane loading form for airplanes up to S/N 1159
6.4.10, 6.4.11, 6.4.14, 6.4.15	- Addition of weight and balance form and diagram for airplanes up to S/N 1159

List of amendments

Revision 4 dated June 15, 2020 (Cont'd)

Pages	Description
6.4.19 to 6.4.21	- Addition of a weight and balance sample (m,kg) for airplanes up to S/N 1159
6.4.27, 6.4.28	- Addition of upholstery and cabinets data for airplanes up to S/N 1159
6.4.28, 6.4.29	- Addition of seats data for airplanes up to S/N 1214
7.0.3, 7.10.7	- Addition of validity for O ₂ smart mike mask
7.0.3, 7.14.8	- Addition of validity for FS510
7.0.3, 7.14.9	- Addition of validity for FASTBOX
7.3.1, 7.3.2	- Addition of validity for seats heaters and hourmeter
7.3.8	- Addition of validity for seats heaters, hourmeter and servicing plugs
7.3.12, 7.3.13	- Addition of illustration for right instrument panel of airplanes up to S/N 1159
7.3.28	- Addition of validity for seats heaters description paragraph
7.8.13	- Addition of breakers panel for airplanes up to S/N 1159
7.8.19	- Modification of illustration of external lighting controls to cover airplanes with different type of taxi light switch
	Other modifications :
5.0.1	- Correction of page numbering for section 5.8
6.4.6, 6.4.7	- Addition of validity "From S/N 1160" for existing airplane loading form and modification of intermediate/rear seats weight (weight given without seat heating system)
6.4.12, 6.4.16	- Addition of validity "From S/N 1160" for existing weight and balance form and modification of intermediate/rear seats weight (weight given without seat heating system)
6.4.23, 6.4.24	- Addition of validity "From S/N 1160" for existing weight and balance sample (in, lbs)

List of amendments

Revision 4 dated June 15, 2020 (Cont'd)

Pages	Description
6.4.28, 6.4.29	- Addition of validity on seats for airplanes from S/N 1215
7.3.14, 7.3.15	- Addition of validity on illustration for right instrument panel of airplanes from S/N 1160
7.8.14	- Addition of validity for airplanes up to S/N 1160
8.9.4, 8.9.6	- Addition of notes for influence of blanking device and plug arrangements on cabin comfort
2.0.1, 2.6.3 to 2.6.20, 4.3.2, 4.3.19, 4.3.20, 4.4.17, 4.4.35, 6.0.1, 6.4.2, 6.4.8, 6.4.9, 6.4.13, 6.4.17, 6.4.18, 6.4.22 to 6.4.30, 7.0.1, 7.0.2, 7.2.5, 7.3.1, 7.3.3, 7.3.16 to 7.3.42, 7.5.11, 7.8.10 to 7.8.22, 7.10.1, 7.10.7, 8.9.8 to 8.9.14	Terminology, text moving and/or presentation

List of amendments

Revision 5 dated January 20, 2021

Pages	Description
Title	Updating of copyright date
0.1	Approval page
0.19, 0.20	List of amendments
0.21 to 0.30	List of effective pages
1.4.7, 1.4.8	Addition of abbreviations
3.4.2, 3.4.3	Update of Air start procedure : instruction to keep AUX BP switch to ON for the remainder of the flight
3.10.7, 3.10.8	Update of validity (MOD70-0549-00F)
3.12.12, 3.12.13	Update of Oxygen use procedure with correction of mask controls
4.3.20, 4.4.70	Update of Shutdown procedure : <ul style="list-style-type: none">- Addition of instructions to install external covers on the airplane- Correction of the delay before checking engine oil level
4.4.31	Removal of note related to maintenance actions
4.4.36	Update of In-flight available oxygen quantity procedure : Clarification of the procedure validity in the title
4.5.24	Correction of approach airspeed and clarification about speed correction for gust amplitude
7.10.1 to 7.10.3, 7.10.5 to 7.10.9	Update of the emergency oxygen system description

List of amendments

Revision 5 dated January 20, 2021 (Cont'd)

Pages	Description
8.7.10 1.4.7 to 1.4.10, 2.3.3, 2.6.9, 2.8.1, 3.9.5, 3.10.7, 3.10.8 4.3.20, 4.4.17, 4.4.32, 4.4.35, 4.4.36, 4.4.65, 4.4.68, 4.4.70, 4.5.16, 4.5.24, 5.9.1, 5.9.4, 7.0.2, 7.3.28, 7.5.2, 7.5.9, 7.6.5, 7.7.5, 7.7.8, 7.8.17, 7.9.1 to 7.9.14, 7.9.21, 7.10.1 to 7.10.10, 7.11.1, 7.11.2, 7.11.4, 7.14.13, 7.14.14, 8.7.8 to 8.7.10, 8.9.1, 8.9.8	Addition of information related to the minimum oxygen cylinder pressure and requirement to purge the cylinder Terminology, text moving and/or presentation

Table of contents

	Section
General	1
Limitations	2
Emergency procedures	3
Normal procedures	4
Performance	5
Weight and balance	6
Description	7
Airplane handling, servicing and maintenance	8
Supplements	9

List of effective pages and validities
Original issue of January 15, 2018
Airplane equipped with MOD70-0549-00

P/N DMJFM00EE1R5EN

Page No.	Edit./Rev. No.	Rev. Date	Page No.	Edit./Rev. No.	Rev. Date
■ Title	1-5	JAN 21	0.18	1-4	JUN 20
			0.19	1-5	JAN 21
1	1-0	JAN 18	0.20	1-5	JAN 21
2	1-0	JAN 18	0.21	1-5	JAN 21
			0.22	1-5	JAN 21
A	1-0	JAN 18	0.23	1-5	JAN 21
B	1-0	JAN 18	0.24	1-5	JAN 21
C	1-0	JAN 18	0.25	1-5	JAN 21
D	1-0	JAN 18	0.26	1-5	JAN 21
			0.27	1-5	JAN 21
■ 0.1	1-5	JAN 21	0.28	1-5	JAN 21
0.2	1-0	JAN 18	0.29	1-5	JAN 21
0.3	1-0	JAN 18	0.30	1-5	JAN 21
0.4	1-2	APR 19			
0.5	1-0	JAN 18	1.0.1	1-0	JAN 18
0.6	1-0	JAN 18	1.0.2	1-0	JAN 18
0.7	1-0	JAN 18			
0.8	1-0	JAN 18	1.1.1	1-3	FEB 20
0.9	1-1	APR 18	1.1.2	1-0	JAN 18
0.10	1-2	APR 19			
0.11	1-2	APR 19	1.2.1	1-0	JAN 18
0.12	1-2	APR 19	1.2.2	1-0	JAN 18
0.13	1-3	FEB 20			
0.14	1-3	FEB 20	1.3.1	1-0	JAN 18
0.15	1-3	FEB 20	1.3.2	1-0	JAN 18
0.16	1-4	JUN 20	1.3.3	1-0	JAN 18
0.17	1-4	JUN 20	1.3.4	1-0	JAN 18

Page No.	Edit./Rev. No.	Rev. Date	Page No.	Edit./Rev. No.	Rev. Date
			2.6.4	1-4	JUN 20
1.4.1	1-0	JAN 18	2.6.5	1-4	JUN 20
1.4.2	1-0	JAN 18	2.6.6	1-4	JUN 20
1.4.3	1-0	JAN 18	2.6.7	1-4	JUN 20
1.4.4	1-0	JAN 18	2.6.8	1-4	JUN 20
1.4.5	1-0	JAN 18	2.6.9	1-5	JAN 21
1.4.6	1-0	JAN 18	2.6.10	1-4	JUN 20
1.4.7	1-5	JAN 21	2.6.11	1-4	JUN 20
1.4.8	1-5	JAN 21	2.6.12	1-4	JUN 20
1.4.9	1-5	JAN 21	2.6.13	1-4	JUN 20
1.4.10	1-5	JAN 21	2.6.14	1-4	JUN 20
			2.6.15	1-4	JUN 20
1.5.1	1-0	JAN 18	2.6.16	1-4	JUN 20
1.5.2	1-0	JAN 18	2.6.17	1-4	JUN 20
1.5.3	1-0	JAN 18	2.6.18	1-4	JUN 20
1.5.4	1-0	JAN 18	2.6.19	1-4	JUN 20
			2.6.20	1-4	JUN 20
1.6.1	1-0	JAN 18			
1.6.2	1-0	JAN 18	2.7.1	1-0	JAN 18
			2.7.2	1-0	JAN 18
2.0.1	1-4	JUN 20			
2.0.2	1-0	JAN 18	2.8.1	1-5	JAN 21
			2.8.2	1-3	FEB 20
2.1.1	1-4	JUN 20			
2.1.2	1-0	JAN 18	2.9.1	1-0	JAN 18
			2.9.2	1-4	JUN 20
2.2.1	1-0	JAN 18	2.9.3	1-3	FEB 20
2.2.2	1-0	JAN 18	2.9.4	1-0	JAN 18
			2.9.5	1-2	APR 19
2.3.1	1-3	FEB 20	2.9.6	1-0	JAN 18
2.3.2	1-0	JAN 18	2.9.7	1-0	JAN 18
2.3.3	1-5	JAN 21	2.9.8	1-0	JAN 18
2.3.4	1-0	JAN 18	2.9.9	1-0	JAN 18
			2.9.10	1-0	JAN 18
2.4.1	1-0	JAN 18	2.9.11	1-4	JUN 20
2.4.2	1-0	JAN 18	2.9.12	1-0	JAN 18
2.5.1	1-0	JAN 18	3.A.1	1-2	APR 19
2.5.2	1-0	JAN 18	3.A.2	1-2	APR 19
			3.A.3	1-2	APR 19
2.6.1	1-0	JAN 18	3.A.4	1-0	JAN 18
2.6.2	1-4	JUN 20			
2.6.3	1-4	JUN 20	3.0.1	1-2	APR 19

Pilot's Operating Handbook

Page No.	Edit./Rev. No.	Rev. Date	Page No.	Edit./Rev. No.	Rev. Date
3.0.2	1-0	JAN 18			
3.0.3	1-4	JUN 20	3.7.1	1-0	JAN 18
3.0.4	1-0	JAN 18	3.7.2	1-0	JAN 18
3.0.5	1-2	APR 19	3.7.3	1-0	JAN 18
3.0.6	1-0	JAN 18	3.7.4	1-0	JAN 18
			3.7.5	1-0	JAN 18
3.1.1	1-3	FEB 20	3.7.6	1-0	JAN 18
3.1.2	1-0	JAN 18	3.7.7	1-0	JAN 18
3.1.3	1-0	JAN 18	3.7.8	1-0	JAN 18
3.1.4	1-2	APR 19	3.7.9	1-0	JAN 18
			3.7.10	1-0	JAN 18
3.2.1	1-0	JAN 18	3.7.11	1-0	JAN 18
3.2.2	1-0	JAN 18	3.7.12	1-0	JAN 18
			3.7.13	1-0	JAN 18
3.3.1	1-2	APR 19	3.7.14	1-0	JAN 18
3.3.2	1-2	APR 19	3.7.15	1-0	JAN 18
3.3.3	1-2	APR 19	3.7.16	1-0	JAN 18
3.3.4	1-2	APR 19			
3.3.5	1-2	APR 19	3.8.1	1-0	JAN 18
3.3.6	1-2	APR 19	3.8.2	1-0	JAN 18
3.3.7	1-2	APR 19	3.8.3	1-0	JAN 18
3.3.8	1-2	APR 19	3.8.4	1-0	JAN 18
3.3.9	1-2	APR 19	3.8.5	1-0	JAN 18
3.3.10	1-2	APR 19	3.8.6	1-0	JAN 18
3.3.11	1-2	APR 19	3.8.7	1-0	JAN 18
3.3.12	1-2	APR 19	3.8.8	1-0	JAN 18
3.4.1	1-0	JAN 18	3.9.1	1-0	JAN 18
3.4.2	1-5	JAN 21	3.9.2	1-2	APR 19
3.4.3	1-5	JAN 21	3.9.3	1-2	APR 19
3.4.4	1-0	JAN 18	3.9.4	1-3	FEB 20
			3.9.5	1-5	JAN 21
3.5.1	1-0	JAN 18	3.9.6	1-0	JAN 18
3.5.2	1-0	JAN 18	3.9.7	1-2	APR 19
3.5.3	1-0	JAN 18	3.9.8	1-0	JAN 18
3.5.4	1-0	JAN 18	3.9.9	1-4	JUN 20
3.5.5	1-0	JAN 18	3.9.10	1-0	JAN 18
3.5.6	1-0	JAN 18	3.9.11	1-3	FEB 20
			3.9.12	1-0	JAN 18
3.6.1	1-0	JAN 18			
3.6.2	1-0	JAN 18	3.10.1	1-0	JAN 18
3.6.3	1-0	JAN 18	3.10.2	1-0	JAN 18
3.6.4	1-0	JAN 18	3.10.3	1-2	APR 19

Page No.	Edit./Rev. No.	Rev. Date	Page No.	Edit./Rev. No.	Rev. Date
3.10.4	1-2	APR 19	3.12.23	1-0	JAN 18
3.10.5	1-2	APR 19	3.12.24	1-0	JAN 18
3.10.6	1-3	FEB 20	3.12.25	1-0	JAN 18
3.10.7	1-5	JAN 21	3.12.26	1-0	JAN 18
3.10.8	1-5	JAN 21	3.12.27	1-2	APR 19
3.10.9	1-2	APR 19	3.12.28	1-2	APR 19
3.10.10	1-2	APR 19	3.12.29	1-2	APR 19
3.10.11	1-2	APR 19	3.12.30	1-2	APR 19
3.10.12	1-3	FEB 20	3.12.31	1-2	APR 19
3.10.13	1-2	APR 19	3.12.32	1-2	APR 19
3.10.14	1-2	APR 19	3.12.33	1-2	APR 19
			3.12.34	1-2	APR 19
3.11.1	1-0	JAN 18	3.12.35	1-2	APR 19
3.11.2	1-0	JAN 18	3.12.36	1-2	APR 19
3.11.3	1-0	JAN 18			
3.11.4	1-0	JAN 18	4.0.1	1-2	APR 19
3.11.5	1-0	JAN 18	4.0.2	1-2	APR 19
3.11.6	1-3	FEB 20			
3.11.7	1-3	FEB 20	4.1.1	1-0	JAN 18
3.11.8	1-0	JAN 18	4.1.2	1-0	JAN 18
3.12.1	1-0	JAN 18	4.2.1	1-0	JAN 18
3.12.2	1-0	JAN 18	4.2.2	1-0	JAN 18
3.12.3	1-0	JAN 18			
3.12.4	1-0	JAN 18	4.3.1	1-4	JUN 20
3.12.5	1-0	JAN 18	4.3.2	1-4	JUN 20
3.12.6	1-0	JAN 18	4.3.3	1-2	APR 19
3.12.7	1-0	JAN 18	4.3.4	1-0	JAN 18
3.12.8	1-0	JAN 18	4.3.5	1-0	JAN 18
3.12.9	1-2	APR 19	4.3.6	1-4	JUN 20
3.12.10	1-2	APR 19	4.3.7	1-0	JAN 18
3.12.11	1-2	APR 19	4.3.8	1-2	APR 19
3.12.12	1-5	JAN 21	4.3.9	1-3	FEB 20
3.12.13	1-5	JAN 21	4.3.10	1-3	FEB 20
3.12.14	1-3	FEB 20	4.3.11	1-0	JAN 18
3.12.15	1-0	JAN 18	4.3.12	1-0	JAN 18
3.12.16	1-0	JAN 18	4.3.13	1-0	JAN 18
3.12.17	1-0	JAN 18	4.3.14	1-0	JAN 18
3.12.18	1-0	JAN 18	4.3.15	1-0	JAN 18
3.12.19	1-0	JAN 18	4.3.16	1-0	JAN 18
3.12.20	1-0	JAN 18	4.3.17	1-0	JAN 18
3.12.21	1-0	JAN 18	4.3.18	1-0	JAN 18
3.12.22	1-0	JAN 18	4.3.19	1-4	JUN 20

Pilot's Operating Handbook

Page No.	Edit./Rev. No.	Rev. Date	Page No.	Edit./Rev. No.	Rev. Date
■ 4.3.20	1-5	JAN 21	4.4.42	1-2	APR 19
			4.4.43	1-2	APR 19
4.4.1	1-2	APR 19	4.4.44	1-2	APR 19
4.4.2	1-0	JAN 18	4.4.45	1-3	FEB 20
4.4.3	1-4	JUN 20	4.4.46	1-2	APR 19
4.4.4	1-0	JAN 18	4.4.47	1-2	APR 19
4.4.5	1-0	JAN 18	4.4.48	1-2	APR 19
4.4.6	1-0	JAN 18	4.4.49	1-2	APR 19
4.4.7	1-2	APR 19	4.4.50	1-2	APR 19
4.4.8	1-2	APR 19	4.4.51	1-2	APR 19
4.4.9	1-2	APR 19	4.4.52	1-2	APR 19
4.4.10	1-2	APR 19	4.4.53	1-2	APR 19
4.4.11	1-2	APR 19	4.4.54	1-2	APR 19
4.4.12	1-2	APR 19	4.4.55	1-2	APR 19
4.4.13	1-2	APR 19	4.4.56	1-2	APR 19
4.4.14	1-2	APR 19	4.4.57	1-2	APR 19
4.4.15	1-2	APR 19	4.4.58	1-2	APR 19
4.4.16	1-2	APR 19	4.4.59	1-3	FEB 20
■ 4.4.17	1-5	JAN 21	4.4.60	1-2	APR 19
4.4.18	1-2	APR 19	4.4.61	1-2	APR 19
4.4.19	1-4	JUN 20	4.4.62	1-2	APR 19
4.4.20	1-2	APR 19	4.4.63	1-2	APR 19
4.4.21	1-2	APR 19	4.4.64	1-3	FEB 20
4.4.22	1-2	APR 19	■ 4.4.65	1-5	JAN 21
4.4.23	1-2	APR 19	4.4.66	1-2	APR 19
4.4.24	1-3	FEB 20	4.4.67	1-4	JUN 20
4.4.25	1-2	APR 19	■ 4.4.68	1-5	JAN 21
4.4.26	1-2	APR 19	4.4.69	1-2	APR 19
4.4.27	1-2	APR 19	■ 4.4.70	1-5	JAN 21
4.4.28	1-2	APR 19			
4.4.29	1-2	APR 19	4.5.1	1-0	JAN 18
4.4.30	1-2	APR 19	4.5.2	1-0	JAN 18
■ 4.4.31	1-5	JAN 21	4.5.3	1-2	APR 19
4.4.32	1-5	JAN 21	4.5.4	1-2	APR 19
4.4.33	1-2	APR 19	4.5.5	1-0	JAN 18
4.4.34	1-2	APR 19	4.5.6	1-0	JAN 18
■ 4.4.35	1-5	JAN 21	4.5.7	1-0	JAN 18
4.4.36	1-5	JAN 21	4.5.8	1-3	FEB 20
4.4.37	1-2	APR 19	4.5.9	1-0	JAN 18
4.4.38	1-2	APR 19	4.5.10	1-0	JAN 18
4.4.39	1-2	APR 19	4.5.11	1-3	FEB 20
4.4.40	1-2	APR 19	4.5.12	1-0	JAN 18
4.4.41	1-2	APR 19	4.5.13	1-0	JAN 18

Page No.	Edit./Rev. No.	Rev. Date	Page No.	Edit./Rev. No.	Rev. Date
4.5.14	1-0	JAN 18	5.8.4	1-0	JAN 18
4.5.15	1-0	JAN 18	5.8.5	1-0	JAN 18
■ 4.5.16	1-5	JAN 21	5.8.6	1-0	JAN 18
4.5.17	1-0	JAN 18	5.8.7	1-0	JAN 18
4.5.18	1-0	JAN 18	5.8.8	1-0	JAN 18
4.5.19	1-0	JAN 18	5.8.9	1-0	JAN 18
4.5.20	1-0	JAN 18	5.8.10	1-0	JAN 18
4.5.21	1-0	JAN 18	5.8.11	1-0	JAN 18
4.5.22	1-0	JAN 18	5.8.12	1-0	JAN 18
4.5.23	1-0	JAN 18			
■ 4.5.24	1-5	JAN 21	■ 5.9.1	1-5	JAN 21
4.5.25	1-2	APR 19	5.9.2	1-3	FEB 20
4.5.26	1-0	JAN 18	5.9.3	1-3	FEB 20
4.5.27	1-0	JAN 18	■ 5.9.4	1-5	JAN 21
4.5.28	1-3	FEB 20			
			5.10.1	1-3	FEB 20
5.0.1	1-4	JUN 20	5.10.2	1-3	FEB 20
5.0.2	1-0	JAN 18	5.10.3	1-3	FEB 20
			5.10.4	1-3	FEB 20
5.1.1	1-0	JAN 18	5.10.5	1-3	FEB 20
5.1.2	1-0	JAN 18	5.10.6	1-3	FEB 20
			5.10.7	1-3	FEB 20
5.2.1	1-0	JAN 18	5.10.8	1-3	FEB 20
5.2.2	1-0	JAN 18	5.10.9	1-0	JAN 18
			5.10.10	1-0	JAN 18
5.3.1	1-0	JAN 18			
5.3.2	1-0	JAN 18	5.11.1	1-0	JAN 18
			5.11.2	1-3	FEB 20
5.4.1	1-3	FEB 20	5.11.3	1-3	FEB 20
5.4.2	1-0	JAN 18	5.11.4	1-3	FEB 20
			5.11.5	1-3	FEB 20
5.5.1	1-0	JAN 18	5.11.6	1-3	FEB 20
5.5.2	1-0	JAN 18	5.11.7	1-3	FEB 20
			5.11.8	1-3	FEB 20
5.6.1	1-0	JAN 18	5.11.9	1-0	JAN 18
5.6.2	1-0	JAN 18	5.11.10	1-3	FEB 20
			5.11.11	1-3	FEB 20
5.7.1	1-0	JAN 18	5.11.12	1-3	FEB 20
5.7.2	1-0	JAN 18	5.11.13	1-3	FEB 20
			5.11.14	1-3	FEB 20
5.8.1	1-0	JAN 18	5.11.15	1-3	FEB 20
5.8.2	1-0	JAN 18	5.11.16	1-3	FEB 20
5.8.3	1-0	JAN 18	5.11.17	1-0	JAN 18

Pilot's Operating Handbook

Page No.	Edit./Rev. No.	Rev. Date	Page No.	Edit./Rev. No.	Rev. Date
5.11.18	1-0	JAN 18	6.4.13	1-4	JUN 20
5.11.19	1-0	JAN 18	6.4.14	1-4	JUN 20
5.11.20	1-0	JAN 18	6.4.15	1-4	JUN 20
5.11.21	1-0	JAN 18	6.4.16	1-4	JUN 20
5.11.22	1-0	JAN 18	6.4.17	1-4	JUN 20
			6.4.18	1-4	JUN 20
5.12.1	1-0	JAN 18	6.4.19	1-4	JUN 20
5.12.2	1-0	JAN 18	6.4.20	1-4	JUN 20
			6.4.21	1-4	JUN 20
5.13.1	1-0	JAN 18	6.4.22	1-4	JUN 20
5.13.2	1-0	JAN 18	6.4.23	1-4	JUN 20
			6.4.24	1-4	JUN 20
5.14.1	1-0	JAN 18	6.4.25	1-4	JUN 20
5.14.2	1-0	JAN 18	6.4.26	1-4	JUN 20
5.14.3	1-0	JAN 18	6.4.27	1-4	JUN 20
5.14.4	1-0	JAN 18	6.4.28	1-4	JUN 20
			6.4.29	1-4	JUN 20
6.0.1	1-4	JUN 20	6.4.30	1-4	JUN 20
6.0.2	1-0	JAN 18			
			6.5.1	1-1	APR 18
6.1.1	1-0	JAN 18	6.5.2	1-0	JAN 18
6.1.2	1-0	JAN 18			
			7.0.1	1-4	JUN 20
6.2.1	1-0	JAN 18	7.0.2	1-5	JAN 21
6.2.2	1-0	JAN 18	7.0.3	1-4	JUN 20
			7.0.4	1-0	JAN 18
6.3.1	1-0	JAN 18			
6.3.2	1-0	JAN 18	7.1.1	1-2	APR 19
6.3.3	1-0	JAN 18	7.1.2	1-0	JAN 18
6.3.4	1-0	JAN 18			
			7.2.1	1-0	JAN 18
6.4.1	1-0	JAN 18	7.2.2	1-0	JAN 18
6.4.2	1-4	JUN 20	7.2.3	1-0	JAN 18
6.4.3	1-0	JAN 18	7.2.4	1-0	JAN 18
6.4.4	1-4	JUN 20	7.2.5	1-4	JUN 20
6.4.5	1-4	JUN 20	7.2.6	1-0	JAN 18
6.4.6	1-4	JUN 20	7.2.7	1-0	JAN 18
6.4.7	1-4	JUN 20	7.2.8	1-0	JAN 18
6.4.8	1-4	JUN 20			
6.4.9	1-4	JUN 20	7.3.1	1-4	JUN 20
6.4.10	1-4	JUN 20	7.3.2	1-4	JUN 20
6.4.11	1-4	JUN 20	7.3.3	1-4	JUN 20
6.4.12	1-4	JUN 20	7.3.4	1-0	JAN 18

Page No.	Edit./Rev. No.	Rev. Date	Page No.	Edit./Rev. No.	Rev. Date
7.3.5	1-0	JAN 18	7.4.5	1-0	JAN 18
7.3.6	1-0	JAN 18	7.4.6	1-0	JAN 18
7.3.7	1-0	JAN 18	7.4.7	1-0	JAN 18
7.3.8	1-4	JUN 20	7.4.8	1-0	JAN 18
7.3.9	1-0	JAN 18	7.4.9	1-0	JAN 18
7.3.10	1-0	JAN 18	7.4.10	1-0	JAN 18
7.3.11	1-0	JAN 18	7.4.11	1-0	JAN 18
7.3.12	1-4	JUN 20	7.4.12	1-0	JAN 18
7.3.13	1-4	JUN 20	7.4.13	1-0	JAN 18
7.3.14	1-4	JUN 20	7.4.14	1-0	JAN 18
7.3.15	1-4	JUN 20	7.4.15	1-0	JAN 18
7.3.16	1-4	JUN 20	7.4.16	1-0	JAN 18
7.3.17	1-4	JUN 20			
7.3.18	1-4	JUN 20	7.5.1	1-0	JAN 18
7.3.19	1-4	JUN 20	7.5.2	1-5	JAN 21
7.3.20	1-4	JUN 20	7.5.3	1-0	JAN 18
7.3.21	1-4	JUN 20	7.5.4	1-0	JAN 18
7.3.22	1-4	JUN 20	7.5.5	1-0	JAN 18
7.3.23	1-4	JUN 20	7.5.6	1-0	JAN 18
7.3.24	1-4	JUN 20	7.5.7	1-0	JAN 18
7.3.25	1-4	JUN 20	7.5.8	1-0	JAN 18
7.3.26	1-4	JUN 20	7.5.9	1-5	JAN 21
7.3.27	1-4	JUN 20	7.5.10	1-0	JAN 18
7.3.28	1-5	JAN 21	7.5.11	1-4	JUN 20
7.3.29	1-4	JUN 20	7.5.12	1-0	JAN 18
7.3.30	1-4	JUN 20			
7.3.31	1-4	JUN 20	7.6.1	1-0	JAN 18
7.3.32	1-4	JUN 20	7.6.2	1-0	JAN 18
7.3.33	1-4	JUN 20	7.6.3	1-0	JAN 18
7.3.34	1-4	JUN 20	7.6.4	1-0	JAN 18
7.3.35	1-4	JUN 20	7.6.5	1-5	JAN 21
7.3.36	1-4	JUN 20	7.6.6	1-0	JAN 18
7.3.37	1-4	JUN 20	7.6.7	1-2	APR 19
7.3.38	1-4	JUN 20	7.6.8	1-0	JAN 18
7.3.39	1-4	JUN 20	7.6.9	1-0	JAN 18
7.3.40	1-4	JUN 20	7.6.10	1-2	APR 19
7.3.41	1-4	JUN 20	7.6.11	1-0	JAN 18
7.3.42	1-4	JUN 20	7.6.12	1-0	JAN 18
7.4.1	1-0	JAN 18	7.7.1	1-0	JAN 18
7.4.2	1-0	JAN 18	7.7.2	1-0	JAN 18
7.4.3	1-0	JAN 18	7.7.3	1-0	JAN 18
7.4.4	1-0	JAN 18	7.7.4	1-0	JAN 18

Pilot's Operating Handbook

Page No.	Edit./Rev. No.	Rev. Date	Page No.	Edit./Rev. No.	Rev. Date
■ 7.7.5	1-5	JAN 21	■ 7.9.14	1-5	JAN 21
7.7.6	1-0	JAN 18	7.9.15	1-3	FEB 20
7.7.7	1-0	JAN 18	7.9.16	1-3	FEB 20
■ 7.7.8	1-5	JAN 21	7.9.17	1-3	FEB 20
7.7.9	1-0	JAN 18	7.9.18	1-3	FEB 20
7.7.10	1-0	JAN 18	7.9.19	1-3	FEB 20
			7.9.20	1-3	FEB 20
7.8.1	1-0	JAN 18	■ 7.9.21	1-5	JAN 21
7.8.2	1-0	JAN 18	7.9.22	1-3	FEB 20
7.8.3	1-0	JAN 18			
7.8.4	1-0	JAN 18	■ 7.10.1	1-5	JAN 21
7.8.5	1-0	JAN 18	7.10.2	1-5	JAN 21
7.8.6	1-0	JAN 18	7.10.3	1-5	JAN 21
7.8.7	1-0	JAN 18	7.10.4	1-5	JAN 21
7.8.8	1-4	JUN 20	7.10.5	1-5	JAN 21
7.8.9	1-0	JAN 18	7.10.6	1-5	JAN 21
7.8.10	1-4	JUN 20	7.10.7	1-5	JAN 21
7.8.11	1-4	JUN 20	7.10.8	1-5	JAN 21
7.8.12	1-4	JUN 20	7.10.9	1-5	JAN 21
7.8.13	1-4	JUN 20	■ 7.10.10	1-5	JAN 21
7.8.14	1-4	JUN 20			
7.8.15	1-4	JUN 20	■ 7.11.1	1-5	JAN 21
7.8.16	1-4	JUN 20	7.11.2	1-5	JAN 21
■ 7.8.17	1-5	JAN 21	7.11.3	1-0	JAN 18
7.8.18	1-4	JUN 20	■ 7.11.4	1-5	JAN 21
7.8.19	1-4	JUN 20	7.11.5	1-0	JAN 18
7.8.20	1-4	JUN 20	7.11.6	1-0	JAN 18
7.8.21	1-4	JUN 20			
7.8.22	1-4	JUN 20	7.12.1	1-0	JAN 18
			7.12.2	1-0	JAN 18
■ 7.9.1	1-5	JAN 21	7.12.3	1-0	JAN 18
7.9.2	1-5	JAN 21	7.12.4	1-0	JAN 18
7.9.3	1-5	JAN 21			
7.9.4	1-5	JAN 21	7.13.1	1-0	JAN 18
7.9.5	1-5	JAN 21	7.13.2	1-3	FEB 20
7.9.6	1-5	JAN 21	7.13.3	1-2	APR 19
7.9.7	1-5	JAN 21	7.13.4	1-0	JAN 18
7.9.8	1-5	JAN 21			
7.9.9	1-5	JAN 21	7.14.1	1-0	JAN 18
7.9.10	1-5	JAN 21	7.14.2	1-0	JAN 18
7.9.11	1-5	JAN 21	7.14.3	1-2	APR 19
7.9.12	1-5	JAN 21	7.14.4	1-0	JAN 18
7.9.13	1-5	JAN 21	7.14.5	1-0	JAN 18

Page No.	Edit./Rev. No.	Rev. Date	Page No.	Edit./Rev. No.	Rev. Date
7.14.6	1-0	JAN 18	8.7.7	1-0	JAN 18
7.14.7	1-0	JAN 18	8.7.8	1-5	JAN 21
7.14.8	1-4	JUN 20	8.7.9	1-5	JAN 21
7.14.9	1-4	JUN 20	8.7.10	1-5	JAN 21
7.14.10	1-3	FEB 20	8.7.11	1-0	JAN 18
7.14.11	1-3	FEB 20	8.7.12	1-0	JAN 18
7.14.12	1-3	FEB 20	8.7.13	1-0	JAN 18
7.14.13	1-5	JAN 21	8.7.14	1-0	JAN 18
7.14.14	1-5	JAN 21			
7.14.15	1-0	JAN 18	8.8.1	1-0	JAN 18
7.14.16	1-0	JAN 18	8.8.2	1-0	JAN 18
8.0.1	1-0	JAN 18	8.9.1	1-5	JAN 21
8.0.2	1-0	JAN 18	8.9.2	1-4	JUN 20
			8.9.3	1-4	JUN 20
8.1.1	1-0	JAN 18	8.9.4	1-4	JUN 20
8.1.2	1-0	JAN 18	8.9.5	1-4	JUN 20
			8.9.6	1-4	JUN 20
8.2.1	1-0	JAN 18	8.9.7	1-4	JUN 20
8.2.2	1-0	JAN 18	8.9.8	1-5	JAN 21
			8.9.9	1-4	JUN 20
8.3.1	1-0	JAN 18	8.9.10	1-4	JUN 20
8.3.2	1-0	JAN 18	8.9.11	1-4	JUN 20
			8.9.12	1-4	JUN 20
8.4.1	1-0	JAN 18	8.9.13	1-4	JUN 20
8.4.2	1-0	JAN 18	8.9.14	1-4	JUN 20
8.5.1	1-0	JAN 18	8.10.1	1-0	JAN 18
8.5.2	1-0	JAN 18	8.10.2	1-0	JAN 18
8.6.1	1-0	JAN 18	Section 9		
8.6.2	1-0	JAN 18	(See log of supplements)		
8.6.3	1-0	JAN 18			
8.6.4	1-0	JAN 18			
8.6.5	1-0	JAN 18			
8.6.6	1-0	JAN 18			
8.7.1	1-0	JAN 18			
8.7.2	1-0	JAN 18			
8.7.3	1-0	JAN 18			
8.7.4	1-0	JAN 18			
8.7.5	1-0	JAN 18			
8.7.6	1-0	JAN 18			

Section 1**General**

Table of contents

1.1	-	General	1.1.1
1.2	-	Three view drawing	1.2.1
1.3	-	Descriptive data	1.3.1
		Engine	1.3.1
		Propeller	1.3.1
		Fuel	1.3.2
		Engine oil	1.3.3
		Maximum certificated weights	1.3.3
		Standard airplane weights	1.3.3
		Cabin and entry dimensions	1.3.4
		Specific loadings	1.3.4
1.4	-	Abbreviations and terminology	1.4.1
		Meteorological terminology	1.4.1
		General airspeed terminology and symbols	1.4.1
		Power terminology	1.4.2
		Airplane performance and flight planning terminology	1.4.3
		Weight and balance terminology	1.4.3
		General abbreviations	1.4.4
		Radio-navigation abbreviations	1.4.8
1.5	-	Conversion factors	1.5.1
1.6	-	Pressure and standard atmosphere	1.6.1
		Standard atmosphere	1.6.1
		Pressure conversion table	1.6.2

Intentionally left blank

1.1 - General

This POH contains 9 sections and includes the material required by FAR Part 23 to be furnished to the pilot for operation of the TBM airplane. It also contains supplemental data supplied by the manufacturer, in accordance with GAMA standard.

Section 1 provides basic data and information of general interest. It also contains definitions or explanations of abbreviations and terminology commonly used.

Whenever this POH refers to the GARMIN integrated Flight Deck Pilot's Guide, it states the one described in section 2.1.

Whenever this POH refers to the MD302 Pilot's Guide, it states the one described in section 2.1.

The general information for complex optional systems are given in section 9, Supplements of the POH.

The installed ADS-B OUT system has been shown to meet the equipment requirements of 14 CFR 91.227.

The installed transponder system is able to respond to interrogations in Modes A, C and S and is fully compliant with the requirements of CS ACNS.D.ELS/EHS (Mode S Elementary/Enhanced Surveillance).

The installed ADS-B OUT system is fully compliant with the requirements of CS ACNS.D.ADSB (1090 MHz Extended Squitter ADS-B OUT).

Part 135 operations

For 14 CFR 135 operations, TBM airplane alternative source of electric power is able to supply 150 percent of the electrical loads of all required instruments and equipment for safe emergency operation of the aircraft for at least 1 hour.

Electrical load shedding procedure provided in section 3 of this POH must be followed in order to meet the requirements of that paragraph under 14 CFR 135.163(f)(2).

Intentionally left blank

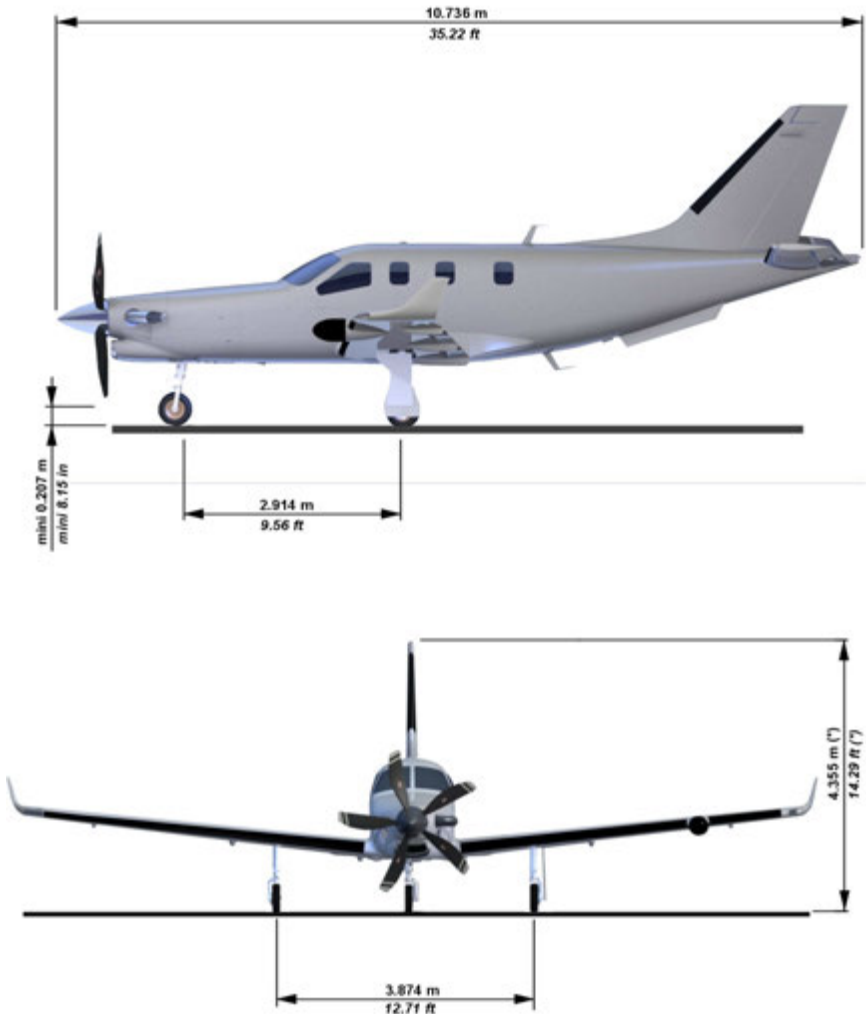
1.2 - Three view drawing

* Airplane on level field with fully extended FWD shock-absorber

Figure 1.2.1 (1/2) - Three view drawing

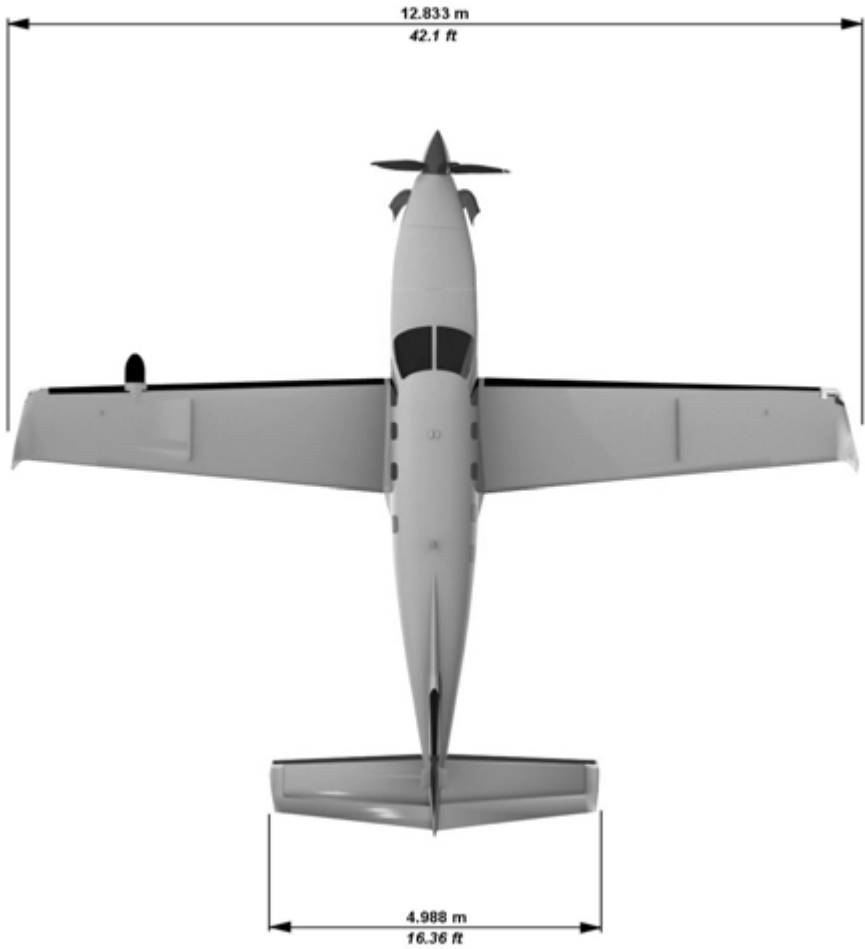

Figure 1.2.1 (2/2) - Three view drawing

1.3 - Descriptive data

Engine

Number of engines : 1

Engine manufacturer : PRATT & WHITNEY CANADA

Engine model number : PT6A - 66D

Engine type : Free turbine, reverse flow and 2 turbine sections

Compressor type : 4 axial stages, 1 centrifugal stage

Combustion chamber type : annular

Turbine type : 1 gas generator turbine stage, 2 power turbines stages

Horsepower rating and propeller speed : 850 SHP at 2000 RPM

Propeller

Number of propellers : 1

Propeller manufacturer : HARTZELL

Propeller model number : HC-E5N-3C / NC8834K

Number of blades : 5

Propeller diameter :

Minimum : 90 in (2.286 m)

Maximum : 91 in (2.311 m)

Propeller type : Adjustable constant speed, with feathering and hydraulic control reverse

Propeller blade setting at station 30 in :

Low pitch : 19.5°

Feathering : 85°

Maximum reverse : - 9°

Propeller governor : 8210.007 WOODWARD

Fuel

Total capacity : 301 USG (1140 litres)

Total capacity each tank : 150.5 USG (570 litres)

Total usable : 292 USG (1106 litres)

▲ CAUTION ▲

The fuel used must contain an anti-ice additive, in accordance with specification MIL-I-27686 or MIL-I-85470. Additive concentrations (EGME or DIEGME) shall be comprised between a minimum of 0.06 % and a maximum of 0.15 % by volume. Refer to section 8 Handling, servicing and maintenance for additional information.



▲ CAUTION ▲

The use of aviation gasoline (AVGAS) must be restricted to emergency purposes only. AVGAS shall not be used for more than 150 cumulative hours during any period between engine overhaul periods.



● NOTE ●

Use of AVGAS to be recorded in engine module logbook.



US specification (US)	French specification (FR)	English specification (UK)	NATO code
ASTM-D1655 JET A ASTM-D1655 JET A1 ASTM-D1655 JET B	AIR 3405C Grade F35	DERD 2494 Issue 9	F35 without additive
MIL-DTL-5624 Grade JP-4	AIR 3407B	DERD 2454 Issue 4 Amdt 1	F40 with additive
MIL-DTL-5624 Grade JP-5	AIR 3404C Grade F44	DERD 2452 Issue 2 Amdt 1	F44 with additive when utilization
MIL-DTL-83133 Grade JP-8	AIR 3405C Grade F34	DERD 2453 Issue 4 Amdt 1	F34 with additive S748
	AIR 3404C Grade F43	DERD 2498 Issue 7	F43 without additive

Figure 1.3.1 - Recommended fuel types
Reference : Service Bulletin P & W C. No. 14004

Engine oil

System total capacity : 12.7 Quarts (12 litres) (oil cooler included)

Usable capacity : 6 Quarts (5.7 litres)

Maximum oil consumption in 10 hour period : 0.14 qt/hr (0.13 l/hr)
[0.3 lb/hr (0.136 cc/hr)]

Specification

Nominal viscosity	Specification	NATO code
5cSt	MIL-PRF-23699G	O-156 (STD) O-154 (HTS)

Figure 1.3.2 - Recommended engine oil types

Reference : Service Bulletin P & W C. No. 14001 at the latest revision

Maximum certificated weights

Ramp : 7430 lbs (3370 kg)

Takeoff : 7394 lbs (3354 kg)

Landing : 7024 lbs (3186 kg)

Baggage weight

- refer to section 2, paragraph 2.5 for weight and C.G. limits
- refer to section 6 for cargo loading instructions

Standard airplane weights

Standard empty weight : 4583 lbs (2079 kg)

Maximum useful load : 2811 lbs (1275 kg)

Cabin and entry dimensions

Maximum cabin width : 3 ft 11.64 in (1.21 m)

Maximum cabin length : 13 ft 3.45 in (4.05 m)

Maximum cabin height : 4 ft (1.22 m)

Number of cabin entries : 1 (standard) + 1 pilot door (if installed)

Entry width (standard) : 3 ft 6.52 in (1.08 m)

Entry height (standard) : 3 ft 10.85 in (1.19 m)

Pilot entry mean width : 2 ft 3.6 in (0.70 m)

Pilot entry mean height : 3 ft 2.16 in (0.97 m)

Specific loadings

Wing loading : 38.16 lbs / sq.ft (186.3 kg / m²)

Power loading : 8.7 lbs / SHP (3.95 kg / SHP)

1.4 - Abbreviations and terminology

Meteorological terminology

ISA	:	International standard atmosphere
OAT	:	Outside air temperature
SAT	:	Static air temperature
QFE	:	Atmospheric pressure at the airport reference point.
QNH	:	Atmospheric pressure at sea level, at airplane position.

● NOTE ●

On the ground, the altimeter will indicate zero if it is set to QFE. It will indicate airport altitude if it is set to QNH.

●

Standard Temperature :

Is 15°C (59°F) at sea level pressure altitude and decreases by 2°C (3.6°F) for each 1000 ft of altitude.

Pressure altitude :

Is the altitude read from an altimeter when the altimeter's barometric scale has been set to 29.92 inches of mercury (1013.2 hPa).

General airspeed terminology and symbols

KCAS	:	Knots Calibrated Airspeed is the indicated airspeed expressed in knots corrected for position and instrument error. Knots calibrated airspeed is equal to KTAS in standard atmosphere at sea level.
KIAS	:	Knots Indicated Airspeed is the speed shown on the airspeed indicator and expressed in knots.
KTAS	:	Knots True Airspeed is the airspeed expressed in knots relative to undisturbed air which is KCAS corrected for altitude and temperature.
V_A	:	Maneuvering Speed is the maximum speed at which full or abrupt control movements may be used.
V_{FE}	:	Maximum Flap Extended Speed is the highest speed permissible with wing flaps in a prescribed extended position.
V_{LE}	:	Maximum Landing Gear Extended Speed is the maximum speed at which an airplane can be safely flown with the landing gear extended.

- V_{LO}** : Maximum Landing Gear Operating Speed is the maximum speed at which the landing gear can be safely extended or retracted.
- V_{MO}** : Maximum Operating Speed is the speed limit that may not be deliberately exceeded in normal flight operations.
- V_R** : Rotation Speed is the speed at which rotation is initiated during takeoff to achieve takeoff safety speed at screen height.
- V_{SO}** : Stalling Speed or the minimum steady flight speed at which the airplane is controllable in the landing configuration.
- V_{S1}** : Stalling Speed or the minimum steady flight speed obtained in a specific configuration.
- V_x** : Best Angle of Climb Speed is the airspeed which delivers the greatest gain of altitude in the shortest possible horizontal distance.
- V_Y** : Best Rate of Climb Speed is the airspeed which delivers the greatest gain in altitude in the shortest possible time.

Power terminology

Recovery altitude :

Maximum altitude at which it is possible, in standard temperature, to maintain a specified power.

Overheated start :

Engine start or attempt to start which causes the interturbine temperature to be higher than the maximum value permissible during start.

Flame out : Involuntary loss of the combustion chamber flame during operation.

GPU : Ground power unit.

Feathering : Action which reduces the drag of a propeller by positioning blades at the pitch angle allowing minimal drag.

Maximum Cruise Power :

Power developed corresponding to outside flight level and temperature conditions - refer to chapter 5 Performance.

Ng : Gas generator RPM.

Np : Propeller rotation speed.

Reverse : Drag produced when the propeller blade setting is negative.

RPM : Revolutions per minute.

SHP : Shaft Horsepower.

TRQ : Torque.

Airplane performance and flight planning terminology

Climb gradient :

Is the ratio of the change in height during a portion of climb, to the horizontal distance traversed in the same time interval.

Demonstrated crosswind velocity :

Is the velocity of the crosswind component for which adequate control of the airplane during takeoff and landing was actually demonstrated during certification tests. The value shown is not considered to be limiting.

g : Is acceleration due to gravity.

Usable fuel : Total fuel which can be effectively consumed by the engine.

Weight and balance terminology

Reference datum :

Datum perpendicular to the longitudinal airplane centerline from which all distances are measured for balance purpose.

Arm : Is the distance from the reference datum to the center of gravity (C.G.) of an item.

Moment : Is the product of the weight of an item multiplied by its arm.

Center of gravity (C.G.) :

Airplane balance point. Its distance from the reference datum is found by dividing the total moment by the total weight of the airplane.

C.G. limits : Center of Gravity Limits are the extreme center of gravity locations within which the airplane must be operated at a given weight.

Standard empty weight :

Weight of a standard airplane including unusable fuel and full operating fluids (oil and hydraulic fluids).

Basic empty weight :

Standard empty weight plus optional equipment.

Useful load : Is the difference between maximum ramp weight and the basic empty weight.

Maximum ramp weight :

Is the maximum weight approved for ground maneuver. It includes the weight of start, taxi and run up fuel.

Maximum takeoff weight :

Is the maximum weight approved at the beginning of the takeoff run.

Maximum landing weight :

Is the maximum weight approved for landing touchdown.

General abbreviations

A	: Ampere or Amber
ADC	: Air Data Computer
AGL	: Above ground level
AIL TRIM	: Aileron TRIM
ALT. SEL.	: Altitude selector
ALTI	: Altimeter
AMP	: Ampere
AoA	: Angle of Attack
AP	: Autopilot
ATIS	: Automatic Terminal Information Service
AUTO SEL	: Automatic selector
AUX BP	: Auxiliary boost pump
BAT	: Battery
BRT	: Brightness
CAS	: Crew Alerting System
°C	: Celsius degree
CONT.	: Control
DIEGME	: Diethylene glycol monomethyl ether
DISC	: Disconnect
DN	: Down
EDM	: Emergency Descent Mode
EGME	: Ethylene glycol monomethyl ether

Pilot's Operating Handbook

EIS	:	Engine Indication System
EMER	:	Emergency
ESHP	:	Estimated shaft horsepower
ESP	:	Electronic Stability Protection
ESS. BUS TIE	:	Essential BUS tie
EXT. LIGHTS	:	Exterior lightings
°F	:	Fahrenheit degree
FCU	:	Fuel control unit
FL	:	Flight level
FOB	:	Fuel On Board
FPL	:	Flight Plan
ft	:	Feet
ft/min	:	Feet per minute
G	:	Green
GIFD	:	Garmin Integrated Flight Deck
HI	:	High
HP	:	High pressure
hPa	:	Hectopascal
hr	:	Hour
HTR	:	Heater
HTRS	:	Heaters
IGNIT	:	Ignition
in	:	Inch / inches
INERT SEP	:	Inertial separator
INDIC	:	Indicator
in.Hg	:	Inch of mercury
INT. LIGHTS	:	Interior lightings
INSTR.	:	Instrument

ITT	: Interturbine temperature
kg	: Kilogram
kt	: Knot (1 nautical mile/hr - 1852 m/hr)
kW	: Kilowatt
l	: Litre
L or L.H.	: Left
l/h	: Litre / hour
lb or lbs	: Pound(s)
L / D	: Lift-to-drag
LDG	: Landing
LDG GR	: Landing gear
LDR	: Lightweight Data Recorder
LFE	: Landing Field Elevation
LRCR	: Long Range Cruise
LO	: Low
LP	: Low pressure
LRN	: Long range navigation
LTS TEST	: Lightings test
m	: Metre
m.a.c. or MAC	: Mean aerodynamic chord
MAIN GEN	: Main generation
MAN	: Manual
MAN OVRD	: Manual override
MAX RPM	: Maximum revolutions per minute
MDA	: Minimum Descent Altitude
MFD	: Multi-function Display
MIN	: Minimum
min	: Minute

Pilot's Operating Handbook

mm	:	Millimetre
MLW	:	Maximum Landing Weight
MRW	:	Maximum Ramp Weight
msg	:	Message
MTOW	:	Maximum Takeoff Weight
■ MXCL	:	Maximum Climb
MXCR	:	Maximum Cruise
MZFW	:	Maximum Zero Fuel Weight
NM	:	Nautical mile
NOCR	:	Normal cruise (recommended)
NORM	:	Normal
PFD	:	Primary Flight Display
PHF	:	Plan Horizontal Fixe (Horizontal stabilizer)
PRESS	:	Pressure
PROP	:	Propeller
psi	:	Pounds per square inch
■ PSIG	:	Pounds per Square Inch Gauge
qt	:	Quart (¼ USG)
QTY	:	Quantity
R or R.H.	:	Right
RUD	:	Rudder
■ s or sec	:	Second(s)
SEL	:	Selector
SIG	:	Signalization
SL	:	Sea level
S/N	:	Serial number
SPKR	:	Speaker
ST - BY	:	Stand-by

■ STALL HTR	: Stall warning heater
Std	: Standard
■ STPD	: Standard Temperature Pressure Dry
T°	: Temperature
TEMP	: Temperature
TO	: Takeoff
TURN COORD	: Turn coordinator
USG	: Gallon U.S
USP	: Under Speed Protection
V	: Volt or Voltage
WARN	: Warning
W / S	: Windshield

Radio-navigation abbreviations

ADF	: Automatic Direction Finder System
ADI	: Attitude Director Indicator
ADS-B	: Automatic Dependent Surveillance-Broadcast
AFCS	: Automated Flight Control System
AHRS	: Attitude and Heading Reference System
AIRAC	: Aeronautical Information Regulation And Control
ATC	: Air Traffic Control
Baro VNAV	: Barometric Vertical NAVigation
B RNAV	: Basic aRea NAVigation
CDI	: Course Deviation Indicator
COM	: Communications Transceivers
DME	: Distance Measuring Equipment
ELT	: Emergency Locator Transmitter
FDE	: Fault Detection and Exclusion
FMS	: Flight Management System

Pilot's Operating Handbook

GNSS	: Global Navigation Satellite System
GPS	: Global Positioning System
HF	: High Frequency
IFR	: Instrument Flight Rules
ILS	: Instrument Landing System
IMC	: Instrument Meteorological Conditions
L NAV	: Lateral NAVigation
LPV	: Localizer Precision Vertical
MKR	: Marker Radio Beacon
NAV	: Navigation Indicators or Receivers
P RNAV	: Precision aRea NAVigation
RAIM	: Receiver Autonomous Integrity and Monitoring
RF Leg	: Radius to Fix Leg
R NAV	: Area NAVigation
RNP	: Required Navigation Performance
SAM	: Standby Attitude Module
SBAS	: Satellite Based Augmentation System
STAR	: Standard Terminal Arrival Route
TAS	: Traffic Advisory System
TAWS	: Terrain Awareness Warning System
VFR	: Visual Flight Rules
VHF	: Very High Frequency
VMC	: Visual Meteorological Conditions
V NAV	: Vertical NAVigation
VOR	: VHF Omnidirectional Range
VOR / LOC	: VHF Omnidirectional Range LOCALizer
WAAS	: Wide Area Augmentation System
WFDE	: WAAS Fault Detection and Exclusion

- WGS** : World Geodetic System
- WXR** : Weather surveillance radar
- XPDR** : Transponder

1.5 - Conversion factors

Imperial and U.S units to metric units			Metric units to Imperial and U.S units		
Multiply	By	To obtain	Multiply	By	To obtain
feet	0.3048	metre	metre	3.2808	feet
inch	25.4	mm	mm	0.03937	Inch
Imp.Gal	4.546	litre	litre	0.220	Imp.Gal
USG	3.785	litre	litre	0.264	USG
lb	0.45359	kg	kg	2.2046	lb

Figure 1.5.1 - Imperial and U.S units to metric units

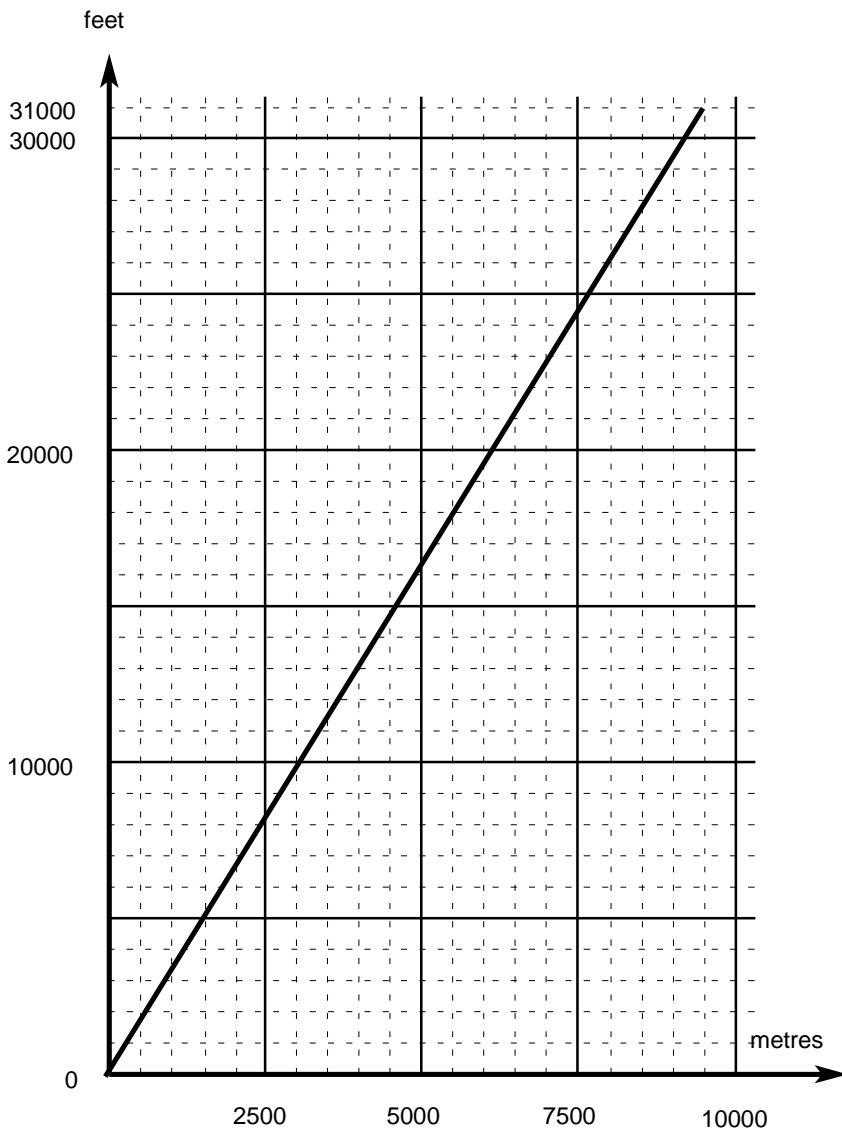

Figure 1.5.2 - Feet versus metres

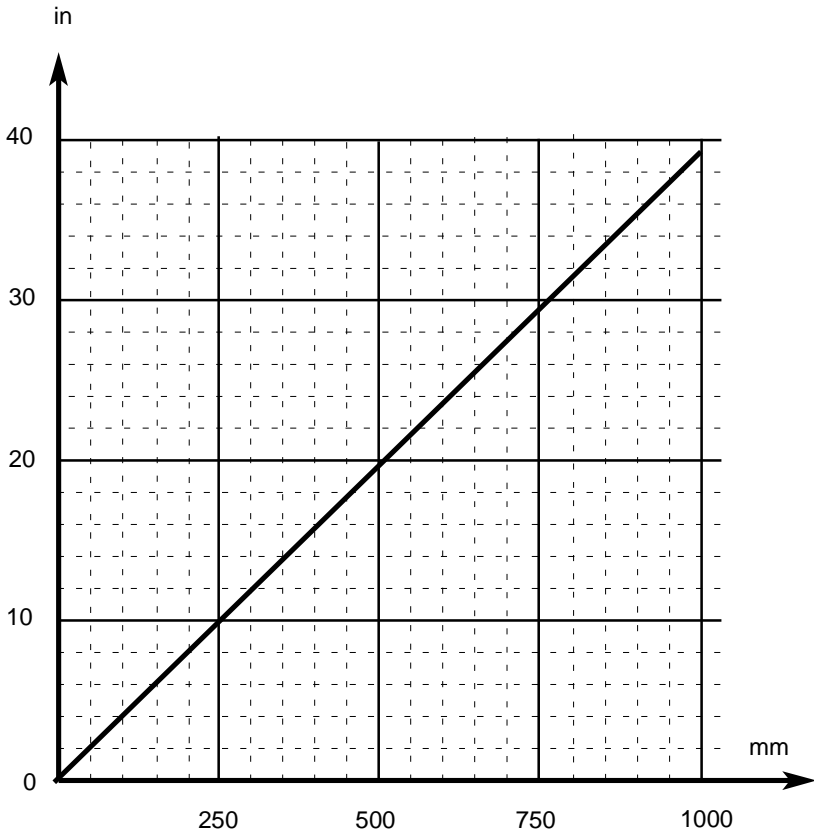

Figure 1.5.3 - Inches versus millimetres

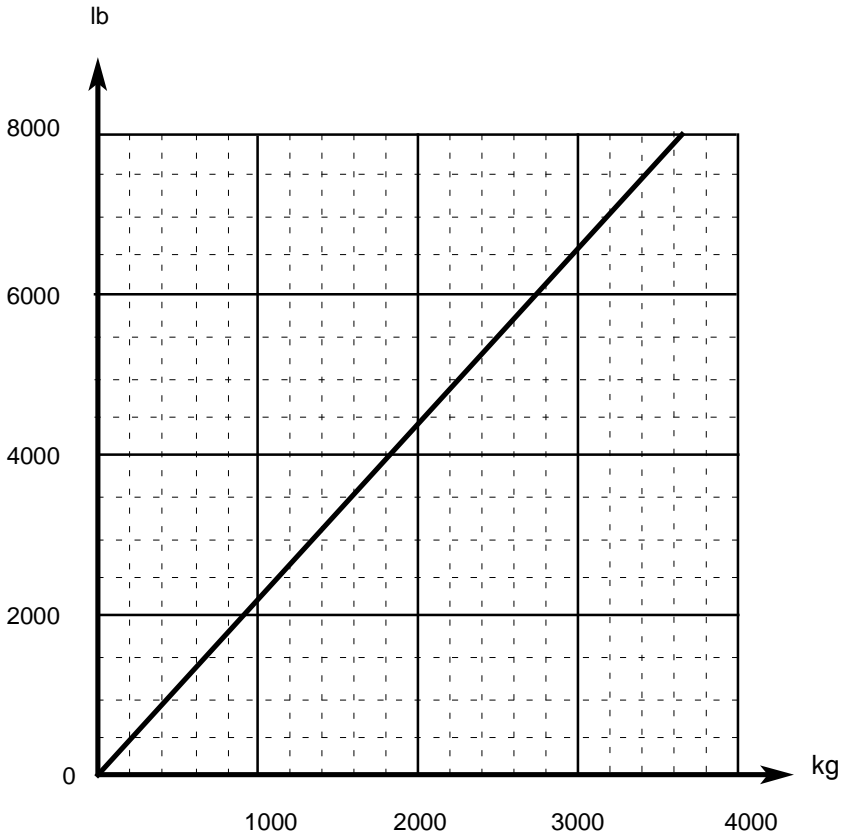

Figure 1.5.4 - Pounds versus kilograms

1.6 - Pressure and standard atmosphere

Standard atmosphere

Pressure altitude (ft)	Pressure (hPa)	°C	°F
0	1013.2	+ 15.0	+ 59.0
2000	942.1	+ 11.0	+ 51.8
4000	875.0	+ 7.0	+ 44.6
6000	811.9	+ 3.1	+ 37.6
8000	752.6	- 0.8	+ 30.5
10000	696.8	- 4.8	+ 23.4
12000	644.3	- 8.7	+ 16.2
14000	595.2	- 12.7	+ 9.2
16000	549.1	- 16.6	+ 2.2
18000	505.9	- 20.6	- 5.0
20000	465.6	- 24.6	- 12.4
22000	427.8	- 28.5	- 19.3
24000	392.6	- 32.5	- 26.5
26000	359.8	- 36.5	- 33.6
28000	329.3	- 40.4	- 40.7
30000	300.8	- 44.4	- 47.8
31000	287.4	- 46.4	- 51.6

Figure 1.6.1 - Standard atmosphere

Pressure conversion table

• NOTE •

The standard pressure of 1013.2 hPa is equal to 29.92 inches of mercury.

•

950 28.05	951 28.08	952 28.11	953 28.14	954 28.17	955 28.20	956 28.23	957 28.26	958 28.29	959 28.32
960 28.35	961 28.38	962 28.41	963 28.44	964 28.47	965 28.50	966 28.53	967 28.56	968 28.58	969 28.61
970 28.64	971 28.67	972 28.70	973 28.73	974 28.76	975 28.79	976 28.82	977 28.85	978 28.88	979 28.91
980 28.94	981 28.97	982 29.00	983 29.03	984 29.06	985 29.09	986 29.12	987 29.15	988 29.18	989 29.20
990 29.23	991 29.26	992 29.29	993 29.32	994 29.35	995 29.38	996 29.41	997 29.44	998 29.47	999 29.50
1000 29.53	1001 29.56	1002 29.59	1003 29.62	1004 29.65	1005 29.68	1006 29.71	1007 29.74	1008 29.77	1009 29.80
1010 29.83	1011 29.85	1012 29.88	1013 29.91	1014 29.94	1015 29.97	1016 30.00	1017 30.03	1018 30.06	1019 30.09
1020 30.12	1021 30.15	1022 30.18	1023 30.21	1024 30.24	1025 30.27	1026 30.30	1027 30.33	1028 30.36	1029 30.39
1030 30.42	1031 30.45	1032 30.47	1033 30.50	1034 30.53	1035 30.56	1036 30.59	1037 30.62	1038 30.65	1039 30.68
1040 30.71	1041 30.74	1042 30.77	1043 30.80	1044 30.83	1045 30.86	1046 30.89	1047 30.92	1048 30.95	1049 30.98

Figure 1.6.2 - Pressure conversion table

Section 2

Limitations

Table of contents

2.1	-	General	2.1.1
2.2	-	Airspeed limitations	2.2.1
2.3	-	Powerplant limitations	2.3.1
		Engine	2.3.1
		Oil	2.3.2
		Fuel	2.3.3
		Propeller	2.3.4
2.4	-	Starter operation limits	2.4.1
2.5	-	Weight and C.G. limits	2.5.1
		Weight limits	2.5.1
		C.G. limits	2.5.2
2.6	-	Operation limits	2.6.1
		Maneuver limits	2.6.1
		Temperature limits	2.6.1
		Flight load factor limits	2.6.1
		Generator limits	2.6.2
		GFC 700 autopilot limits	2.6.2
		GNSS (GPS/SBAS) navigation equipment approvals	2.6.2
		GNSS (GPS/SBAS) navigation system limitations	2.6.7
		Icing conditions	2.6.10
		Severe icing conditions	2.6.10
		Flap operating envelope	2.6.11
		Reverse utilization	2.6.11
		Weather radar GWX 70	2.6.11
		Equipment required depending on type of operation	2.6.12
		Altitude operating limits	2.6.17
		In-flight breaker use limits	2.6.17
		Enhanced mode S	2.6.18
		Chartview system operating limitations	2.6.19

2.7	-	Miscellaneous limits	2.7.1
		Seating limits C.G.	2.7.1
		Baggage limits	2.7.1
		Minimum crew	2.7.1
		Maximum occupancy	2.7.1
		Use of doors	2.7.1
		Chemical toilet cabinet, if installed	2.7.1
		Cargo net installation limits	2.7.2
		Weather radar limitation	2.7.2
2.8	-	Markings	2.8.1
		Airspeed Indicator on PFD(s) and on Standby airspeed indicator	2.8.1
		Pressurization	2.8.1
		Engine instruments	2.8.2
2.9	-	Placards	2.9.1

2.1 - General

TBM 930 is the trade name of the TBM 700 N version airplane (TBM 700 type), which is certified in the normal category.

This airplane must be flown in compliance with the limits specified by placards or markings and with those given in this section and throughout the POH.

>> *Up to S/N 1215*

The GARMIN G3000 Integrated Flight Deck Pilot's Guide, No. 190-02046-02, or any later version as applicable, must be readily available to the pilot and permanently kept in the airplane with the POH.

>> *From S/N 1216*

The GARMIN G3000 Integrated Flight Deck Pilot's Guide, No. 190-02420-00, or any later version as applicable, must be readily available to the pilot and permanently kept in the airplane with the POH.

>> *All*

The Pilot's Guide for MD302 Standby Attitude Module P/N 9017846-00 or any later version as applicable, must be permanently kept in the airplane with the POH.

Departure into IMC is not authorized if the MD302 battery fails its initial capacity check with associated message :

"WARNING
INTERNAL BATTERY MAY PROVIDE LESS THAN 60 MINUTES OF
OPERATIONS"

or if there is a red "X" over the battery symbol at MD302 initialization.

This section of the airplane POH presents the various operating limitations, the significance of such limitations, instrument markings, color coding, and basic placards necessary for the safe operation of the airplane, its powerplant and installed equipment.

The limitations included in this section have been approved by the Federal Aviation Administration in accordance with 14 CFR section 21.29.

The limitations for some optional systems are given in section 9, Supplements of the POH.

TBM 700 airplane is certified under EASA.A.010 and FAA N° A60EU Type Certificates.

Intentionally left blank

2.2 - Airspeed limitations

Airspeed limitations and their operational significance are shown in figure 2.2.1.

	Speed	KCAS	KIAS	Remarks
V _{MO}	Maximum operating speed	271	266	Do not intentionally exceed this speed in normal flight category
V _A	Maneuvering speed	160	158	Do not make abrupt or full control movements above this speed
V _{FE}	Maximum flaps extended speed : landing configuration takeoff configuration	120 180	122 178	Do not exceed these speeds depending on flaps position
V _{LO}	Maximum landing gear operating speed : extension retraction emergency extension	180 151 151	178 150 150	Do not extend or retract landing gear above this speed
V _{LE}	Maximum landing gear extended speed	180	178	Do not exceed this speed with landing gear extended

Figure 2.2.1 - Airspeed limitations

Intentionally left blank

2.3 - Powerplant limitations

Engine

Number of engines : 1

Engine manufacturer : PRATT & WHITNEY CANADA

Engine model number : PT6A - 66D

Maximum power :

100 % at Np = 2000 RPM

Ng limitation :

104.1 %

Np limitation :

2000 RPM \pm 40 RPM

ITT limitations :

- Takeoff : 850°C
- Maximum climb/cruise : 840°C
- During start :
 - < 840°C, no duration limitation
 - < 870°C for 20 seconds max.
 - < 1000°C for 5 seconds max.

▲ **CAUTION** ▲

When normally operating, refer to chapter 5.8 Engine operation tables.



Oil

▲ CAUTION ▲

Do not mix different viscosities or specifications of oil as their different chemical structure can make them incompatible.



Maximum oil temperature : 104 °C

Oil pressure :

- Minimum : 60 psi
- Maximum : 135 psi, a transient oil pressure up to 170 psi is acceptable for maximum 20 seconds

Normal oil pressure is 105 to 135 psi. Oil pressures under 105 psi are undesirable. Under emergency conditions, to complete a flight, a lower oil pressure of 60 psi is permitted at reduced power level not exceeding 80% torque. Oil pressures below 60 psi are unsafe and require that either the engine be shut down or a landing be made as soon as possible using the minimum power required to sustain flight.

Oil capacity :

- System total capacity : 12.7 Quarts (12 litres), oil cooler included
- Usable capacity : 6 Quarts (5.7 litres)

Fuel

Fuel limitations :

- 2 tanks : 150.5 USG (570 litres) each
- Total fuel : 301 USG (1140 litres)
- Usable fuel : 292 USG (1106 litres)
- Unusable fuel : 9 USG (34 litres)
- Maximum fuel imbalance : 15 USG (57 litres)

• NOTE •

The quantity of usable fuel can be safely utilized during all normal airplane maneuvers.

•

▲ CAUTION ▲

The fuel used must contain an anti-ice additive, in accordance with specification MIL-I-27686 or MIL-I-85470. Additive concentrations (EGME or DIEGME) shall be between a minimum of 0.06 % and a maximum of 0.15 % by volume. Refer to section 8 Handling, servicing and maintenance for additional information.

▲

▲ CAUTION ▲

The use of aviation gasoline (AVGAS) must be restricted to emergency purposes only. AVGAS shall not be used for more than 150 cumulative hours during any period between engine overhaul periods.

▲

• NOTE •

Use of AVGAS to be recorded in engine module logbook.

•

▲ CAUTION ▲

Maximum sideslip duration is 30 seconds.

▲

US specification (US)	French specification (FR)	English specification (UK)	NATO code
ASTM-D1655 JET A ASTM-D1655 JET A1 ASTM-D1655 JET B	AIR 3405C Grade F35	DERD 2494 Issue 9	F35 without additive
MIL-DTL-5624 Grade JP-4	AIR 3407B	DERD 2454 Issue 4 Amdt 1	F40 with additive
MIL-DTL-5624 Grade JP-5	AIR 3404C Grade F44	DERD 2452 Issue 2 Amdt 1	F44 with additive when utilization
MIL-DTL-83133 Grade JP-8	AIR 3405C Grade F34	DERD 2453 Issue 4 Amdt 1	F34 with additive S748
	AIR 3404C Grade F43	DERD 2498 Issue 7	F43 without additive

Figure 2.3.1 - Recommended fuel types
 Reference : Service Bulletin P & W C. No. 14004

Propeller

Number of propellers : 1

Propeller manufacturer : HARTZELL

Propeller model number : HC-E5N-3C / NC8834K

Propeller diameter :

- Minimum : 90 in (2.286 m)
- Maximum : 91 in (2.311 m)

Propeller blade setting at station 30 in :

- Low pitch : 19.5°
- Feathering : 85°
- Maximum reverse : - 9°

2.4 - Starter operation limits

Starter operation sequence is limited as follows :

if Ng < 30 % 30 seconds

if Ng > 30 % 60 seconds

Should several sequences be necessary, respect following spacing :

1st sequence

wait 1 minute

2nd sequence

wait 5 minutes

3rd sequence

wait 30 minutes

4th sequence

Intentionally left blank

2.5 - Weight and C.G. limits

Weight limits

Maximum ramp weight (MRW) : 7430 lbs (3370 kg)

Maximum takeoff weight (MTOW) : 7394 lbs (3354 kg)

Maximum landing weight (MLW) : 7024 lbs (3186 kg)

Maximum zero fuel weight (MZFW) : 6032 lbs (2736 kg)

Maximum baggage weight :

- in FWD compartment (non pressurized) : 110 lbs (50 kg)

>> *With 6-seat accommodation*

- in rear part of pressurized cabin : 220 lbs (100 kg)

>> *With 4-seat accommodation*

- in rear part of pressurized cabin : 396 lbs (180 kg), with small or large net, see sketch below

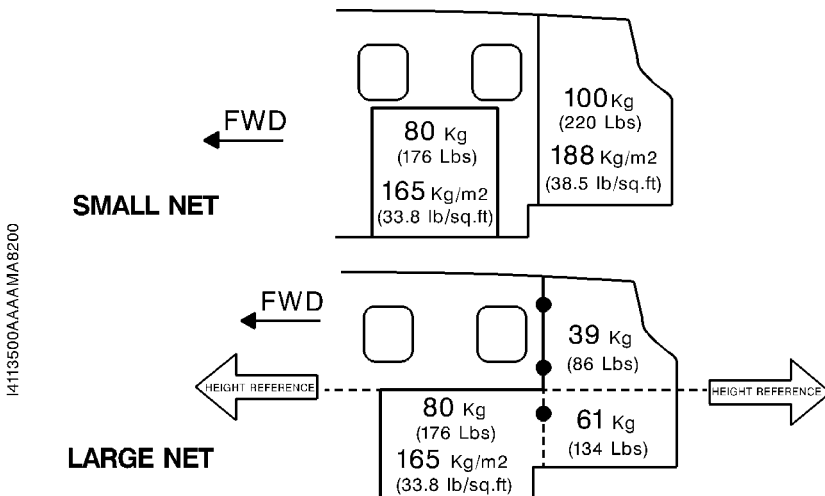

Figure 2.5.1 - Baggage limits

C.G. limits

Center of gravity range with landing gear down and flaps up, attitude 0° :

Forward limits :

181.3 in (4.604 m) aft of datum at 4409 lbs (2000 kg) or less (14 % of m.a.c)

183.6 in (4.664 m) aft of datum at 6250 lbs (2835 kg) (18 % of m.a.c)

185.3 in (4.707 m) aft of datum at 6579 lbs (2984 kg) (20.85 % of m.a.c)

187 in (4.752 m) aft of datum at all weights above 7024 lbs (3186 kg) (23.8 % of m.a.c)

Aft limits :

193.65 in (4.921 m) aft of datum at 7394 lbs (3354 kg) (35 % of m.a.c)

194 in (4.928 m) aft of datum at 6986 lbs (3169 kg) (35.5 % of m.a.c)

Reference datum : 118.1 in (3 m) in front of the firewall front face.

Straight line variation between points.

Leveling point : Cabin floor rails.

● NOTE ●

It is the responsibility of the pilot to insure that the airplane is properly loaded.
See section 6 Weight and balance for proper loading instructions.

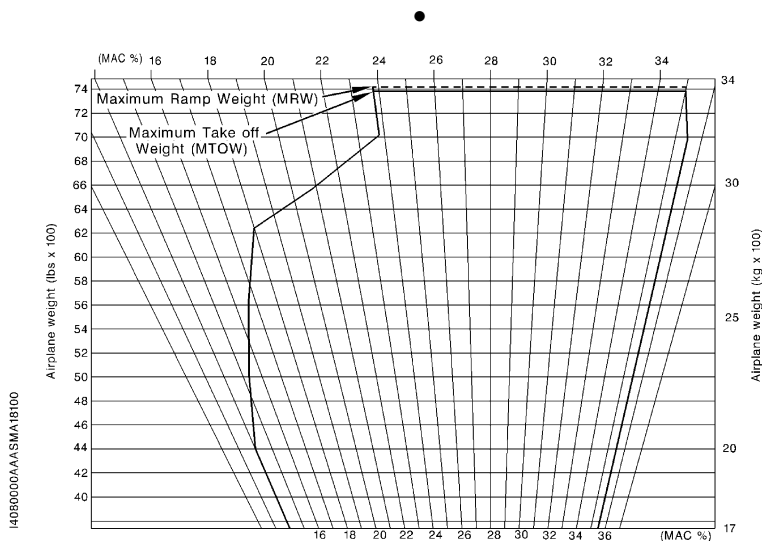

Figure 2.5.2 - C.G. limits

2.6 - Operation limits

Maneuver limits

This airplane is certified in the normal category.

The normal category is applicable to airplanes intended for non-aerobatic operations.

Non-aerobatic operations include any maneuvers incidental to normal flying, stalls (except whip stalls), lazy eights, chandelles, and steep turns in which the angle of bank is no more than 60°.

▲ WARNING ▲

Aerobatic maneuvers, including spins, are not approved.



Temperature limits

Minimum temperature at start and takeoff : - 40°C (- 40°F)

Maximum temperature at start and takeoff :

ISA + 37°C (+ 67°F) from 0 to 8000 ft pressure altitude

Maximum temperature in flight :

ISA + 37°C (+ 67°F) from 0 to 8000 ft pressure altitude

ISA + 30°C (+ 54°F) above 8000 ft pressure altitude

Flight load factor limits

Flaps up

Weight below 6579 lbs (2984 kg) : - 1.5 < n < + 3.8 g

Weight above 6579 lbs (2984 kg) : - 1.5 < n < + 3.5 g

Flaps down

- 0 < n < + 2.0 g

▲ CAUTION ▲

Intentional negative load factors prohibited.



Generator limits

Generator load must be below 200 A when the airplane is on the ground.

GFC 700 autopilot limits

- During autopilot operation, a pilot with seat belt fastened must be seated at the left or right position.
- The autopilot and yaw damper must be OFF during takeoff and landing.
- Do not engage autopilot below 1000 ft (300 m) AGL in cruise or climb.
- Do not use autopilot in approach below 200 ft (60 m) AGL.
- Do not use autopilot for airspeeds below 85 KIAS.

• NOTE •

Do not use the autopilot in descent below 2000 ft (600 m) AGL with a vertical speed in excess of 2000 ft/min.



GNSS (GPS/SBAS) navigation equipment approvals

The GARMIN GNSS navigation system installed in this airplane :

- is a GPS system with a Satellite Based Augmentation System (SBAS) comprised of :

>> *Up to S/N 1215*

- two TSO-C145a (or later) Class 3 approved GARMIN GIAs,
- TSO-C146c Class 3 approved GARMIN GDUs Display Units,
- GARMIN GA36 and GA37 antennas,
- GPS software version 5.0 or later approved version.

>> *From S/N 1216*

- two TSO-C145d Class 3 approved GARMIN GIAs,
- TSO-C146d Class 3 approved GARMIN GDUs Display Units,
- GARMIN GA36 and GA37 antennas,
- GPS software version 7.0 or later approved version.

■ >> All

- is installed in this airplane in accordance with AC 20-138A.
- is, as installed in this airplane, approved for navigation using GPS and GPS/SBAS (within the coverage of a SBAS complying with ICAO Annex 10) for IFR enroute, terminal area, and RNP APCH operations (to LNAV, LNAV/VNAV and LPV minima).
- is, as installed in this airplane, complying with the equipment, performance, and functional requirements to conduct RNAV and RNP operations in accordance with the applicable requirements of the reference documents listed in the following table.

● NOTE ●

Depending on the area of navigation, an operational approval may be required to use the navigation performance that are detailed in the table hereafter. The pilot is responsible to ensure compliance with current operational requirements.

●

This table is accurate at the time it was published.

Phase of flight	Approved PBN Capability	Operational limitations	Reference Documents	ICAO Flight Plan Code		Notes
				Item 10a Code	Item 18 PBN/	
En-route, Oceanic and Remote continental (Class II Navigation)	RNAV 10 RNP 10	GNSS FDE availability must be verified prior to flight. Maximum predicted FDE unavailability is 34 minutes. ¹ Two GNSS systems required to be operational. ²	FAA AC 90-105A	R	A1	Additional communication and surveillance equipment may be required to obtain operational approval to utilize RNP 10 / RNAV 10 performance.
En-route continental, Arrival	RNAV 5 (formerly designated as B-RNAV)	One GNSS system required to be operational.	JAA AMJ 20X2	R	B2	

Phase of flight	Approved PBN Capability	Operational limitations	Reference Documents	ICAO Flight Plan Code		Notes
				Item 10a Code	Item 18 PBN/	
En-route, Oceanic and Remote continental (Class II Navigation)	RNP 4	GNSS FDE availability must be verified prior to flight. Maximum predicted FDE unavailability is 25 minutes. ¹ Two GNSS systems required to be operational. ²	FAA AC 90-105A	R	L1	Additional communication and surveillance equipment may be required to obtain operational approval to utilize RNP 4 performance.
Departure En-route continental, Arrival	RNAV 2 / RNAV 1	One GNSS system required to be operational,	JAA TGL-10 FAA AC 90-105A	R	C2 / D2	
Domestic, Offshore, Oceanic and Remote continental	RNP 2	GNSS FDE availability must be verified prior to oceanic or remote continental flight. Maximum predicted FDE unavailability is 5 minutes. Two GNSS systems required to be operational. ² Only one operational GNSS system required for domestic and offshore operations areas.	FAA AC 90-105A	R	-	Additional communication and surveillance equipment may be required to obtain operational approval to utilize RNP 2 performance.
Departure, Arrival,	RNP 1 (with and without RF legs)	At a minimum, the flight director must be displayed and utilized when conducting procedures containing RF legs.	FAA AC 90-105A	R	O2	Includes RNP terminal departure and arrival procedures. This includes procedures with Radius-to-Fix legs (RF legs).

Phase of flight	Approved PBN Capability	Operational limitations	Reference Documents	ICAO Flight Plan Code		Notes
				Item 10a Code	Item 18 PBN/	
Approach	RNP APCH LNAV minima <i>(with and without RF legs)</i>	At a minimum, the flight director must be displayed and utilized when conducting procedures containing RF legs.	EASA AMC 20-27 FAA AC 90-105A	R	S1	Includes non-precision approaches based on conventional navigation aids with "or GPS" in the title and area navigation approaches titled "GPS", "RNAV (GPS)", and "RNAV (GNSS)". This includes procedures with RF legs. RF legs may be used in the initial and intermediate legs of the approach procedure or the final leg of the missed approach procedure only.

Phase of flight	Approved PBN Capability	Operational limitations	Reference Documents	ICAO Flight Plan Code		Notes
				Item 10a Code	Item 18 PBN/	
Approach	RNP APCH LNAV/VNAV minima <i>(with and without RF legs)</i>	At a minimum, the flight director must be displayed and utilized when conducting procedures containing RF legs. QNH shall be available at the destination airport when conducting a Baro-VNAV approach. Use of remote altimeter setting source is not allowed to conduct a Baro-VNAV approach. The two primary altimeters must be operational when flying a RNP APCH LNAV/VNAV with Baro-VNAV guidance	EASA AMC 20-27 FAA AC 90-105A	R	S2	Includes area navigation approaches titled "RNAV (GPS)" and "RNAV (GNSS)" This includes procedures with RF legs. Vertical guidance is based on GPS/SBAS and/or Baro-VNAV. RF legs may be used in the initial and intermediate legs of the approach procedure or the final leg of the missed approach procedure only.
Approach	RNP APCH LPV minima <i>(with and without RF legs)</i>	At a minimum, the flight director must be displayed and utilized when conducting procedures containing RF legs.	EASA AMC 20-28	B		RF legs may be used in the initial and intermediate legs of the approach procedure or the final leg of the missed approach procedure only.

¹ and ², see Note 1 and Note 2 hereafter

Table 2.6.1 - GNSS operational requirements

- Note 1 FDE/RAIM availability worldwide can be determined using the WFDE Prediction program, part number 006-A0154-01 or later approved version with GARMIN GA36 and GA37 antennas selected, or :
- Within the United States, using the FAA's en-route and terminal RAIM prediction website : www.raimprediction.net, or by contacting a Flight Service Station.
 - Within Europe, using Europe's AUGUR GPS RAIM Prediction Tool at <http://augur.ecacnav.com/augur/app/home>.
- Note 2 A **BOTH ON GPS1** or **BOTH ON GPS2** system annunciation does not necessarily mean that one GPS has failed. Refer to the MFD – GPS STATUS page to determine the state of the unused GPS.

General considerations

The route planning and WFDE prediction program may be downloaded from the GARMIN website on the internet. For information on using the WFDE Prediction Program, refer to GARMIN WAAS FDE Prediction Program, part number 190-00643-01, 'WFDE Prediction Program Instructions'.

Garmin International holds an FAA Type 2 Letter of Acceptance (LOA) in accordance with RTCA/DO-200A and AC 20-153B for database integrity, quality, and database management processes for many of its aviation databases. LOA status and RTCA/DO-200A List of Applicable Avionics (190-01999-00) can be viewed at FlyGarmin.com.

Navigation information is referenced to WGS-84 reference system, and should only be used where the Aeronautical Information Publication (including electronic data and aeronautical charts) conform to WGS-84 or equivalent.

GNSS (GPS/SBAS) navigation system limitations

Navigation database limitations

The pilot must confirm at system initialization that the Navigation database is current.

If the AIRAC cycle will change during flight, the pilot must ensure the accuracy of navigation data, including suitability of navigation facilities used to define the routes and procedures for flight. If an amended chart affecting navigation data is published for the procedure, the database must not be used to conduct the procedure.

GPS/SBAS based IFR enroute, oceanic, and terminal navigation is prohibited unless the pilot verifies and uses a valid, compatible, and current Navigation database or verifies each waypoint for accuracy by reference to current approved data.

Discrepancies that invalidate a procedure must be reported to Garmin International. The affected procedure is prohibited from being flown using data from the Navigation database until a new Navigation database is installed in the airplane and verified that the discrepancy has been corrected.

Contact information to report Navigation database discrepancies can be found at www.Garmin.com>Support>Contact Garmin Support>Aviation. Pilots and operators can view navigation data base alerts at www.Garmin.com>In the Air>NavData Alerts.

RNP APCH including “GPS”, “or GPS”, “RNAV (GPS)” and “RNAV (GNSS)” instrument approaches using the Garmin integrated flight deck are prohibited unless the pilot verifies and uses the current Navigation database. GPS based instrument approaches must be flown in accordance with an approved instrument approach procedure that is loaded from the Navigation database into the flight plan by its name.

Not all published Instrument Approach Procedures (IAP) are in the Navigation database.

Manual entry of waypoints using latitude/longitude or place/bearing is prohibited for published RNP and RNAV routes.

Whenever possible, RNP and RNAV routes including Standard Instrument Departures (SIDs) and Obstacle Departure Procedures (ODPs), Standard Terminal Arrival (STAR), and enroute RNAV Q and RNAV T routes should be loaded into the flight plan from the database in their entirety, rather than loading route waypoints from the database into the flight plan individually. Selecting and inserting individual named fixes from the database is permitted, provided all fixes along the published route to be flown are inserted.

GNSS integrity limitations

For flight planning purposes, in areas where SBAS coverage is not available, the pilot must check RAIM availability. The availability of GPS integrity RAIM shall be confirmed for the intended route of flight.

In the event of a predicted continuous loss of RAIM of more than five minutes for any part of the intended route of flight, the flight should be delayed, cancelled, or re-routed on a track where RAIM requirements can be met.

For flight planning purposes, in Remote Continental and Oceanic areas, the pilot must check FDE availability. Refer to the Table 2.6.1 - GNSS operational requirements, to check maximum authorized FDE unavailability and WFDE Prediction program references.

Approach operations limitations

LNAV+V feature is a standard LNAV approach with advisory vertical guidance provided for assistance in maintaining a constant vertical glidepath similar to an ILS glideslope on approach. This guidance is displayed on the PFD in the same location as the ILS glideslope using a magenta diamond. In all cases where LNAV+V is indicated by the system during an approach, LNAV minima shall be used.

Use of the GARMIN GPS/SBAS receivers to provide navigation guidance during the final approach segment of an ILS, LOC, LOC-BC, LDA, SDF, MLS or any other type of approach not approved for "or GPS" navigation is prohibited.

When using the VOR/LOC/GS receivers to fly the final approach segment, VOR/LOC/GS navigation data must be selected and presented on the CDI of the pilot flying.

Use of Baro-VNAV to a DA is not authorized with a remote altimeter setting. A current altimeter setting for the landing airport is required. When using remote altimeter minima, the Baro-VNAV function may be used to the published LNAV MDA.

Procedures with RF legs (Radius to Fix legs)

At the minimum, the flight director must be displayed and utilized when conducting procedures containing RF legs.

Advisory visual approaches**▲ WARNING ▲**

Use of advisory visual approaches in IMC is prohibited.

Advisory visual approaches are intended to be used as an aid to situational awareness and do not guarantee terrain or obstruction clearance along the approach path.



Icing conditions

Except for certain phases of flight where the POH specifies that deicing boots should not be used (e.g. take-off, final approach, and landing), compliance with the following is required.

Wing and Tail Leading Edge Pneumatic Deicing Boot System must be activated:

- At the first sign of ice formation anywhere on the aircraft, and
- The system must either be continued to be operated in the automatic cycling mode, if available; or the system must be manually cycled as needed to minimize the ice accretions on the airframe.

The wing and tail leading edge pneumatic deicing boot system may be deactivated only after leaving icing conditions and after the airplane is determined to be clear of ice.

In any case of icing conditions, first refer to Particular procedures described in chapter 4.5 and in case of unforeseen icing conditions, refer in addition to the Emergency procedure described in chapter 3.12.

Severe icing conditions

▲ WARNING ▲

Severe icing may result from environmental conditions outside of those for which the airplane is certificated. Flight in freezing rain, freezing drizzle, or mixed icing conditions (supercooled liquid water and ice crystals) may result in ice build-up on protected surfaces exceeding the capability of the ice protection system, or may result in ice forming aft of the protected surfaces. This ice may not be shed using the ice protection systems, and may seriously degrade the performance and controllability of the airplane.



During flight, severe icing conditions that exceed those for which the airplane is certificated shall be determined by the following visual cues. If one or more of these visual cues exists, immediately request priority handling from air traffic control to facilitate a route or an altitude change to exit the icing conditions.

- Unusually extensive ice accumulation on the airframe and windshield in areas not normally observed to collect ice.
- Accumulation of ice on the upper surface of the wing aft of the protected area.

Since the autopilot, when operating, may mask tactile cues that indicate adverse changes in handling characteristics, use of the autopilot is prohibited when any of the visual cues specified above exist, or when unusual lateral trim requirements or autopilot trim warnings are encountered while the airplane is in icing conditions.

All wing icing inspection lights must be operative prior to flight into icing conditions at night.

• NOTE •

This supersedes any relief provided by the Master Minimum Equipment List (MMEL).

•

Refer to the list of equipment required depending on type of operation in this same chapter.

Refer to Particular procedures described in chapter 4.5 and in case of unforeseen icing conditions, refer in addition to the Emergency procedure described in chapter 3.12.

Flap operating envelope

The use of flaps is not authorized above 15 000 ft.

Reverse utilization

The use of control reverse BETA (β) range is prohibited :

- during flight,
- on ground, if the engine is not running.

Weather radar GWX 70

On ground, the radar radiation is inhibited when the landing gear shock absorbers are compressed. However, it is important to obey the following restrictions :

- Do not operate the radar during refueling operations or in the vicinity of trucks or containers containing flammables or explosives.
- Do not allow personnel within 12 feet of area being scanned by antenna when system is transmitting.

Equipment required depending on type of operation

The airplane is approved for day & night VFR and day & night IFR operations when appropriate equipment is installed and operating correctly.

The type certification for each use requires the following equipment. The equipment must be installed and operate perfectly according to the indicated type of use.

▲ CAUTION ▲

It is the pilot's responsibility to check that the following equipment lists are in accordance with the specific national operation rules of the airplane registration country depending on the type of operation.



▲ CAUTION ▲

Systems and equipment mentioned hereafter do not include specific flight and radio-navigation instruments required by decree concerning operation conditions for civil airplanes in general aviation or other foreign regulations (for example FAR PART 91 and 135).



Day VFR

1. Pilot instruments
 - Airspeed indicator
 - Sensitive and adjustable altimeter
 - Magnetic compass with built-in compensator
2. CAS warning and caution messages
 - Oil pressure
 - Low fuel pressure
 - Fuel selector OFF
 - Fuel auxiliary pump ON
 - L.H. and R.H fuel tank low level
 - Non functioning of fuel timer
 - Battery stop
 - Main generator OFF
 - Low voltage
 - Ground power unit connected
 - Inertial separator
 - Starter
 - Ignition
 - Flaps
 - Landing gears and doors
3. Aural warning
 - V_{MO} warning
 - Landing gear warning
 - Stall warning

4. Engine instruments
 - Torquemeter
 - Propeller tachometer
 - Interturbine temperature indicator (ITT)
 - Gas generator tachometer (Ng)
 - Oil pressure indicator
 - Oil temperature indicator
5. Various indicators
 - Fuel gauge indicators (2)
 - Voltmeter
 - Ammeter
 - Outside air temperature
6. Installations
 - Fuel mechanical pump (main)
 - Fuel electrical pump (auxiliary)
 - Fuel shut-off valve
 - Fuel timer
 - Starter generator
 - Inertial separator
 - Stall warning
 - Electrical aileron trim
 - Electrical rudder trim
 - Manual elevator pitch trim
 - Engine ignition
 - Landing gear electro-hydraulic unit
 - Landing gear emergency hydraulic pump (manual)
 - Flaps
 - Overspeed regulator
 - Electrical feathering
 - Battery

7. Miscellaneous
 - Seats (each occupant)
 - Belts (each occupant)
 - Straps (each occupant)
 - Pilot's operating handbook

Night VFR

1. All equipment required for day VFR
2. Attitude display indicator
3. Instrument lighting
4. Instrument panel lighting
5. Emergency lighting
6. Vertical speed indicator
7. Navigation lights (4)
8. Anticollision lights (2)
9. Landing light

IFR

1. All equipment required for day VFR
2. All equipment required for night VFR, if flight is performed during night
3. Taxi light, if flight is performed during night
4. Clock
5. 2nd altimeter
6. Emergency static source
7. Pitot static tube deicing

Pressurized flight

1. Cabin altimeter
2. Cabin vertical speed indication
3. Cabin differential pressure indication
4. Pressurization control valve
5. Safety valve
6. Pressurization control
7. Maximum cabin altitude and pressure warning light

Flight into icing conditions

1. All equipment required for IFR flight
2. Propeller deicing
3. L.H. windshield deicing
4. Airframe, stabilizer and elevator horn deicing
5. Wing leading edge inspection light, if night flight
6. Stall warning deicing
7. Inertial separator
8. Garmin annunciation "Airspeed"

Altitude operating limits

Maximum altitude : 31000 ft (9449 m)

Maximum differential pressure : 6.2 psi

Operation in RVSM area

This airplane is approved for operations in Reduced Vertical Separation Minimum (RVSM) airspace when required equipment is maintained in accordance with the airplane maintenance manual - refer to section List of equipment, paragraph List of critical RVSM equipment.

This does not constitute operational approval. Individual airplane and operational approval must be obtained in accordance with applicable operating rules.

Each operator must ensure compliance with required crew training and operating practices and procedures.

Moreover, the following equipment must be installed and operating normally upon entering RVSM airspace :

- Pilot and R.H. station primary altimeters
- Autopilot
- Altitude alerter
- ATC transponder

● NOTE ●

Any changes to the pitot / static, air data computer, autopilot, altitude alerting and / or transponder systems, or other changes that affect operation of these systems must be evaluated for impact on the RVSM approval.

The standby altimeter is not approved for RVSM operations.



In-flight breaker use limits

A tripped breaker should not be reset in flight unless deemed necessary for continued safe flight and landing. Only one reset should be attempted.

Enhanced mode S

The installed mode S system satisfies the data requirements of ICAO Doc 7030/4, regional supplementary procedures for SSR mode S enhanced surveillance in designated european airspace. The capability to transmit data parameters is shown in column 2 :

Parameter	Available (A) / Not available (NA)
Magnetic heading	A
Indicated airspeed	A
Mach No	A
Vertical rate	A
Roll angle	A
True airspeed	A
True track angle	A
Groundspeed	A
Selected altitude	A
Barometric pressure setting	A

Chartview system operating limitations

The geographic-referenced airplane symbol on some charts must not be used for navigation.

• NOTE •

The airplane symbol displayed on some charts provides supplemental airplane situational awareness information. It is not intended as a means for navigation or flight guidance. The airplane symbol is not to be used for conducting instrument approaches or departures, and it should not be relied upon during low visibility taxi operations. Position accuracy, orientation, and related guidance must be assured by other means of required navigation.



Operators must have back-up charts available to the flight crew.

Database currency must be verified prior to use via database effectivity page.

The flight crew is responsible for verifying availability of charts for the planned flight.

Intentionally left blank

2.7 - Miscellaneous limits

Seating limits C.G.

- 2 front seats at 178.5 in (4.534 m)
>> *With 4-seat accommodation or 6-seat accommodation*
- 2 intermediate seats at 224.8 in (5.710 m)
>> *With 6-seat accommodation*
- Rear bench (2 seats) at 267.1 in (6.785 m)

Baggage limits

- Baggage in pressurized cabin at 303 in (7.695 m)
- Baggage in non pressurized forward section at 128 in (3.250 m)

Minimum crew

- One pilot at L.H. front seat

Maximum occupancy

The number of persons on board is limited by approved seating configuration installed but must not exceed six, including the pilot.

The number of persons must be less than or equal to the number of seats.

Use of doors

Flight with door open or ajar is prohibited.

Chemical toilet cabinet, if installed

The cabinet must be stowed during takeoff and landing. No baggage on the top of the cabinet for the whole flight.

Cargo net installation limits

Small cargo net : maximum loading height = 28 in (710 mm)

Large cargo net : maximum loading height = 22 in (565 mm) in cabin, out of baggage compartment.

▲ CAUTION ▲

No item may extend forward of the cargo net system to protect door from obstruction.



Weather radar limitation

Weather radar can be displayed on :

- PFD 1,
- PFD 2,
- MFD, with different indications of mode.

Example :

- PFD 1 : "SBY" MODE
- MFD : "SBY" MODE
- PFD 2 : "ACTIVE" MODE

▲ CAUTION ▲

The radar is OFF only when all displays indicate OFF.



2.8 - Markings

Airspeed indicator on PFD(s) and on Standby airspeed indicator

- Markings and their color code significance are shown in figure 2.8.1.

Marking	KIAS (Value or range)	Significance
Red strip	Below 65	/
White strip	65 - 122	Full flap operating range Lower limit is maximum weight V_{SO} in landing configuration.
Green strip	122 - 266	Normal operating airspeed range
Red/white barber pole strip	Above 266	266 = VMO

Figure 2.8.1 - Airspeed indicator markings

Pressurization

Marking	Value	Significance
Red line	6.2 psi	Cabin ΔP limit

Figure 2.8.2 - Pressurization marking

Engine instruments

Engine instrument markings and their color code significance are shown in figure 2.8.3.

Indication	Red line or arc ----- Minimum limit	Yellow line or arc ----- Caution range	Green line or arc ----- Normal operating	Red line ----- Maximum limit
Oil temperature	- 40 °C (- 40 °F)	- 40 to 0 °C (- 40 to 32 °F) 104 to 110 °C (219.2 to 230 °F)	0 to 104 °C (32 to 219.2 °F)	110 °C (230 °F)
Oil pressure	60 psi	60 to 105 psi	105 to 135 psi	135 psi (red line) normal limit
Generator RPM (Ng)	---	---	51 to 104 %	104 %
Propeller RPM (Np)	---	450 to 1000 RPM	1950 to 2050 RPM	2050 RPM
ITT Engine start or off	---	840 to 1090 °C (1544 to 1994 °F)	400 to 840 °C (752 to 1544 °F)	840 °C (1544 °F) normal limit ----- 870 °C (1598 °F) (< 20 seconds limit) ----- 1090 °C (1994 °F) (red line) absolute limit
Engine running	---	---	400 to 840 °C (752 to 1544 °F)	840 °C (1544 °F) normal limit
Torque (TRQ)	---	100 %	0 to 100 %	101 %

Figure 2.8.3 - Engine instrument markings

2.9 - Placards

- (1) Under L.H. front side window

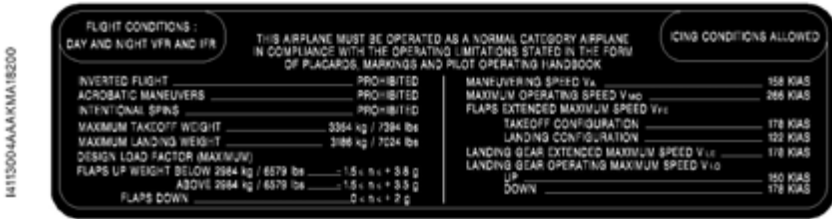

- (2) Calibration chart on compass and on windshield post



For	N	30	60	E	120	150
Steer						
For	S	210	240	W	300	330
Steer						

DATE : _____ RADIO ON

- (3) On pressurized baggage compartment partition wall

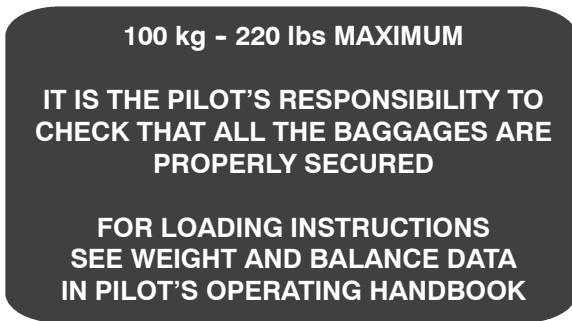

- (3)a For the small cargo net, on frame C13bis or on the right lower upholstery panel

I4113500AAAAMA18000

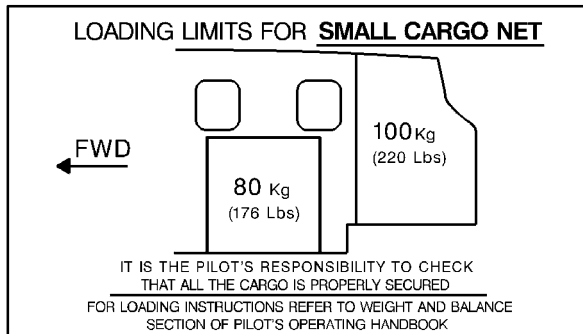

- (3)b For the large cargo net, on R.H. side upholstery panel, in the rear baggage compartment

I4113500AAAAMA18100

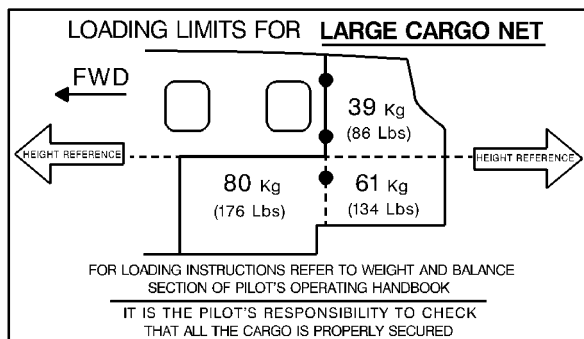

- (3)c On FWD baggage compartment door frame (non pressurized)

50 kg - 110 lbs MAXIMUM

**FOR LOADING INSTRUCTIONS
 SEE WEIGHT AND BALANCE DATA
 IN PILOT'S OPERATING HANDBOOK**

- (4) On pedestal console

I4113600A/AA/MA/8001



- (5) On fuel selector

I413006A/AL/MA/8000



- (6) Near fuel tank caps

JET-A-FUEL
TOTAL CAPACITY 150.5 us gal - 570 l
ANTHICE ADDITIVE REQUIRED.SEE PILOT'S
OPERATING HANDBOOK FOR OTHER APPROVED
FUELS QUANTITY AND TYPE OF ADDITIVE

I411200A/AA/MA/8200



- (7) On internal face of L.H. engine cowling

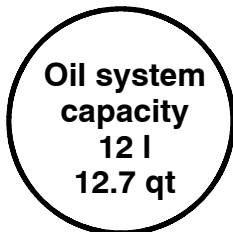

- (8) On landing gear emergency control access door



- (9) Under window, at L.H. Intermediate seat



- (10) On rear passenger's table casing



- (11) Under R.H. control wheel

I4351000AAACMA8000



- (12) On nose gear door

I4112001AAACMA8000

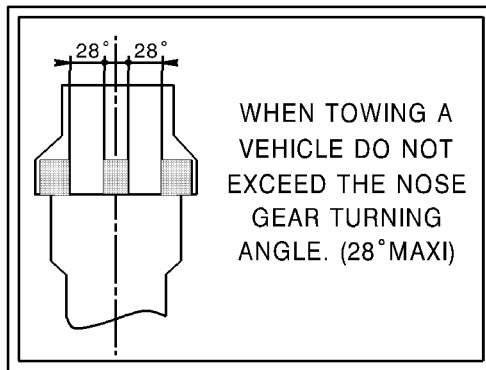

- (13) On nose gear leg

**NOSE LANDING GEAR
TIRE PRESSURE : 6,5 bar
94 psi**

- (14) On main gear leg

**MAIN LANDING GEAR
TIRE PRESSURE : 8,96 bar
130 psi**

- (15) On engine cowling, in front of compartment door

**EXTERNAL POWER
28 VOLTS D.C. NOMINAL
800 AMP
STARTING CAPACITY MIN
DO NOT EXCEED 1000 AMP**

- (16) On pilot door - External side, if installed

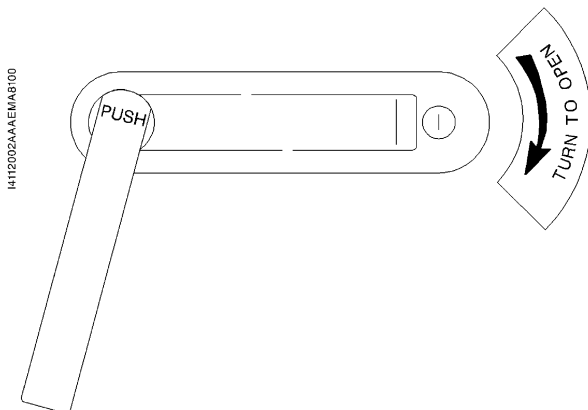

- (17) On access door - External side

I4112002AAEM/A8000



- (18) On outer fuselage skin aft of access door and in the cabin forward of access door



- (19) On access door - Internal side



- (20) On pilot door - Internal side, if installed



- (21) On emergency exit handle
Marking on cover



- Marking on handle



- (22) On last step of stairs



STAIRS MAX LOAD : ONE PERSON

- (23) On R.H. access door jamb



**DO NOT USE
HAND RAIL
TO RETRACT
OR STOW
STAIRS**

- (24) On R.H. side at front seat level and on the first rear passengers masks container (R.H. side on the ceiling)



**WARNING
GREASY SUBSTANCES ARE CAPABLE
OF SPONTANEOUS COMBUSTION
ON CONTACT WITH OXYGEN
DO NOT SMOKE WHILE OXYGEN IS IN USE**

- (25) On rear passengers masks containers



**OXYGEN MASKS INSIDE
PULL MASKS FOR
OXYGEN SUPPLY** ↓

- (26) On internal face of the oxygen cylinder service door

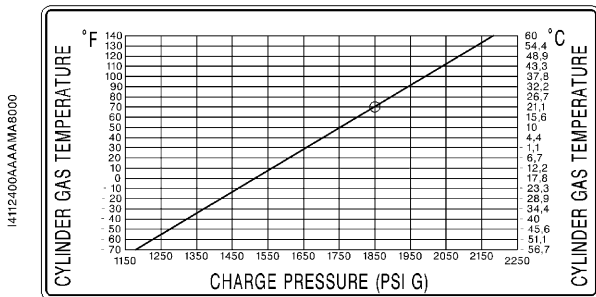

- (27) On the oxygen service door

I4112400AAAAA/MA8100



- (28) On emergency locator transmitter inspection door

I4112200AAAAA/MA8000



- (29) On the potty seat curtain, if installed, on pilot's side

CURTAIN MUST BE STOWED FOR TAKE-OFF AND LANDING

>> *Airplane equipped with coat hanger (Post-MOD70-0557-25B)*

(30) On the L.H. rear cargo compartment panel upper edge

14113200AAALMA8000

CLOTHING ONLY

>> *Airplane equipped with coat hanger (Post-MOD70-0557-25C)*

(31) On the L.H. rear cargo compartment panel upper edge

14113200AAALMA8300

MAX WEIGHT CAPACITY 4,5kg - 10 lbs

Intentionally left blank

Section 3

CAS messages

Table of contents

• NOTE •

CAS MESSAGES are in alphabetical order by either Chapter, Section, Paragraph or Supplement

•

ABORT APR	3.12.23
AP ON YD OFF	3.12.19
APR DWNGRADE	3.12.24
AURAL WRN 1 CHNL	3.12.8
AURAL WRN FAIL	3.12.7
AUTO SEL	3.8.5
AUX BOOST PMP ON	3.8.3
BAT AMP	3.9.1
BAT OFF	3.9.1
CABIN ALTITUDE and USE OXYGEN MASK	3.10.6
CABIN ALTITUDE and USE OXYGEN MASK and EDM ...	3.10.7
CABIN DIFF PRESS	3.10.9
CARGO DOOR	3.12.16
CHIP	3.3.11
DOOR	3.10.12
EDM	3.10.8
EDM OVERRIDE	Advisory
ELEC FEATH FAULT	3.9.7
ESP DEGRADED - AOA	3.12.11
ESP DEGRADED - IAS	3.12.10
ESP FAIL	3.12.9
ESP OFF	Advisory
FIRE	If installed - Supplement 18
FLAPS ASYM	3.7.3

FUEL IMBALANCE	3.8.6
FUEL LOW L	3.8.4
FUEL LOW R	3.8.4
FUEL OFF	7.7.1
FUEL PRESS	3.8.1
GAS DEGRADED	3.10.4
GAS EVENT	3.10.3
GEAR UNSAFE	3.7.5
GPU DOOR	3.12.17
GWX FAIL	3.12.34
IGNITION	3.12.18
INERT SEP FAIL	3.11.3
INERT SEP ON	Advisory
ITT	3.3.10
LOW LVL FAIL L	3.8.7
LOW LVL FAIL R	3.8.7
LOW VOLTAGE	3.9.3
MAIN GEN	3.9.2
MAIN GEN and LOW VOLTAGE	3.9.4
MAX DIFF MODE	Advisory
NG HI	3.3.11
OIL PRESS	3.3.4
OIL TEMP	3.3.12
O2 CYL CLOSED	3.10.11
PARK BRAKE	7.5.10
PITOT HT ON L	7.13.3
PITOT HT ON R	7.13.3
PITOT NO HT L	3.11.6
PITOT NO HT R	3.11.6
PRESSU BACKUP	3.10.5
PRESSU OFF	3.10.1
PROP DEICE FAIL	3.11.2
PROP DEICE ON	7.13.2

STALL HEAT ON	7.13.3
STALL NO HEAT	3.11.7
STARTER	Advisory
TCAS FAIL	3.12.35
TRAFFIC FAIL	3.12.36
USP ACTIVE	3.12.6
VACUUM LOW	3.10.13
XPDR1 ADS-B FAIL	3.12.33
XPDR1 FAIL	3.12.32
XPDR2 ADS-B FAIL	3.12.33
XPDR2 FAIL	3.12.32

Intentionally left blank

Section 3

Emergency procedures

Table of contents

3.1	-	General	3.1.1
		Procedure format	3.1.3
3.2	-	Rejected takeoff	3.2.1
		Engine failure at takeoff before rotation	3.2.1
		Rejected takeoff for any other reason	3.2.2
3.3	-	Engine failures	3.3.1
		Engine failure before rotation	3.3.1
		Engine failure after rotation	3.3.1
		Engine failure in flight	3.3.3
		OIL PRESS or OIL PRESS	3.3.4
		Engine regulation discrepancy, power loss, throttle control loss	3.3.5
		Governor control not operating	3.3.8
		Excessive propeller rotation speed	3.3.8
		Engine does not stop on ground	3.3.9
		ITT	3.3.10
		CHIP	3.3.11
		NG HI	3.3.11
		OIL TEMP	3.3.12
3.4	-	Air start	3.4.1
		Air start envelope	3.4.1
		Air start procedures	3.4.2

3.5	-	Fire and smoke	3.5.1
		Engine fire on ground	3.5.1
		Cabin fire on ground	3.5.2
		Engine fire in flight	3.5.3
		Cabin electrical fire or smoke during flight	3.5.4
		Smoke elimination	3.5.5
3.6	-	Emergency descents	3.6.1
		Emergency descents profiles	3.6.1
		Maximum rate descent	3.6.2
		Maximum range descent	3.6.3
3.7	-	Emergency landings, flaps, gear	3.7.1
		Forced landing	3.7.1
		Tire blowout during landing	3.7.2
		FLAPS ASYM	3.7.3
		Flaps malfunction	3.7.4
		Landing with flaps malfunction	3.7.4
		Landing gear retraction discrepancy	3.7.5
		Landing gear extension discrepancy	3.7.6
		Emergency gear extension	3.7.7
		Landing with unlocked main landing gear	3.7.10
		Landing with defective nose landing gear (down unlocked or not down)	3.7.12
		Landing with gear up	3.7.13
		Ditching	3.7.14
		Landing without elevator control	3.7.15
3.8	-	Fuel system	3.8.1
		FUEL PRESS	3.8.1
		AUX BOOST PMP ON	3.8.3
		FUEL LOW L-R	3.8.4
		AUTO SEL	3.8.5
		FUEL IMBALANCE	3.8.6
		LOW LVL FAIL L-R	3.8.7

3.9	-	Electrical system	3.9.1
		BAT AMP	3.9.1
		BAT OFF	3.9.1
		MAIN GEN	3.9.2
		LOW VOLTAGE	3.9.3
		MAIN GEN and LOW VOLTAGE	3.9.4
		ELEC FEATH FAULT	3.9.7
		Bus bar	3.9.8
		Total loss of electrical power	3.9.11
3.10	-	Pressurization and air conditioning	3.10.1
		PRESSU OFF	3.10.1
		GAS EVENT	3.10.3
		GAS DEGRADED	3.10.4
		PRESSU BACKUP	3.10.5
		CABIN ALTITUDE and USE OXYGEN MASK	3.10.6
		CABIN ALTITUDE and USE OXYGEN MASK and EDM (Pre-MOD70-0657-34 and Pre-MOD70-0549-00E)	3.10.7
		EDM (Post-MOD70-0657-34 or Post-MOD70-0549-00E)	3.10.8
		CABIN DIFF PRESS	3.10.9
		Cabin not depressurized after landing	3.10.10
		O2 CYL CLOSED	3.10.11
		DOOR	3.10.12
		VACUUM LOW	3.10.13
		Defog malfunction	3.10.14

3.11	-	Deicing system	3.11.1
		Leading edges deicing failure	3.11.1
		PROP DEICE FAIL	3.11.2
		INERT SEP FAIL	3.11.3
		Windshield deicing failure	3.11.4
		Windshield misting or internal icing	3.11.5
		PITOT NO HT L-R	3.11.6
		STALL NO HEAT	3.11.7
3.12	-	Miscellaneous	3.12.1
		Trim runaway	3.12.1
		Crack in cockpit window or window panel	3.12.2
		Emergency exit use	3.12.3
		Emergency beacon (ELT) use	3.12.4
		Inadvertent spins	3.12.5
		AP off, stall warning	3.12.6
		USP ACTIVE	3.12.6
		AURAL WRN FAIL	3.12.7
		AURAL WRN 1 CHNL	3.12.8
		ESP FAIL	3.12.9
		ESP DEGRADED - IAS	3.12.10
		ESP DEGRADED - AOA	3.12.11
		Oxygen use	3.12.12
		Airspeed indicating system failure	3.12.14
		Flight into severe icing conditions	3.12.15
		CARGO DOOR	3.12.16
		GPU DOOR	3.12.17
		IGNITION	3.12.18
		AP ON YD OFF	3.12.19
		Autopilot or electric pitch trim malfunction	3.12.20
		Dual GPS/SBAS failure (DR or LOI annunciation on HSI) ..	3.12.21
		ABORT APR	3.12.23

APR DWNGRADE	3.12.24
PIT in A/P vertical mode during FD approach with vertical guidance	3.12.25
VDI or VDI on Approach	3.12.26
Left PFD failure	3.12.27
AHRS failure	3.12.28
ADC failure	3.12.30
MFD failure	3.12.31
XPDR1 FAIL or XPDR2 FAIL	3.12.32
XPDR1 ADS-B FAIL or XPDR2 ADS-B FAIL	3.12.33
GWX FAIL	3.12.34
TCAS FAIL	3.12.35
TRAFFIC FAIL	3.12.36

Intentionally left blank

3.1 - General

The recommended procedures for different failures or emergency situations are provided in this section.

Emergency procedures associated with optional or particular equipment that require pilot's operating handbook supplements are provided in section 9 Supplements.

The pilot must know procedures given in this section and be prepared to take appropriate action should an emergency arise.

Some emergency procedures are a part of pilot basic training. Although these emergencies are discussed here, this information is not intended to replace such training, but only to provide a source of reference and review.

It is important for the pilot to be familiar with standard emergency procedures.

Alarm system recall

Main failure or state modification of the different systems are provided by warning or caution messages appearing on CAS display.

The color code philosophy for CAS messages is the following :

- the **red** warning messages indicate a failure or a condition that requires an immediate action from the pilot,
- the **amber** caution messages indicate a failure or a condition that requires an action from the pilot as soon as practical and,
- the **white** advisory messages indicate a state of a system that does not require an action from the pilot.

Red or amber failure warnings are coupled with the lighting of

- a flashing red indicator/button



or

- a fixed amber indicator/button



Both indicators/buttons are located on the upper part of the L.H. instrument panel. When either one lights up, press it once to reactivate. It will go out and is ready to signal in the event of another failure. On the CAS display, the corresponding failure message remains ON as long as the failed condition exists.

The actions associated to the **red** warning or **amber** caution messages are described in this Section of the POH.

The information associated to the **white** advisory messages are described in the GARMIN Pilot's Guide.

Procedure format

PROCEDURE TITLES

Name of the procedure	1/X
-----------------------	-----

Procedure introduction or description of symptoms associated with the failure are presented like this at the beginning of the procedure.

1/X is written if the procedure extends over 2 pages or more.

MEMORY ITEMS

The memory items are indicated with a grey border box as shown hereafter :

The memory items are written like this.

Memory items are critical steps that must be executed quickly from memory without referring to POH or checklist.

CONDITIONAL STEPS

Conditions are presented like this :

- 1 - With related actions to perform indented inside.

VALIDITY / EFFECTIVITY

>> *Pre/Post-MOD70-xxxx-xx*

Before procedure title, represents a specific validity / effectivity for the entire procedure below. If nothing is specified, the procedure applies to all airplanes.

>> *Validity inside a procedure is presented like this*

- 1 - With actions related to this validity listed under.

CONTINUATION AND ENDING

The end of the entire procedure is indicated by :

End of procedure.

Procedure completion within the body of the procedure as a result of a condition is indicated by :

End of procedure ■

Continuation of a procedure on several pages is indicated by :

▶ *Continuing*

Continue ▶

LANDING DIRECTIVES

▶ Land as soon as possible ◀ means land on the nearest suitable runway.

▶ Land as soon as practical ◀ means land on the nearest suitable runway with convenient facilities.

CAS MESSAGES

Indicated as displayed in the MFD CAS window :

- **FUEL PRESS** means FUEL PRESS warning CAS message,
- **MAIN GEN** means MAIN GEN caution CAS message.
- **MAX DIFF MODE** means MAX DIFF MODE advisory CAS message.

ANNUNCIATIONS ON PFDs or MFD

Indicated as displayed in the PFD or MFD with specifying “annunciation” next to the message :

- **BOTH ON AHRS1** annunciation,
- **HDG** annunciation.

3.2 - Rejected takeoff**Engine failure at takeoff before rotation**

- | | | |
|-----|----------------|-------------|
| 1 - | THROTTLE | Flight IDLE |
| 2 - | Brakes | As required |

If the airplane cannot be stopped on the runway :

- | | | |
|-----|--------------------------|-----------|
| 3 - | THROTTLE | CUT OFF |
| 4 - | FUEL TANK SELECTOR | OFF |
| 5 - | Crash lever | Pull down |

If necessary :

- | | |
|-----|-------------------------------------------------|
| 6 - | Evacuate after the airplane has come to a stop. |
|-----|-------------------------------------------------|

End of procedure.

Rejected takeoff for any other reason

- 1 - THROTTLE Flight IDLE
- 2 - Reverse As required
- 3 - Brakes As required

If the airplane cannot be stopped on the runway :

- 4 - THROTTLE CUT OFF
- 5 - FUEL TANK SELECTOR OFF
- 6 - Crash lever Pull down

If necessary :

- 7 - Evacuate after the airplane has come to a stop.

End of procedure.

3.3 - Engine failures**Engine failure before rotation**

Perform procedure Engine failure at takeoff before rotation
Refer to chapter 3.2

*End of procedure.***Engine failure after rotation****1/2****► Fly the airplane ◀**

1 - MAN OVRD control Full forward

If power recovery successful :

► Fly the airplane using the MAN OVRD control for power ◀

2 - THROTTLE Flight IDLE

► Land as soon as possible ◀

*End of procedure ■**If power recovery unsuccessful :*

3 - MAN OVRD control Full backward

If height does not allow to choose a suitable landing surface :

► Land straight ahead without changing LANDING GEAR position ◀

4 - FLAPS lever TO

5 - Airspeed Maintain above 100 KIAS

6 - THROTTLE CUT OFF

Continue ►

Engine failure after rotation 2/2

► *Continuing*

7 - FUEL TANK SELECTOR OFF

Before touch down :

8 - FLAPS lever LDG

9 - Crash lever Pull down

10 - Evacuate airplane after coming to complete stop.
 Do not unfasten seat belts before complete stop.

End of procedure ■

If height allows to reach a suitable landing surface :

- 11 - LANDING GEAR lever DN
 12 - FLAPS lever As required

Maintain airspeeds	
Flaps UP	105 < KIAS < 178
Flaps TO	100 < KIAS < 178
Flaps LDG	85 < KIAS < 122

- 13 - THROTTLE CUT OFF

14 - FUEL TANK SELECTOR OFF

Before touch down :

15 - Crash lever Pull down

16 - Evacuate airplane after coming to complete stop.
 Do not unfasten seat belts before complete stop.

End of procedure.

Engine failure in flight

■ *Symptoms : Loss of power*

► Fly the airplane ◀

- | | | |
|-----|--------------------------|--------------|
| 1 - | FUEL TANK SELECTOR | Switch tanks |
| 2 - | AUX BP switch | ON |
| 3 - | Autopilot | Disconnect |

■ *If power recovery successful :*

- 4 - Remaining fuel Check

► Land as soon as possible ◀

End of procedure ■

■ *If power recovery unsuccessful :*

- | | | |
|-----|--------------------|---------|
| 5 - | THROTTLE | CUT OFF |
| 6 - | Oxygen masks | Use |

- 7 - Air start envelope Check
Refer to chapter 3.4

End of procedure.

OIL PRESS or **OIL PRESS**

■ Indicates that oil pressure is below 105 psi.

► Fly the airplane ◀

► Land as soon as possible ◀

1 - Oil pressure Monitor

2 - TRQ Minimum necessary

▲ CAUTION ▲

Due to the oil pressure drop, the propeller blade angle may go towards high pitch and therefore lead to a Np propeller rotation speed decrease.



If engine power decreases :

- 3 - THROTTLE CUT OFF
- 4 - Perform procedure Emergency descent
 Refer to chapter 3.6
- 5 - Perform procedure Forced landing
 Refer to chapter 3.7

End of procedure.

**Engine regulation discrepancy, power loss,
throttle control loss** 1/3

Symptoms :

- *power fluctuations, or*
- *uncommanded power loss, or*
- *bad response to THROTTLE movements.*

▶ **Fly the airplane** ◀

If circumstances and obtained minimum power allow :

▲ **CAUTION** ▲

In manual override mode, engine is neither protected against slam accelerations, nor against maximum speed overshooting. Avoid rapid control movements and manage engine parameters.



- | | | |
|-----|--------------------------------------------------------|-----------------------------------------------|
| 1 - | THROTTLE | Flight IDLE |
| 2 - | Confirm engine still running. | |
| 3 - | FUEL TANK SELECTOR | Switch tanks |
| 4 - | Check that no engine indication exceeds allowed value. | |
| 5 - | MAN OVRD control | Actuate
Progressively to minimum necessary |

6 - Continue the flight.

▶ Land as soon as possible ◀

If the available power is weak :

- 7 - LANDING GEAR lever DN
Only on a final approach glide path
- 8 - FLAPS lever LDG
Only in short final

Continue ▶

**Engine regulation discrepancy, power loss,
throttle control loss** 2/3

▶ *Continuing*

▲ CAUTION ▲

When MAN OVRD control is used, the available power may not be sufficient to ensure a go-around in landing configuration, particularly if the weight is near the maximum weight.



▶ Do not perform a go around ◀

▶ Do not use the reverse ◀

9 - Land normally.

10 - Brakes As required

End of procedure ■

If minimum power obtained is excessive :

- | | |
|-----------------------------|------------------------------------------------------|
| 11 - Airspeed | Reduce below 178 KIAS
By setting nose-up attitude |
| 12 - INERT SEP switch | ON |

If ITT > 840°C :

13 - INERT SEP switch OFF

14 - LANDING GEAR lever DN

15 - FLAPS lever TO

16 - Long final or ILS approach Establish
At IAS < 178 KIAS

Continue ▶

Engine regulation discrepancy, power loss,
throttle control loss

3/3

► *Continuing*

When runway is assured :

- 17 - THROTTLE CUT OFF
- 18 - FLAPS lever LDG as required
At IAS < 122 KIAS
- 19 - Land normally.
- 20 - Brakes As required

End of procedure.

Governor control not operating

► Fly the airplane ◀

1 - Continue the flight.

If $N_p < 1960$ RPM :

- Do not perform a go around ◀
- Do not use the reverse ◀

In that case, the go-around performance and the reverse efficiency might be lower than expected.

Repair before further flight.

End of procedure.

Excessive propeller rotation speed

► Fly the airplane ◀

1 - Reduce power and airplane speed to avoid propeller rotation speeds higher than 2050 RPM.

- Land as soon as possible ◀
- Do not perform a go around ◀

In that case, the go-around may damage the gear reduction box and the reverse efficiency might be lower than expected.

Repair before further flight.

End of procedure.

Engine does not stop on ground

If the engine does not stop when the THROTTLE is set to CUT OFF :

1 - FUEL TANK SELECTOR OFF

2 - Wait for engine stop due to lack of fuel in the pipes.

3 - GENERATOR selector OFF

4 - SOURCE selector OFF

5 - Crash lever Pull down

Inform maintenance department.

End of procedure.



During engine start :

1 - Starting procedure Abort
Refer to procedure Engine start, chapter 4.4

- 2 - Cancel the flight.
Inform maintenance department.

End of procedure ■

After engine start :

On ground :

- 3 - Cancel the flight.
Inform maintenance department.

End of procedure ■

In flight :

► Fly the airplane ◀

4 - TRQ Reduce
To get ITT < 840°C
► Land as soon as possible ◀

Inform maintenance department.

End of procedure.

CHIP

■ Indicates that metallic chips have been detected in the engine oil.

In flight :

▶ Fly the airplane ◀

▶ Land as soon as practical ◀

Inform maintenance department.

End of procedure ■

On ground :

▶ Do not take off ◀

Airplane is grounded.

Inform maintenance department.

End of procedure.

NG HI

Indicates that Ng speed is more than 103 %.

1 - TRQ Reduce
To get Ng below 103 %

End of procedure.

OIL TEMP

Indicates that oil temperature is below 0°C or above 104°C (possibly with **OIL PRESS**)

1 - Oil temperature indicator Check

If the indicated temperature is in the green sector :

▶ Land as soon as possible ◀

▶ Fly the airplane ◀

2 - Oil temperature Monitor

End of procedure ■

If the indicated temperature is not in the green sector :

Failure is confirmed, you can expect an oil pressure failure shortly.

▲ CAUTION ▲

Due to the oil pressure drop, the propeller blade angle may go towards high pitch and therefore lead to a Np propeller rotation speed decrease.



▲ CAUTION ▲

Prepare for an engine stop shortly.



3 - TRQ Minimum necessary

▶ Land as soon as possible ◀

If engine power decreases :

4 - THROTTLE CUT OFF

5 - Perform procedure Forced landing
Refer to chapter 3.7

End of procedure.

3.4 - Air start

Air start envelope

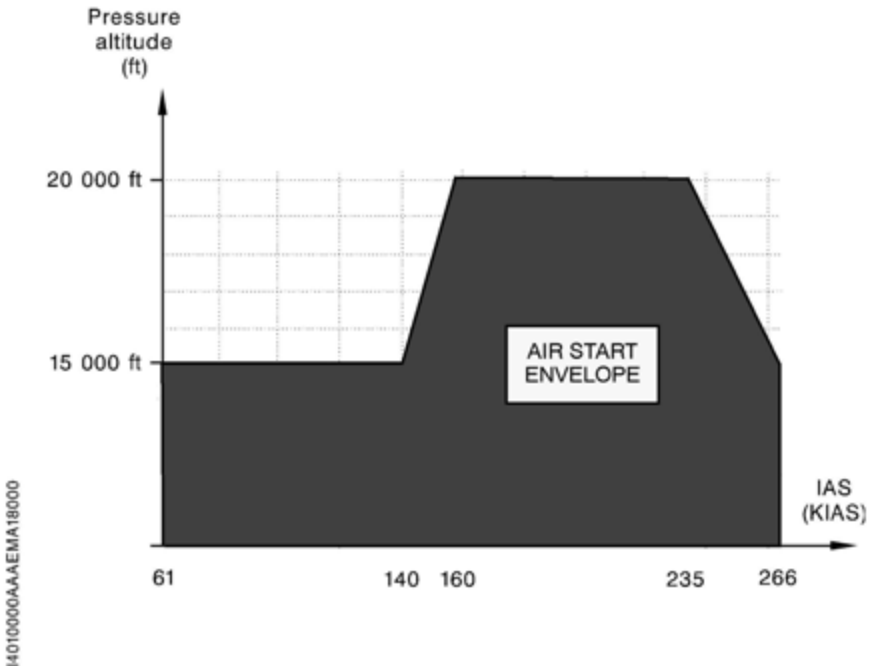

• NOTE •

Air start may be attempted outside of the envelope. However, above 20000 ft or at lower speeds, ITT tends to increase during start and prudence is recommended.

•

End of procedure.

Air start procedures	1/2
----------------------	-----

1 - Oxygen masks	Use
------------------------	-----

▲ **CAUTION** ▲

The starter cannot operate if the GENERATOR selector is on ST-BY.



2 - GENERATOR selector	MAIN
------------------------------	------

▲ **CAUTION** ▲

BLEED switch set to AUTO may cause overtemperature or abnormal acceleration.



3 - BLEED switch	OFF
------------------------	-----

4 - A/C switch	OFF
----------------------	-----

5 - Electric consumption	Reduce
--------------------------------	--------

6 - FUEL TANK SELECTOR	L or R
------------------------------	--------

7 - AUX BP switch	ON
-------------------------	----

● **NOTE** ●

Maintain AUX BP switch in ON position for the remainder of the flight.



8 - IGNITION switch	AUTO or ON
---------------------------	------------

9 - THROTTLE	CUT OFF
--------------------	---------

10 - STARTER switch	ON, start timer
---------------------------	-----------------

If there is no start after 5 seconds :

11 - STARTER switch	ABORT
---------------------------	-------

When Ng around 13 % :

12 - THROTTLE	LO-IDLE
---------------------	---------

13 - ITT and Ng	Monitor
-----------------------	---------

Continue ►

Air start procedures**2/2**▶ *Continuing**When Ng > 50 % :*

14 - Starter Check OFF automatically

If starter has not turned off automatically :

15 - STARTER switch ABORT

16 - THROTTLE Flight IDLE

17 - THROTTLE As required

18 - BLEED switch As required

19 - Electrical equipment As required

*If necessary :*20 - Perform procedure Emergency descent
Refer to chapter 3.6*If air start is not successful :*21 - Perform procedure Forced landing
Refer to chapter 3.7*End of procedure.*

Intentionally left blank

3.5 - Fire and smoke**Engine fire on ground**

Symptoms : ITT increasing, **ITT** , smoke, ...

- | | |
|------------------------|---------|
| 1 - THROTTLE | CUT OFF |
| 2 - BLEED switch | OFF |
| 3 - A/C switch | OFF |

- 4 - Brakes As required
5 - FUEL TANK SELECTOR OFF

If necessary :

- 6 - Warn ground assistance.
7 - Crash lever Pull down

► Evacuate as soon as possible ◀

End of procedure.

Cabin fire on ground

1 - THROTTLE CUT OFF

2 - Brakes As required

If necessary :

3 - Warn ground assistance.

4 - Crash lever Pull down

5 - Cabin extinguisher As required

► Evacuate as soon as possible ◀

End of procedure.

Engine fire in flight

Symptoms : ITT increasing, **ITT** , smoke, ...

▲ WARNING ▲

No air start attempt after an engine fire.



► Fly the airplane ◀

- 1 - Oxygen masks Use
- 2 - THROTTLE CUT OFF
- 3 - AUX BP switch OFF
- 4 - FUEL TANK SELECTOR OFF

5 - BLEED switch OFF

6 - A/C switch OFF

If necessary :

7 - Perform procedure Emergency descent
Refer to chapter 3.6

8 - Perform procedure Forced landing
Refer to chapter 3.7

End of procedure.

Cabin electrical fire or smoke during flight

▶ Fly the airplane ◀

- | | |
|------------------------------------|-----|
| 1 - Oxygen masks and goggles | Use |
|------------------------------------|-----|

If the origin is known :

- 2 - Defective equipment breaker Pull
- 3 - Cabin extinguisher Use

If the origin is unknown :

- 4 - A/C switch OFF
- 5 - All unnecessary equipment OFF
- 6 - Perform procedure Emergency descent
Refer to chapter 3.6

If necessary :

- 7 - Perform procedure Smoke elimination
Refer to procedure hereafter

▶ Land as soon as possible ◀

End of procedure.

Smoke elimination

- 1 - Oxygen masks and goggles Use
- 2 - BLEED switch OFF
- 3 - A/C switch OFF
- 4 - DUMP switch Actuate
- 5 - Wait until the differential pressure drops.
- 6 - EMERGENCY RAM AIR control knob Pull

If smoke decreases :

► Land as soon as possible ◀

End of procedure ■

If smoke increases :

- 7 - EMERGENCY RAM AIR control knob Push

► Land as soon as possible ◀

End of procedure.

Intentionally left blank

3.6 - Emergency descents

Emergency descents profiles

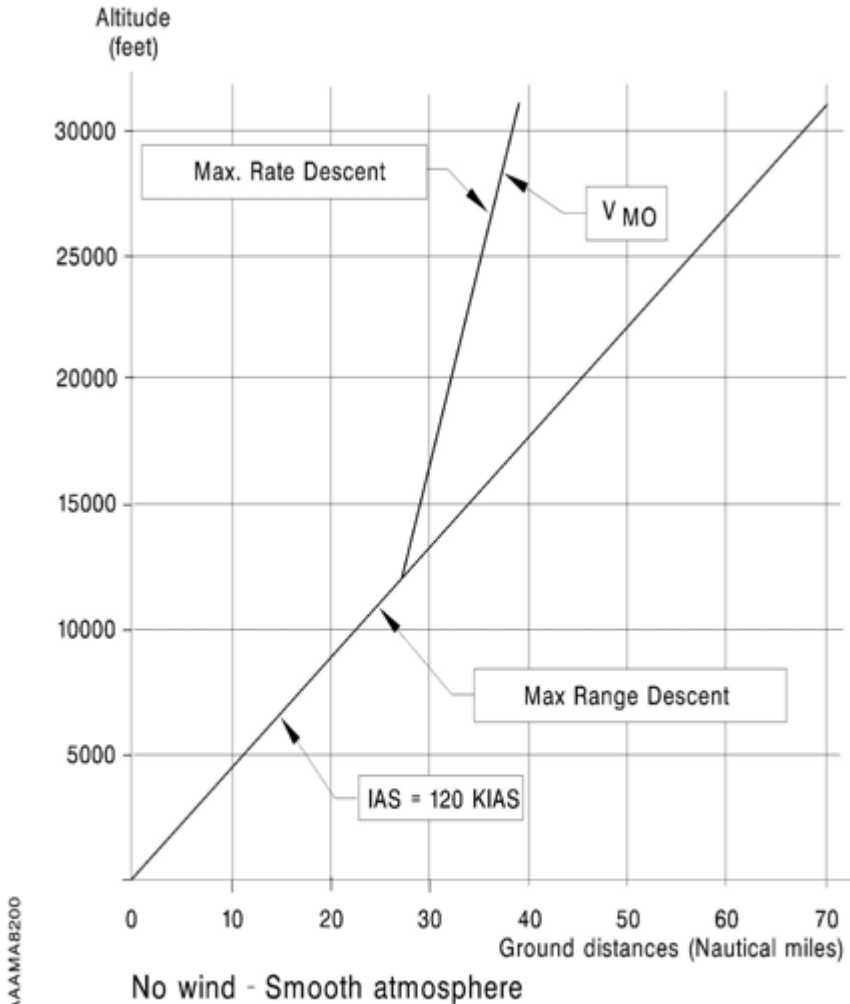

Maximum rate descent

- 1 - THROTTLE Flight IDLE
- 2 - Oxygen masks Use
- 3 - Pitch attitude - 10° to - 20°

If smooth air :

- 4 - FLAPS and LANDING GEAR levers UP
- 5 - Airspeed $V_{MO} = 266$ KIAS

If rough air or in case of structure problem :

- 6 - Airspeed Below 178 KIAS
- 7 - FLAPS lever UP
- 8 - LANDING GEAR lever DN

End of procedure.

Maximum range descent

1/2

- | | |
|------------------------------------|----------|
| 1 - Oxygen masks | Use |
| 2 - THROTTLE | CUT OFF |
| 3 - FLAPS and LANDING GEAR levers | UP |
| 4 - Airspeed | 120 KIAS |
| 5 - DUMP switch | Actuate |
| 6 - EMERGENCY RAM AIR control knob | Pull |

If VMC and non icing conditions are possible :

- | | |
|------------------------|----------------------------------------|
| 7 - ESS BUS TIE switch | EMER |
| 8 - Prepare for | Forced landing
Refer to chapter 3.7 |

End of procedure ■

If VMC and non icing conditions are not possible :

Breakers :

- | | |
|-------------|------|
| 9 - PFD 2 | Pull |
| 10 - ADC 2 | Pull |
| 11 - XPDR 2 | Pull |

Switches :

- | | |
|------------------------------|---------|
| 12 - DE ICE SYSTEM | All OFF |
| 13 - Lights | All OFF |
| 14 - BLEED | OFF |
| 15 - A/C | OFF |
| 16 - AUX BP | OFF |
| 17 - FUEL SEL | MAN |
| 18 - AP / TRIMS | OFF |
| 19 - DIMMER / CABIN / ACCESS | OFF |

Continue ►

Maximum range descent	2/2
-----------------------	-----

► *Continuing*

If icing conditions :

- 20 - PITOT L HTR switch ON
- 21 - WINDSHIELD switch ON
- 22 - Airspeed Above 135 KIAS
Configuration flaps UP

If time permits :

- 23 - PLUGS breakers Pull
- 24 - AIR COND breaker Pull
- 25 - Prepare for Forced landing
Refer to chapter 3.7

End of procedure.

3.7 - Emergency landings, flaps, gear**Forced landing**

- | | |
|------------------------------|---------|
| 1 - THROTTLE | CUT OFF |
| 2 - FUEL TANK SELECTOR | OFF |
| 3 - AUX BP switch | OFF |
-
- | | |
|------------------------------|------------------------------------------------------|
| 4 - BLEED switch | OFF |
| 5 - A/C switch | OFF |
| 6 - DUMP switch | Actuate |
| 7 - Gliding airspeed | Maintain 120 KIAS
Until favorable ground approach |
| 8 - ESS BUS TIE switch | NORM
To have GEAR and FLAPS available |

If landing surface is suitable :

- 9 - LANDING GEAR lever
- DN

If landing surface is not suitable :

- 10 - LANDING GEAR lever
- Keep UP

If night conditions :

- 11 - OFF/TAXI/LDG switch
- LDG

When chosen landing surface is assured :

- 12 - FLAPS lever
- LDG
- 13 - Crash lever
- Pull down
- 14 - Airspeed on final approach
- 85 KIAS
- 15 - Land flaring out.
- 16 - Evacuate after stop.

End of procedure.

Tire blowout during landing

- 1 - Control direction with brakes and nose wheel steering.
- 2 - Reverse As required
- 3 - Stop airplane to minimize damages.
- 4 - Perform procedure Shutdown
Refer to chapter 4.3
End of procedure.

FLAPS ASYM

Indicates a dissymmetry of flap deflection. This immediately stops the flap motor and prevents further operation of the flaps.

► Fly the airplane ◀

- | | | |
|-----|---------------------|------|
| 1 - | FLAPS breaker | Pull |
| 2 - | FLAPS lever | UP |

► Land as soon as possible ◀

- 3 - Maintain airspeeds :
- IAS < 178 KIAS for deflections between UP and TO positions
 - IAS < 122 KIAS for deflections greater than TO position
- 4 - For landing, refer to procedure Landing with flaps malfunction
Refer to procedure on following page
End of procedure.

Flaps malfunction

*In case of blockage of flaps or inoperative flaps control lever between UP and LDG positions, without **FLAPS ASYM** :*

- | | | |
|-----|---------------------|------|
| 1 - | FLAPS breaker | Pull |
| 2 - | FLAPS lever | UP |

▶ Land as soon as possible ◀

- 3 - Maintain airspeeds
 - IAS < 178 KIAS for deflections between UP and TO positions
 - IAS < 122 KIAS for deflections greater than TO position
- 4 - For landing, refer to procedure Landing with flaps malfunction
Refer to procedure hereafter
End of procedure.

Landing with flaps malfunction

For flaps deflections between UP and TO :

Proceed as for a normal landing with 105 KIAS of approach airspeed.
Provide for a landing distance increased by 60 %.

For flaps deflections greater than TO :

Proceed as for a normal landing with 100 KIAS of approach airspeed.
Provide for a landing distance increased by 50 %.

End of procedure.

Landing gear retraction discrepancy

• NOTE •

Symptoms have to be considered at the end of the sequence.

•

Symptoms :

- **GEAR UNSAFE** CAS msg and GEAR UNSAFE red warning light are ON, or
- amber light flashing and 3 green lights are OFF.

1 - Airspeed Maintain below 150 KIAS

2 - LDG GEAR breaker Pull

If **GEAR UNSAFE** CAS msg and GEAR UNSAFE red warning light are OFF :

3 - The flight may be continued without any restriction.

For landing gear extension :

4 - Perform procedure Emergency gear extension
Refer to following procedures

End of procedure ■

If not :

5 - LDG GEAR breaker Push

6 - Perform procedure Emergency gear extension
Refer to following procedures

End of procedure.

Landing gear extension discrepancy

• NOTE •

Symptoms have to be considered at the end of the sequence.

•

Symptoms :

- **GEAR UNSAFE** CAS msg and GEAR UNSAFE red warning light are ON, or
- amber light flashing and 0 to 3 green lights are OFF.

1 - Airspeed Maintain below 150 KIAS

- 2 - Perform procedure Emergency gear extension
Refer to procedure on following page

End of procedure.

Emergency gear extension 1/3

• NOTE •

Follow this procedure in case of any doubt about the gear extension.

▲ CAUTION ▲

Do not enter icing conditions. This could adversely increase drag and weight due to ice accumulation, and lock wheels and struts.

Climb performance will be degraded by 50 %.

Cruise IAS speed will be reduced compared to a clean airplane,
because of the drag.

This should be taken into account when calculating the airplane range.



- | | | |
|-----|--------------------------|-------------------------|
| 1 - | Airspeed | Maintain below 150 KIAS |
| 2 - | LANDING GEAR lever | DN |
| 3 - | LDG GEAR breaker | Pull |
| 4 - | Floor hatch | Open |
| 5 - | By-pass selector | Fully pull / Locked |

▲ CAUTION ▲

The entire extension of the landing gear may take up to 110 cycles. It is mandatory to have a clear hardening of the manual control at the end of the maneuver.



- | | | |
|-----|------------------------------------------|--------------------------------------------------------|
| 6 - | Landing gear emergency pump handle | Actuate
With maximum amplitude until pump hardening |
| 7 - | MASTER WARNING push-button | Press |
- To reset the **GEAR UNSAFE**

Continue ►

Emergency gear extension	2/3
--------------------------	-----

► *Continuing*

If :

- GEAR UNSAFE red warning light is OFF and
 - **GEAR UNSAFE** is OFF and
 - 3 green lights are ON :
 - 8 - Exit and / or remain outside icing conditions.
- Continue flight at airspeed < 178 KIAS.

► Land as soon as practical ◀

End of procedure ■

If :

- GEAR UNSAFE red warning light is ON and
- **GEAR UNSAFE** is ON and
- 0 to 3 green lights are ON :
 - 9 - LDG GEAR breaker Push
 - 10 - CHECK DOWN push-button Press

If :

- hardening of the pump is marked and
- 3 green lights are ON or
- 3 green lights are ON and flickering while pressing the CHECK DOWN push-button :
 - 11 - Land

End of procedure ■

Continue ►

Emergency gear extension

3/3

► *Continuing**If :*

- *emergency pump remains soft or*
- *one (or more) green light(s) is(are) not ON and / or flickering while pressing the CHECK DOWN push-button :*

A gear unlock condition is confirmed.

Recycle the landing gear as follows :

- 12 - By-pass selector Unlock / Push
- 13 - Wait one minute.
- 14 - LANDING GEAR lever UP
At airspeed < 150 KIAS
- 15 - Perform landing gear extension attempts in the normal mode while applying positive load factors during the maneuver as well as skidding.

In case of failure :

- 16 - Perform procedure Landing with unlocked
main landing gear
or Landing with defective nose landing gear
Refer to following procedures

▲ CAUTION ▲

If one main landing gear is not down, it is recommended to land with landing gear up - refer to procedure Landing with gear up in the following procedures.



End of procedure.

Landing with unlocked main landing gear	1/2
-----------------------------------------	-----

▲ CAUTION ▲

If one main landing gear is not down, it is recommended to land with landing gear up - refer to procedure Landing with gear up in the following procedures.



- 1 - Ask ATC or another airplane to visually check landing gear position.

If defective gear is down but unlocked :

- 2 - BLEED switch OFF
- 3 - DUMP switch Actuate
- 4 - FUEL TANK SELECTOR Maintain on defective LDG gear side
 To lighten corresponding wing (maximum fuel imbalance 15 USG)
- 5 - Choose a runway with headwind or crosswind blowing from defective gear side.
- 6 - Align the airplane to land on the runway edge opposite to the defective landing gear.
- 7 - Perform a normal approach.
- 8 - FLAPS lever LDG
 At airspeed = 90 KIAS
- 9 - Land and set nose gear immediately on ground to assure lateral control.
- 10 - Use full aileron during roll-out to lift the wing with the defective landing gear.

Continue ►

Landing with unlocked main landing gear**2/2**▶ *Continuing**If landing gear drags during landing :*

- 11 - THROTTLE CUT OFF
- 12 - Crash lever Pull down
- 13 - FUEL TANK SELECTOR OFF
- 14 - Evacuate after airplane comes to a stop.

End of procedure ■*If landing gear does not drag during landing :*

- 15 - Preferably do not use reverse.
- 16 - Complete taxiing with a slight turn towards defective landing gear.
- 17 - THROTTLE CUT OFF
- 18 - Perform procedure Shutdown
Refer to chapter 4.3
- 19 - Evacuate.

End of procedure.

**Landing with defective nose landing gear
(down unlocked or not down)**

- 1 - Ask ATC or another airplane to visually check landing gear position.

If necessary :

- 1 - Transfer passengers to the rear.
- 2 - Perform a normal approach.
- 3 - FLAPS lever LDG
- 4 - Airspeed Maintain 90 KIAS
- 5 - Land with nose-up attitude. Keep nose high.
- 6 - THROTTLE CUT OFF
- 7 - Touch down slowly with nose wheel and keep elevator at nose-up stop.
- 8 - Brakes Apply moderately
- 9 - Crash lever Pull down
- 10 - FUEL TANK SELECTOR OFF
- 11 - Evacuate after airplane comes to a stop.

End of procedure.

Landing with gear up

- 1 - Do a standard final approach.
- 2 - FLAPS lever LDG
- 3 - Airspeed Maintain 85 KIAS
- 4 - BLEED switch OFF
- 5 - DUMP switch Actuate

When runway is assured :

- 6 - THROTTLE CUT OFF
- 7 - FUEL TANK SELECTOR OFF
- 8 - Flare out.

After touch-down :

- 9 - Crash lever Pull down
- 10 - Evacuate after airplane comes to a stop.

End of procedure.

Ditching

▲ CAUTION ▲

In heavy swell with light wind, land parallel to the swell (rollers).
In heavy wind, land facing wind.



- 1 - LANDING GEAR lever UP
- 2 - FLAPS lever LDG
- 3 - Airspeed Maintain above 85 KIAS
- 4 - Maintain a descent rate as low as possible when approaching the water.
- 5 - BLEED switch OFF
- 6 - DUMP switch Actuate
- 7 - Crash lever Pull down
- 8 - Maintain attitude without flaring out until touch-down.
- 9 - Evacuate through EMERGENCY EXIT.

End of procedure.

Landing without elevator control

- 1 - LANDING GEAR lever DN
- 2 - FLAPS lever LDG
- 3 - Airspeed Maintain 95 KIAS
- 4 - TRQ As required
To maintain airspeed according to an easy approach slope \approx 300 ft/min
- 5 - Adjust elevator by using manual pitch trim wheel.

When ground approaches :

- 6 - Slope Decrease progressively
- 7 - TRQ Reduce progressively

End of procedure.

Intentionally left blank

3.8 - Fuel system**FUEL PRESS**

1/2

Indicates a fuel pressure drop at HP engine pump inlet.

► Fly the airplane ◀

- | | | |
|-----|--------------------------|--------------|
| 1 - | Remaining fuel | Check |
| 2 - | FUEL TANK SELECTOR | Switch tanks |
| 3 - | AUX BP switch | AUTO |

If **FUEL PRESS** remains ON :

- | | | |
|-----|---------------------|----|
| 4 - | AUX BP switch | ON |
|-----|---------------------|----|

- 5 -
- AUX BOOST PMP ON**
- Check ON

If pressure is normal again and **FUEL PRESS** is OFF :

Mechanical pump has failed.

- 6 - AUX BP switch Maintain ON

► Land as soon as practical ◀

*End of procedure ■*If **FUEL PRESS** remains ON :

- 7 - FUEL TANK SELECTOR Switch tanks

If **FUEL PRESS** is OFF :

A supply problem may have occurred from the tank selected first (air vent, fuel icing, etc...).

*End of procedure ■**Continue ►*

FUEL PRESS 2/2

► *Continuing*

If **FUEL PRESS** remains ON :

- 8 - Fullest tank Select
- 9 - Avoid high power and rapid movements of the THROTTLE.
- 10 - Altitude Below 18000 ft
 - Land as soon as possible ◀
 - Fly the airplane ◀

End of procedure.

AUX BOOST PMP ON

Indicates the auxiliary booster pump is running.

► Fly the airplane ◀

If AUX BP switch is in ON position :

Indication is normal.

End of procedure ■

If AUX BP switch is in AUTO position :

- 1 - Reset AUX BP switch to ON
- 2 - Then, AUX BP switch AUTO

If **AUX BOOST PMP ON** goes OFF :

- 3 - Continue the flight normally.

End of procedure ■

If **AUX BOOST PMP ON** remains ON :

Mechanical booster pump has failed.

- 4 - AUX BP switch ON

► Land as soon as possible ◀

End of procedure.

FUEL LOW L-R

Indicates a level drop in the corresponding tank.

- 1 - Corresponding gage Check
- 2 - Check the other tank has been automatically selected.

If other tank not automatically selected :

- 3 - FUEL SEL switch MAN
- 4 - Select tank manually As required

► Fly the airplane ◀

- 5 - Minimum fuel Check
- 6 - Take decision.

If necessary :

► Land as soon as practical ◀

End of procedure.

AUTO SEL

Indicates that there is no more automatic control mode running.

► Fly the airplane ◀

- 1 - FUEL SEL switch Check AUTO

If FUEL SEL switch already on AUTO :

Failure is confirmed.

- 2 - FUEL SEL switch MAN

- 3 - Select tanks manually As required

▲ CAUTION ▲

Maximum fuel imbalance is 15 USG



End of procedure.

FUEL IMBALANCE

Indicates that fuel tanks are imbalanced by more than 15 USG for more than 30 seconds.

If FUEL SEL switch is on AUTO :

- 1 - Fullest tank Select
By pressing the SHIFT push-button

If FUEL SEL switch is on MAN :

- 2 - Fullest tank Select
By shifting FUEL TANK SELECTOR manually

► Fly the airplane ◀

▲ CAUTION ▲

Maximum fuel imbalance is 15 USG



End of procedure.

LOW LVL FAIL L-R

Indicates a failure of fuel low level sensor.

- 1 - Remaining fuel in tanks Check
- 2 - Take decision.

If any doubt :

▶ Land as soon as practical ◀

▶ Fly the airplane ◀

On the ground :

Inform maintenance department.

End of procedure.

Intentionally left blank

3.9 - Electrical system**BAT AMP**

Indicates that battery current is over 50 A while on ground.

After starting the engine with airplane power, a battery charge over 50 amperes is normal.

▲ CAUTION ▲

Do not take off if battery charge is over 50 A.



If this indication remains steady at a high value :

It may be due to a battery or generation system failure.

End of procedure.

BAT OFF

Indicates that :

- *the SOURCE selector has been positioned on OFF or*
- *the battery plug is disconnected*

► Fly the airplane ◀

- | | | |
|-----|-----------------------|------|
| 1 - | SOURCE selector | OFF |
| 2 - | SOURCE selector | BATT |

If warning persists :

► Land as soon as possible ◀

- | | | |
|-----|------------------------------|---------|
| 3 - | Airplane mains voltage | Monitor |
|-----|------------------------------|---------|

End of procedure.

MAIN GEN

Indicates that GENERATOR selector has been positioned to OFF or ST-BY, or main generator is cut off.

- 1 - GENERATOR selector Check / Correct
If necessary
- If warning persists :*
- Main generator switching is confirmed.
- 2 - MAIN GENERATOR RESET push-button Press

In case of failure :

► Fly the airplane ◀

3 - Keep the following systems connected :

- Autopilot system
- Deicing systems
- STROBE and NAV lights
- Cockpit emergency lights
- VHF 1
- NAV/GPS 1
- BLEED
- LDG LIGHTS on short final

This will allow to keep electrical consumption below maximum standby capacity.

All other not necessary equipment can be disconnected.

4 - GENERATOR selector ST- BY

If necessary :

- 5 - ST-BY GENERATOR RESET push-button Press
- 6 - Maintain ST-BY loads below 100 A.

End of procedure.

LOW VOLTAGE

Normal functioning with GENERATOR selector on MAIN.

1 - Voltmeter voltages Check

If voltages are < 26 V :

2 - Monitor a possible voltage drop or any indication of battery discharge.

► Fly the airplane ◀

3 - Keep the following systems connected :

- Autopilot system
- Deicing systems
- STROBE and NAV lights
- Cockpit emergency lights
- VHF 1
- NAV/GPS 1
- BLEED
- LDG LIGHTS on short final

This will allow to keep electrical consumption
below maximum standby capacity.

All other not necessary equipment can be disconnected.

4 - GENERATOR selector ST- BY

If necessary :

5 - ST-BY GENERATOR RESET push-button Press

6 - Maintain ST-BY loads below 100 A.

End of procedure.

MAIN GEN and **LOW VOLTAGE** 1/3

With GENERATOR selector on ST-BY (after MAIN generator failure), functioning on ST-BY generator.

- 1 - GENERATOR selector MAIN
- 2 - MAIN GENERATOR RESET push-button Press

► Fly the airplane ◀

If MAIN GENERATOR successfully connected :

- 3 - Disconnect non-essential systems.
 - 4 - Voltmeter and ammeter Monitor
- Land as soon as possible ◀

End of procedure ■

If MAIN GENERATOR not successfully connected :

- 5 - GENERATOR selector ST-BY
- 6 - ST-BY GENERATOR RESET push-button Press

If ST-BY GENERATOR successfully connected :

- 7 - Disconnect non-essential systems.
 - 8 - Voltmeter and ammeter Monitor
- Land as soon as possible ◀

End of procedure ■

If ST-BY GENERATOR not successfully connected :

Both generators failure is confirmed.

Return to VMC conditions, if possible.

Continue ►

MAIN GEN and **LOW VOLTAGE**

2/3

► *Continuing*

9 - GENERATOR selector OFF

If altitude is > 10000 ft :

10 - OXYGEN switch ON

If VMC and non-icing conditions are possible :

11 - ESS BUS TIE switch EMER

The battery supplies only the ESS BUS and
BATT BUS in this configuration.

► Land as soon as possible ◀

If use of other than essential systems is required :

12 - ESS BUS TIE switch NORM

End of procedure ■*If VMC and non-icing conditions are not possible :*

13 - Manually disconnect systems as follows :

Breakers :

- PFD 2 Pull

- ADC 2 Pull

- TAS Pull

- DATA LINK Pull

- XPDR 2 Pull

Switches :

- AIRFRAME DE ICE OFF

- ICE LIGHT OFF

- PROP DE ICE OFF

- WINDSHIELD OFF

Continue ►

MAIN GEN and **LOW VOLTAGE** 3/3

► *Continuing*

- PITOT R & STALL HTR OFF
- OFF/LDG/TAXI light OFF
- PULSE OFF
- STROBE OFF
- BLEED OFF
- A/C OFF
- AUX BP OFF
- FUEL SEL MAN
- AP / TRIMS OFF
- DIMMER / CABIN / ACCESS OFF

If icing conditions :

- 14 - PITOT L HTR switch Check ON
- 15 - WINDSHIELD switch ON
- 16 - Maintain minimum recommended airspeeds into known icing conditions.

Flaps UP	> 135 KIAS
Flaps TO	> 115 KIAS
Flaps LDG	> 95 KIAS

If time permits :

- 17 - PLUGS breakers Pull
 - 18 - AIR COND breaker Pull
- Land as soon as possible ◀

End of procedure.

ELEC FEATH FAULT

Indicates a propeller feathering system malfunction.

▶ Fly the airplane ◀

- 1 - FEATHER breaker Pull
▶ Land as soon as possible ◀

End of procedure.



Bus bar 1/3

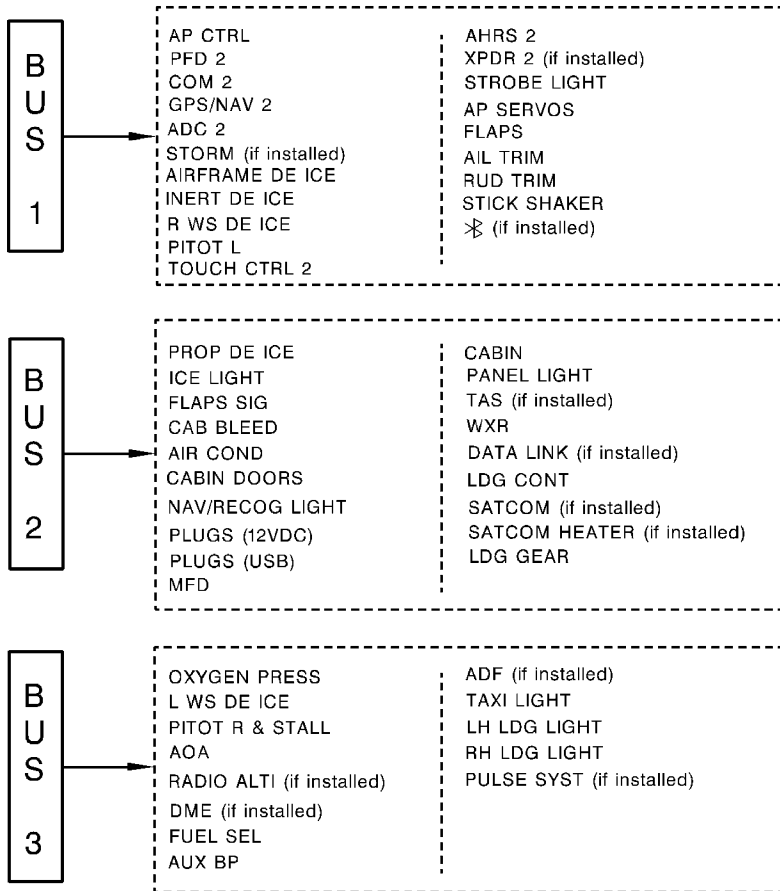

I4246000AAANMAB400

Figure 3.9.1 (1/3) - Electrical distribution of bus bars

Bus bar 2/3

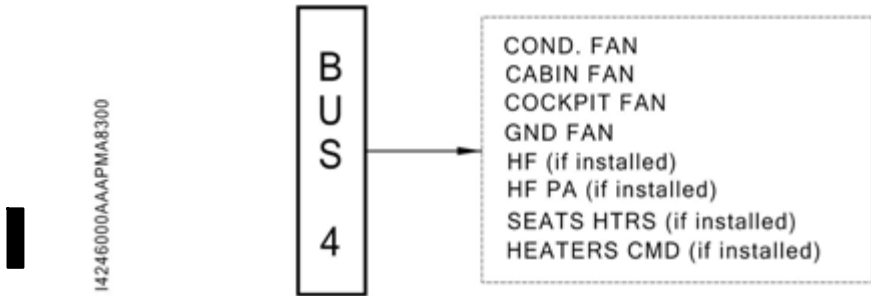

NOTE : BREAKERS ON C13 BIS FRAME

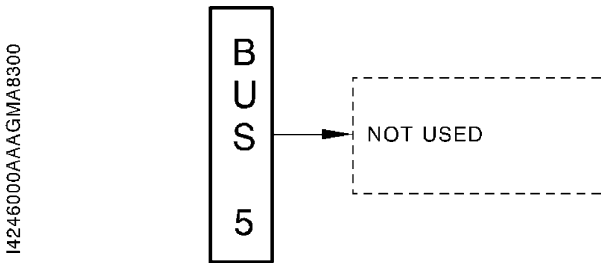
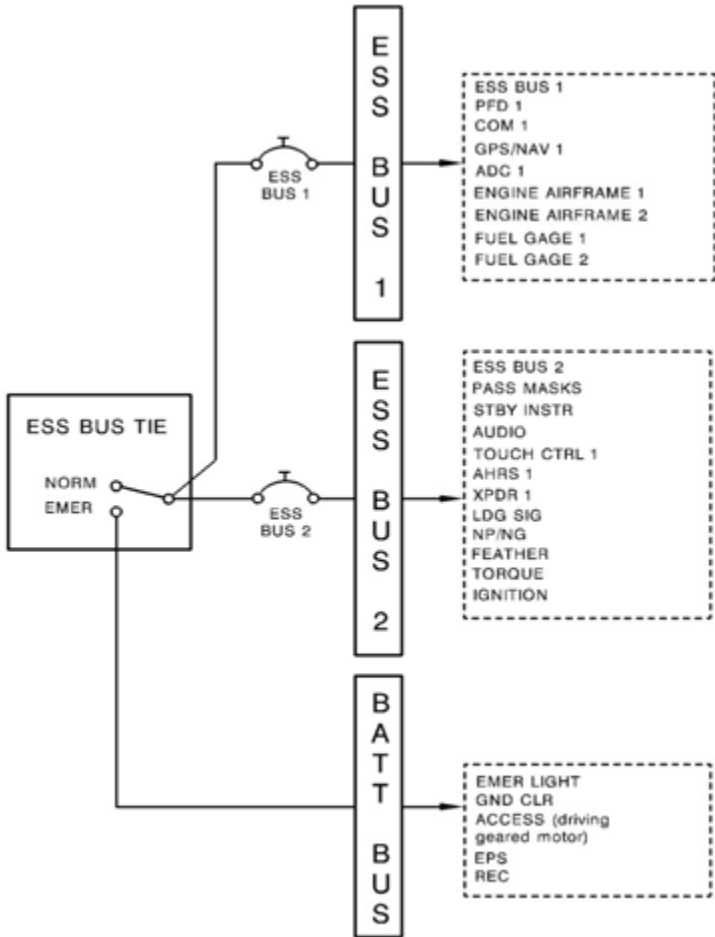

Figure 3.9.1 (2/3) - Electrical distribution of bus bars

Bus bar 3/3



H4246000AAAGMA18200

Figure 3.9.1 (3/3) - Electrical distribution of bus bars

Total loss of electrical power

- 1 - Maintain airplane control.
- 2 - Use the MD302 for
 - attitude,
 - airspeed and/or
 - altitude

► Fly the airplane ◀

► Land as soon as possible ◀

● NOTE ●

Airplane power is provided to the MD302 display for normal operation. Operation of the basic system is automatic. The system is powered ON while airplane power is ON.

■ If airplane power is lost, the internal battery will provide power to the MD302.

End of procedure.

Intentionally left blank

3.10 - Pressurization and air conditioning**PRESSU OFF**

1/2

Possibly due to :

- system malfunction
- BLEED switch on OFF position

If in flight :

- | | | |
|----------------------|--------------------|-----------------|
| 1 - | Oxygen masks | Use |
| 2 - | BLEED switch | Check / Correct |
| <i>If possible :</i> | | |
| 3 - | TRQ | Reduce |
| ▶ Fly the airplane ◀ | | |
| 4 - | BLEED switch | OFF |
| 5 - | BLEED switch | AUTO |

*If **PRESSU OFF** is still ON :**If altitude > 10000 ft :**If necessary :*

- 6 - Perform procedure Emergency descent
Refer to chapter 3.6

7 - Continue the flight.

● NOTE ●

If $Z_p > 10000 \text{ ft} \pm 500 \text{ ft}$, it may be followed by **CABIN ALTITUDE** and**USE OXYGEN MASK**

●

Inform maintenance department.

*End of procedure ■**Continue ▶*

PRESSU OFF 2/2

► *Continuing*

If on ground :

- 8 - BLEED switch OFF
 - 9 - Taxi back to apron.
 - 10 - Perform procedure Shutdown
Refer to chapter 4.3
- Inform maintenance department.

End of procedure.

GAS EVENT

Indicates a GASC system malfunction (only displayed 45 sec. after landing)

- 1 - Taxi back to the apron.
 - 2 - Perform procedure Shutdown
Refer to chapter 4.4
 - 3 - Inform maintenance department before next flight.
- End of procedure.*

GAS DEGRADED

Indicates a GASC system malfunction

- 1 - Shorten the flight.
- 2 - Inform maintenance department before next flight.

■ *End of procedure.*

PRESSU BACKUP

Indicates a GASC system malfunction. The GASC cannot compute optimal cabin altitude and is automatically set to 9800 ft default value as cabin altitude reference.

► Fly the airplane ◀

1 - Continue the flight.

Inform maintenance department before next flight.

▲ **CAUTION** ▲

When the airplane descends below 9800 ft, cabin descent rate coincides with airplane descent rate. The pilot should take into account the airplane descent profile in order to avoid pressure annoyance.



End of procedure.

CABIN ALTITUDE and **USE OXYGEN MASK**

• NOTE •

CABIN ALTITUDE is followed by **USE OXYGEN MASK** and 3 voice alerts
"Use oxygen mask / Use oxygen mask".

•

Indicates a cabin altitude over 10000 ft ± 500 ft.

- | | |
|---------------------------------------------------|-------|
| 1 - Pressurization indicator | Check |
| <i>If cabin altitude > 10000 ft ± 500 ft :</i> | |
| 2 - Oxygen masks | Use |

► Fly the airplane ◀

- 3 - BLEED switch Check AUTO
- 4 - DUMP switch Check NORM / Guarded
- 5 - EMERGENCY RAM AIR control knob Check pushed

If necessary :

- 6 - Perform procedure Emergency descent
Refer to chapter 3.6

- 7 - Limit flight altitude to maintain cabin altitude below 10000 ft.

■ Inform maintenance department before next flight.

End of procedure.

>> Without the EDM evolution patch (Pre-MOD70-0657-34) and prior to GDU v20.92 GARMIN software version (Pre-MOD70-0549-00E or F)

CABIN ALTITUDE and **USE OXYGEN MASK** and **EDM**

• NOTE •

CABIN ALTITUDE is followed by **USE OXYGEN MASK** and the “Use oxygen mask / Use oxygen mask” voice alert repeated three times.

EDM performs a 90° left heading change and a descent to 15000 ft.
EDM override is possible by pressing the AP / TRIM DISC push-button twice.
Then, other AP modes are usable.

Power reduction to accelerate the descent rate is recommended.

•

Indicates a cabin altitude over 10000 ft ± 500 ft.

- 1 - Pressurization indicator Check
- If cabin altitude is > 10000 ft ± 500 ft :*
- 2 - Oxygen masks Use

▶ Fly the airplane ◀

- 3 - BLEED switch Check AUTO
- 4 - DUMP switch Check NORM / Guarded
- 5 - EMERGENCY RAM AIR control knob Check pushed

If necessary :

- 6 - Perform procedure Emergency descent
Refer to chapter 3.6
- 7 - Limit flight altitude to maintain cabin altitude below 10000 ft.

Inform maintenance department before next flight.

End of procedure.

>> With the EDM evolution patch (Post-MOD70-0657-34) or after GDU v20.92
GARMIN software version (Post-MOD70-0549-00E or F)

EDM

• NOTE •

EDM may come on 45 seconds after **CABIN ALTITUDE** and

USE OXYGEN MASK.

EDM performs a 90° left heading change and a descent to 15000 ft.
EDM override is possible by pressing the AP / TRIM DISC push-button twice.
Then, other AP modes are usable.

Power reduction to accelerate the descent rate is recommended.

•

1 - Pressurization indicator Check

If cabin altitude is > 10000 ft ± 500 ft :

2 - Oxygen masks Use

▶ Fly the airplane ◀

3 - BLEED switch Check AUTO

4 - DUMP switch Check NORM / Guarded

5 - EMERGENCY RAM AIR control knob Check pushed

If necessary :

6 - Perform procedure Emergency descent
Refer to chapter 3.6

7 - Limit flight altitude to maintain cabin altitude below 10000 ft.

End of procedure.

CABIN DIFF PRESS

Indicates a cabin pressure differential over 6.4 PSI \pm 0.2 PSI.

1 - Pressurization indicator Check

If $\Delta P > 6.4 \text{ PSI} \pm 0.2 \text{ PSI}$:

2 - BLEED switch OFF

3 - Oxygen masks Use

► Fly the airplane ◀

If necessary :

4 - Perform procedure Emergency descent
Refer to chapter 3.6

End of procedure.

Cabin not depressurized after landing

If ΔP cabin remains > 0 :

- 1 - DUMP switch Actuate
- 2 - BLEED switch OFF

If necessary :

- 3 - EMERGENCY RAM AIR control knob Pull
- 4 - Wait for complete cabin depressurization before opening any door.

End of procedure.

O2 CYL CLOSED

Indicates that the oxygen cylinder isolation valve is closed.

▲ WARNING ▲

Flight is prohibited with oxygen cylinder closed.



1 - Oxygen cylinder Open

End of procedure.

DOOR

Indicates that one of the door latches of the door(s) is not correctly locked.

On ground :

- 1 - Check the correct locking, as well as the latches position of the door(s).

*If **DOOR** is still ON :*

- 2 - Do not take off.

End of procedure ■

In flight :

▶ Fly the airplane ◀

- 3 - Start a slow descent.
- 4 - Decrease cabin pressure differential By selecting a higher LFE
(LFE between 9500 ft and 10000 ft)

If a real failure of one of the doors is noticed :

- 5 - Oxygen masks Use
- 6 - BLEED switch OFF
- 7 - DUMP switch Actuate

If necessary :

- 8 - Perform procedure Emergency descent
Refer to chapter 3.6

End of procedure.

VACUUM LOW

Low vacuum may lead to malfunctioning of leading edge deicing and pressurization.

- 1 - Monitor the normal functioning of leading edge deicing and pressurization.

If necessary :

- 2 - Altitude Below 10000 ft
- 3 - Return to VMC conditions as soon as possible.

▶ Fly the airplane ◀
- 4 - BLEED switch OFF

End of procedure.

Defog malfunction

If moisture starts to quickly cover the inside of the windscreen with the HOT AIR FLOW distributor already turned to the left :

- 1 - HOT AIR FLOW distributor Set to around a 10 o'clock position

If moisture continues :

- 2 - HOT AIR FLOW distributor Turn to the left
- 3 - WINDSHIELD switch ON

If there is no improvement and if the flight safety is engaged :

- 4 - Altitude Around 10000 ft
- 5 - BLEED switch OFF

▲ CAUTION ▲

In flight, the cabin will quickly depressurize. Therefore, the cabin vertical speed indicator and altimeter indications will rapidly meet those of respectively the airplane VSI and altimeter.



End of procedure.

3.11 - Deicing system**Leading edges deicing failure**

Symptoms : failure on one of the two pneumatic deicing pulses :

- *ice on wing outboard sections,*
- *or, ice on wing inboard sections and stabilizers,*
- *one of the two cycling green lights is not lit.*

► Leave icing conditions as soon as possible ◀

1 - AIRFRAME DE ICE switch OFF

End of procedure.

PROP DEICE FAIL

Symptoms :

- propeller deicing green light is not lit,
- propeller vibrations.

1 - TRQ	Reduce
▶ Fly the airplane ◀	
2 - THROTTLE	Actuate
To vary RPM within operating range	

▶ Leave icing conditions as soon as possible ◀

End of procedure.

INERT SEP FAIL

Symptoms :

- **INERT SEP ON** does not appear within 50 seconds following INERT SEP switch setting ON,
- inertial separator is not retracted after 50 seconds following INERT SEP switch setting OFF,
- INERT DE ICE breaker triggered.

▶ Leave icing conditions as soon as possible ◀

▶ Fly the airplane ◀

End of procedure.

Windshield deicing failure

Symptoms :

- *windshield being covered uniformly by ice,*
- *no perception of heat when touching deiced section,*
- *windshield deicing green light is not lit.*

If symptoms result from overheat :

- 1 - WINDSHIELD switch OFF / ON
When necessary

In case of total failure :

- 2 - TEMP selector Max warm
- 3 - HOT AIR FLOW distributor Turn to the left

Before landing :

- 4 - Wait for a sufficient visibility.

End of procedure.

Windshield misting or internal icing

Symptoms : mist or ice on windshield internal face.

- 1 - TEMP selector Set to 12 o'clock position
- 2 - HOT AIR FLOW distributor Turn to the left
- 3 - WINDSHIELD switch ON

If unsuccessful, to get sufficient visibility :

- 4 - HOT AIR FLOW distributor Fully turn to the left
- 5 - Manually clean a sufficient visibility area.

If necessary :

▲ CAUTION ▲

In case of sideslip approach with pedal on the right during a long period, select R.H. fuel tank.



- 6 - Clean L.H. side window.
- 7 - Perform a sideslip approach with rudder pedals to the right.
To get sufficient landing visual references

For landing :

- 8 - FLAPS lever LDG
- 9 - Airspeed Maintain above 95 KIAS

End of procedure.

PITOT NO HT L-R

Indicates that :

- corresponding pitot tube heating has failed or
- PITOT L HTR switch or PITOT R & STALL HTR switch is not ON while the engine is running.

If **PITOT NO HT L** :

Icing conditions may alter airspeed indications provided by ADC1.

1 - Avoid icing conditions.

► Fly the airplane ◀

If not possible :

- 2 - Perform moderate descent or climb attitudes.

V_{MO} overshoot and stall warning system are always operating.

End of procedure ■

If **PITOT NO HT R** :

V_{MO} overshoot warning may be altered by icing conditions.

► Fly the airplane ◀

- 3 - Airspeed Monitor below 266 KIAS

End of procedure.

STALL NO HEAT

Indicates that :

- stall warning vane heating has failed or
- PITOT R & STALL HTR switch is not ON while the engine is running.

Correct operation of the aural stall warning may be altered by severe or prolonged icing.

- 1 - Airspeed Monitor
Maintain minimum airspeed according
to airplane configuration and icing conditions

► Fly the airplane ◀

End of procedure.

Intentionally left blank

3.12 - Miscellaneous**Trim Runaway**

▶ Fly the airplane ◀

1 - AP / TRIM DISC push-button Press and hold

The three trim tabs are disconnected and runaway stops.

2 - AP / TRIMS switch OFF**3 - AP / TRIM DISC push-button Release****4 - Pitch trim may be used manually.***If necessary :***5 - Airspeed Reduce**
To reduce control forces*In case of pitch trim runaway :***6 - AP / TRIMS switch AP OFF**

The pitch trim may be used manually, the two other trim tabs may be used again electrically.

End of procedure ■*In case of rudder or aileron trim runaway :***7 - RUD TRIM or AIL TRIM breaker Pull**
According to the defective trim**8 - AP / TRIMS switch ON**

The two other trim tabs may be used again electrically.

End of procedure.

Crack in cockpit window or window panel

► Fly the airplane ◀

- 1 - Descend slowly.
- 2 - Cabin ΔP Reduce
By setting Landing Field Elevation to 10000 ft

End of procedure.

Emergency exit use

- 1 - Check that the anti-theft safety pin has been removed.
- 2 - Lift up the opening handle.
- 3 - Pull emergency exit assembly towards oneself to release it from its recess.
- 4 - Put the emergency exit door inside fuselage or throw it away from the fuselage through the opening.
- 5 - Evacuate airplane.

End of procedure.

Emergency beacon (ELT) use

Before a forced landing :

If possible :

- 1 - Transmit a MAY DAY signal on COM VHF 121.5 MHz or on a known ATC frequency.

After landing :

- 2 - ELT remote control switch ON
Maintain ON until aid arrives

End of procedure.

Inadvertent spins

▲ WARNING ▲
Voluntary spins are prohibited.



- 1 - AP / TRIM DISC push-button Press and Hold until recovery
- 2 - Control wheel Neutral
Pitch and roll axis
- 3 - Rudder Fully opposed to the spin
- 4 - THROTTLE Flight IDLE
- 5 - FLAPS lever UP

When rotation is stopped :

- 6 - Level the wings and ease out of the dive.

► Fly the airplane ◀

End of procedure.

AP off, stall warning

• NOTE •

Shaker will vibrate simultaneously with stall warning aural alert.

•

1 - Fly the airplane, wings levelled and nose down until stall warning stops.

2 - TRQ As required

3 - Return to the desired flight path.

End of procedure.

USP ACTIVE

1 - Do not disconnect AP

2 - Increase power up to 50 % minimum

3 - Manage the flight

• NOTE •

Stall warning may be triggered but AP will remain ON

•

End of procedure.

AURAL WRN FAIL

Indicates that no aural warning alerts are available.

▲ CAUTION ▲

No aural stall warning.

No aural overspeed warning.

No landing gear warning.



1 - Maintain airspeeds

Flaps UP	105 < KIAS < 266
Flaps TO	100 < KIAS < 178
Flaps LDG	85 < KIAS < 122

End of procedure.

AURAL WRN 1 CHNL

• NOTE •

System switches automatically on the remaining valid aural channel.

•

End of procedure.

ESP FAIL

- Indicates pitch, roll, high speed and AoA protections are inoperative.

► Fly the airplane ◀

1 - Maintain the airplane inside the flight envelope.

Flaps UP	105 < KIAS < 266
Flaps TO	100 < KIAS < 178
Flaps LDG	85 < KIAS < 122

- 2 - Continue flight.
- 3 - Inform maintenance department.

End of procedure.

ESP DEGRADED - IAS

■ *Indicates high speed protection is inoperative.*

▶ Fly the airplane ◀

1 - Maintain IAS below 266 KIAS.

2 - Continue flight.

3 - Inform maintenance department.

End of procedure.

ESP DEGRADED - AOA

- Indicates AoA protection at low speed is inoperative.

► Fly the airplane ◀

- 1 - Maintain airspeed above 1.3Vs.

Flaps UP	105 < KIAS < 266
Flaps TO	100 < KIAS < 178
Flaps LDG	85 < KIAS < 122

- 2 - Continue flight.
- 3 - Inform maintenance department.

End of procedure.

Oxygen use 1/2

With or without **USE OXYGEN MASK**.

▲ WARNING ▲

**Smoking is strictly prohibited when the oxygen system is in use.
Before using oxygen, remove any trace of oil, grease, soap and other
fatty substances (including lipstick, make-up, etc...).**



For front seats :

- 1 - Take a mask above the opposite seat (pilot : right-side mask ; front passenger : left-side mask).
- Pull the mask out of the stowage cup and fully uncoil the tube.
- Press the red side vanes together to inflate the harness.
- Put the mask on the face and release the red side vanes.

If there is no smoke in cabin :

- 2 - Mask regulator control tab N (Normal)
100 % as required
- 3 - Vent valve Closed

If there is smoke in cabin :

- 4 - Mask regulator control tab 100 %
- 5 - EMERGENCY control knob EMERGENCY
- 6 - Smoke goggles Don and fit to the mask
- 7 - Vent valve Open
- 8 - Oxygen flow indicator on mask hose Check
- 9 - MICRO/MASK switch MASK
- 10 - PASSENGER OXYGEN switch DEPLOY
- 11 - Perform an emergency descent To the minimum
enroute altitude

Continue ►

Oxygen use

2/2

► *Continuing**If possible :*

- 12 - Perform an emergency descent To an altitude
below 10000 ft

For intermediate and rear seats :

- 1 - Take a mask.
- 2 - Fully uncoil the tube.
- 3 - Pull on the lanyard cord to pull out the lanyard pin and flow the oxygen.
- 4 - Put the mask on the face.
- 5 - Check that the green bag inflates.

End of procedure.

Airspeed indicating system failure

Symptoms : erroneous indication in flight.

- 1 - PITOT L HTR switch Check ON
- 2 - PITOT R & STALL HTR switch Check ON

If symptoms persist :

- 3 - ALTERNATE STATIC SOURCE selector Pull thoroughly
- 4 - Use standby instrument only.

If symptoms persist, as well as on the electronic standby instrument on the L.H instrument panel :

- 5 - Perform a precautionary approach maintaining an adequate airspeed.

End of procedure.

Flight into severe icing conditions

Severe icing conditions, particularly freezing rain and freezing drizzle, can be identified by :

- *unusually extensive ice accumulation on the airframe and windshield in areas not normally observed to collect ice,*
- *accumulation of ice on the upper surface of the wing aft of the protected area.*

Procedures for exiting freezing rain or freezing drizzle conditions :

- 1 - Inform ATC to exit severe icing conditions by changing the route or the altitude.
- 2 - Avoid any sudden maneuver on flight controls.

▶ Do not engage the autopilot ◀

If the autopilot is engaged :

- 3 - Hold the control wheel firmly and disengage the autopilot.

If an unusual roll response or uncommanded roll control movement is observed :

- 4 - Angle of Attack Reduce

▶ Do not extend flaps when holding in icing conditions ◀

Operation with extended flaps can result in a reduced wing Angle of Attack, with the possibility of ice forming on the upper surface further aft on the wing than normal, possibly aft of the protected area.

If the flaps are extended :

- 5 - Do not retract them until the airframe is clear of ice.

End of procedure.

CARGO DOOR

Indicates that front cargo door is open.

On ground :

- 1 - Check and close the door.

In flight :

▶ Fly the airplane ◀

- 2 - Airspeed Reduce
To minimum available

▶ Land as soon as practical ◀

End of procedure.

GPU DOOR

Indicates that GPU door is open.

On ground :

- 1 - Check and close the door.

In flight :

► Fly the airplane ◀

- 2 - Airspeed Reduce
To minimum available

► Land as soon as practical ◀

End of procedure.

IGNITION

Indicates that ignition exciter is running.

1 - IGNITION switch Check position

If weather permits :

2 - IGNITION switch AUTO

▶ Fly the airplane ◀

● NOTE ●

IGNITION switch may be left ON for a long period.

●

End of procedure.

AP ON YD OFF

Indicates that the autopilot is ON while Yaw Damper is OFF, so no automatic rudder trim is available.

1 - Yaw Damper status Check

If necessary :

2 - Yaw Damper status Correct

End of procedure.

Autopilot or electric pitch trim malfunction

▲ CAUTION ▲

When disconnecting the autopilot after a pitch trim malfunction, hold the control wheel firmly. Up to 30 pounds of force on the control wheel may be necessary to hold the airplane level.



- 1 - AP / TRIM DISC push-button Press and hold
- 2 - AP / TRIMS switch OFF
- 3 - AP / TRIM DISC push-button Release

If necessary :

- 4 - Control wheel Retrim

End of procedure.

Dual GPS/SBAS failure

(**DR** or **LOI** annunciation on HSI)

1/2

Loss of GPS/SBAS navigation data

When both GPS/SBAS receivers are inoperative or GPS navigation information is not available or invalid, the GARMIN system will enter one of two modes : Dead Reckoning mode (DR) or Loss Of Integrity mode (LOI). The mode is indicated on the HSI by an amber DR or LOI.

Which mode is active depends on the distance from the destination airport in the active flight plan.

If the LOI annunciation is displayed, revert to an alternate means of navigation appropriate to the route and phase of flight.

In Dead Reckoning mode, the MAP – NAVIGATION MAP will continue to be displayed with a ghosted airplane icon in the center and an amber 'DR' overwriting the icon. Airplane position will be based upon the last valid GPS position, then estimated by Dead Reckoning methods. Changes in true airspeed, altitude, or winds aloft can affect the estimated position substantially. Dead Reckoning is only available in Enroute mode; Terminal and Approach modes do not support DR. Course deviation information will be displayed as an amber CDI on both PFDs and will remain for up to 20 minutes after GPS position data has been lost. The autopilot and/or flight director may be coupled in GPS mode while the system is in Dead Reckoning mode.

Refer to the GARMIN Pilot's Guide for further information.

Revert to an alternate means of navigation appropriate to the route and phase of flight.

If alternate navigation sources (ILS, LOC, VOR, DME, ADF) are available :

1 - Navigation Use alternate sources

Continue ►

Dual GPS/SBAS failure
(DR or LOI annunciation on HSI) 2/2

► *Continuing*

If no alternate navigation sources are available :

Dead Reckoning (DR) Mode - Active when the airplane is greater than 30 NM from the destination airport :

- 1 - Navigation Use the airplane symbol, magenta course line on the map display and the amber CDI for course information

● NOTE ●

All information normally derived from GPS turns amber. All of this information will become less accurate over time.

TAWs is inoperative.

DR mode uses heading, true airspeed, last known wind data, and the last known GPS position to estimate the airplane's current position. DR information will be available for a maximum of 20 minutes.

MAP – TRAFFIC MAP display is not dependent on GPS information.

The position of displayed traffic relative to the airplane symbol on the map is still accurate.



Loss Of Integrity (LOI) Mode - Active when the airplane is within 30 NM of departure airport (as calculated from the previous GPS or DR position)

- 1 - Navigation Fly towards known visual conditions, use ATC or other information sources as possible

● NOTE ●

All information derived from GPS or DR will be removed from the displays.

TAWs is inoperative.

The airplane symbol is removed from all maps. The map will remain centered at the last known position. NO GPS POSITION will be annunciated in the center of the map.



End of procedure.

ABORT APR

Indicates a loss of GPS navigation.

▶ Perform a go-around◀

End of procedure.

APR DWNGRADE

Indicates that the GARMIN system downgrades the approach upon navigation system integrity failure during a GPS LPV, LNAV/VNAV.

This may be also indicated by an annunciation change on the HSI.

- 1 - System will automatically downgrade to LNAV/VNAV or LNAV.
- 2 - Update minimums as appropriate.

• NOTE •

In some cases, the approach may be downgraded without **APR DWNGRADE** being displayed to the crew. Please consider the HSI approach annunciation as the primary mean to identify the current mode of operation.

•

• NOTE •

Refer to the section 7 to get details on the approach downgrading process.

•

End of procedure.

PIT in AP vertical mode during FD approach with vertical guidance

*Indicates the loss of vertical integrity signal during LPV or LNAV/VNAV.
This may be indicated by an annunciation change on the HSI.*

Symptoms :

- AP mode from GP flashing 5 seconds to **PIT**
- VDI is flagged and indicates NO GP

► Fly the airplane ◀

Actions

If automatic downgrade to LNAV :

- 1 - Update minimums as appropriate.

If not :

- Perform a go-around ◀

End of procedure.

VDI or **VDI** on Approach

Symptoms :

- *VDI amber or VDI white at bottom of VDI window.*

▶ *Fly the airplane* ◀

If possible :

- 1 - Use LNAV minimums.

If not :

- ▶ Perform a go-around◀

End of procedure.

Left PFD failure

▶ Fly the airplane ◀

At takeoff :

- 1 - Fly the airplane manually Using stand-by instruments
- 2 - AP / TRIM DISC push-button Press
To mute aural tone

In flight :

▲ CAUTION ▲

In case of ILS approach, don't forget to select LOC2 on CDI source.

Use of reversionary mode will report left PFD information on MFD and disable supplementary functions as stormscope,...



- 3 - Fly the airplane manually Using stand-by instruments
- 4 - AP / TRIM DISC push-button Press
To mute aural tone
- 5 - DISPLAY BACKUP mode Engage on PFD2
Pressurization switches to PRESSU BACKUP,
with **PRESSU BACKUP**
- 6 - PFD 1 breaker Check pushed
- 7 - XFR button (on AFCS) Press / to right side
- 8 - Autopilot Use normally

Following systems are lost :

- COM 1, NAV 1, DME 1, XPDR 1
- Radio altimeter, TAS, if installed

▶ Land as soon as possible ◀

- 9 - COM 2, NAV 2, DME 2, XPDR 2 Use
- 10 - COM 2 MIC Select

End of procedure.

AHRS failure	1/2
--------------	-----

Symptoms : Autopilot is disconnected

- On PFD(s) : Comparator window

HDG and/or **PIT** and/or **ROL** annunciation(s)

- On PFD(s) : Reversionary sensor window

BOTH ON AHRS1 or **BOTH ON AHRS2** annunciation

Lost systems :

- AHRS1 or AHRS2
- Autopilot (AP)

Systems still operative :

- Flight Director (FD), when engaged again.

Actions :

Autopilot is not operative.

- 1 - AHRS1 and/or AHRS2 breaker Check pushed

If **BOTH ON AHRS1** or **BOTH ON AHRS2** annunciation is associated to

HDG and/or **PIT** and/or **ROL** annunciation(s) :

- 2 - Fly the airplane manually.

If pilot wishes :

- 3 - FD default mode Engage
PIT and ROL

- 4 - FD specific modes Engaged as desired
HDG, NAV, ALT, ...

- 5 - Fly the airplane manually to follow Command Bars.

End of procedure ■

Continue ►

AHRS failure

2/2

► *Continuing*

If all annunciations **HDG** and/or **PIT** and/or **ROL** go off, refer to following condition.

If **BOTH ON AHRS1** or **BOTH ON AHRS2** annunciation not associated to

HDG and/or **PIT** and/or **ROL** annunciation(s) :

- 6 - PFD1 and PFD2 SENSOR softkeys Press
- 7 - AHRS1 on PFD1 and/or AHRS2 on PFD2 Reset
- 8 - **BOTH ON AHRS1** or **BOTH ON AHRS2** annunciation Check OFF
- 9 - Autopilot Use normally
As desired

End of procedure.

ADC failure

Symptoms :

- On PFD(s) : Comparator window

IAS and/or **ALT** annunciation(s)

- On PFD(s) : Reversionary sensor window

BOTH ON ADC1 or **BOTH ON ADC2** annunciation

Lost systems :

- ADC1 or ADC2

Actions :

Autopilot is still operative.

- 1 - ADC 1 and/or ADC 2 breaker Check pushed

If **BOTH ON ADC1** or **BOTH ON ADC2** annunciation
is associated to **IAS** and/or **ALT** annunciation(s)

- 2 - No action required.

End of procedure ■

If all annunciations **IAS** , **ALT** go off, refer to following condition.

If **BOTH ON ADC1** or **BOTH ON ADC2** annunciation
not associated to **IAS** and/or **ALT** annunciation(s)

- 3 - PFD1 and PFD2 SENSOR softkeys Press
- 4 - ADC1 on PFD1 and/or ADC2 on PFD2 Reset

- 5 - **BOTH ON ADC1** or **BOTH ON ADC2**
annunciation Check OFF

End of procedure.

MFD failure

• NOTE •

If PFD2 is in fullscreen mode, it will be splitted a few seconds after MFD failure.

•

Lost system :

- MFD

Actions :

- 1 - L.H. DISPLAY BACKUP button Press
- 2 - MFD breaker Check pushed

End of procedure.

XPDR1 FAIL or **XPDR2 FAIL**

Indicates transponder 1 [or transponder 2] is inoperative.

▶ Fly the airplane ◀

If transponder 2 [or transponder 1] is available :

- 1 - Set transponder 2 [or transponder 1] as active.
- 2 - Continue flight.
- 3 - Inform maintenance department.

If transponder 2 [or transponder 1] is unavailable :

- 4 - Inform Air Traffic Control of the loss of the second transponder.
- 5 - Leave controlled airspace.
- 6 - Continue flight.
- 7 - Inform maintenance department.

End of procedure.

XPDR1 ADS-B FAIL or **XPDR2 ADS-B FAIL**

Indicates ADS-B OUT function of transponder 1 [or transponder 2] is inoperative. Other functions may remain available.

► Fly the airplane ◀

If transponder 2 [or transponder 1] is available :

- 1 - Restore ADS-B OUT function by setting transponder 2 [or transponder 1] as active.
- 2 - Continue flight.
- 3 - Inform maintenance department

If transponder 2 [or transponder 1] is unavailable :

- 4 - Inform Air Traffic Control.
- 5 - Leave ADS-B OUT airspace.
- 6 - Continue flight.
- 7 - Inform maintenance department.

End of procedure.

GWX FAIL

Indicates that GWX weather radar is inoperative.

• NOTE •

No real time weather data available

•

▶ Fly the airplane ◀

- 1 - WXR breaker Check pushed
- 2 - Continue flight by using other weather data source, and adjust flight route.
- 3 - Inform maintenance department.

End of procedure.

TCAS FAIL

Indicates that Traffic Advisory System is inoperative.

• NOTE •

No active traffic available, but ASDB-IN traffic may still be displayed.

•

► Fly the airplane ◀

1 - Inform maintenance department.

End of procedure.

TRAFFIC FAIL

Indicates that Traffic Advisory System is inoperative.

• NOTE •

No active traffic available, but ASDB-IN traffic may still be displayed.

•

▶ Fly the airplane ◀

1 - Inform maintenance department.

End of procedure.

Section 4

Normal procedures

Table of contents

4.1	-	General	4.1.1
4.2	-	Airspeeds for normal operation	4.2.1
4.3	-	Check-list procedures	4.3.1
		Inside inspection	4.3.1
		Before starting engine	4.3.3
		Motoring (if residual ITT > 150°C)	4.3.4
		Engine start	4.3.5
		After engine start with GPU	4.3.6
		After engine start	4.3.6
		Before taxiing	4.3.7
		Before line up	4.3.8
		Normal takeoff	4.3.9
		Short takeoff	4.3.10
		After takeoff	4.3.11
		Climb	4.3.12
		Cruise	4.3.13
		Before descent	4.3.14
		Approach	4.3.15
		Final approach (in GS) or downwind leg (VMC)	4.3.16
		Short final (≈ 500 ft)	4.3.17
		Runway clear	4.3.18
		Shutdown	4.3.19
4.4	-	Amplified procedures	4.4.1
		Preflight inspection	4.4.1
		Inside inspection	4.4.17
		Before starting engine	4.4.21
		Engine start	4.4.24
		Motoring	4.4.27
		Motoring followed by an engine start	4.4.30
		After engine start with GPU	4.4.33
		After engine start	4.4.34
		In-flight available oxygen quantity	4.4.36

	Before taxiing	4.4.37
	Taxiing	4.4.41
	Before line up	4.4.42
	Normal takeoff	4.4.46
	Short takeoff	4.4.48
	After takeoff	4.4.51
	Climb	4.4.52
	Cruise	4.4.54
	Before descent	4.4.56
	Approach	4.4.57
	Final approach (in GS) or downwind leg (VMC)	4.4.58
	Short final (≈ 500 ft)	4.4.59
	Landing	4.4.60
	Go-around with AP OFF	4.4.61
	Go-around with AP ON	4.4.63
	Touch and go	4.4.64
	Runway clear	4.4.66
	Shutdown	4.4.67
	Outside check after shutdown	4.4.70
4.5	- Particular procedures	4.5.1
	Flight into known icing conditions	4.5.1
	Flight into severe icing conditions	4.5.6
	Flight under heavy precipitations	4.5.7
	Utilization on runways covered with water	4.5.7
	Utilization on runways covered with melting or not tamped snow	4.5.8
	Utilization on icy or covered with tamped snow runways	4.5.11
	Utilization by cold weather (0°C to - 25°C) and very cold weather (- 25°C to - 40°C)	4.5.13
	Utilization by cold weather (- 0°C to - 25°C) and very cold weather (- 25°C to - 40°C) - Envelope 1	4.5.14
	Utilization by cold weather (- 0°C to - 25°C) and very cold weather (- 25°C to - 40°C) - Envelope 2	4.5.17
	Utilization by cold weather (- 0°C to - 25°C) and very cold weather (- 25°C to - 40°C) - Envelope 3	4.5.22
	Landing procedure with strong headwind or crosswind	4.5.24
	Utilization on grass runway	4.5.26
	GPS navigation	4.5.28

4.1 - General

This section provides procedures for the conduct of normal operation of TBM airplane.

The first part of this section lists the normal procedures required as a check list.

The amplified procedures are developed in the second part of the section.

The normal procedures for optional systems are given in section 9, Supplements of the POH.

Intentionally left blank

4.2 - Airspeeds for normal operation

Conditions :

- Takeoff weight : 7394 lbs (3354 kg)
- Landing weight : 7024 lbs (3186 kg)

Rotation airspeed (V_R) :		
- Flaps TO	90 KIAS	
Best rate of climb speed (V_Y) :		
- Landing gear and flaps UP	124 KIAS	
Best angle of climb speed (V_X) :		
- Landing gear and flaps UP	100 KIAS	
Maximum speed :		
- Flaps TO	178 KIAS	
- Flaps LDG	122 KIAS	
Maximum airspeed with landing gear down		178 KIAS
Maximum landing gear operating airspeeds		
- Extension	178 KIAS	
- Retraction	150 KIAS	
Approach airspeed :		
- Flaps LDG	85 KIAS	
Maximum operating speed (V_{MO})		266 KIAS
Glide speed (maximum L / D ratio)		
- Landing gear and flaps UP	120 KIAS	

Intentionally left blank

4.3 - Check-list procedures

Initial inside inspection and outside inspection performed.
OXYGEN cylinder open.

Inside inspection

1/2

- 1 - Cabin door and pilot door, if installed Closed / Locked
- 2 - Baggage Stowed
- 3 - EMERGENCY EXIT pin Removed
- 4 - Seat, pedals, harness Adjust / Lock
- 5 - PASSENGER OXYGEN STBY
- 6 - OXYGEN ON
- 7 - Crew oxygen masks Test
- 8 - EXT LIGHTS All OFF
- 9 - INT LIGHTS All OFF
- 10 - Crash lever Down
- 11 - STARTER OFF
- 12 - IGNITION AUTO
- 13 - AUX BP OFF
- 14 - FUEL SEL MAN
- 15 - AP / TRIMS OFF
- 16 - A/C OFF

■ >> *Airplane with seats heaters system (Post-MOD70-0588-25)*

- 17 - SEATS HTRS MASTER OFF

■ >> *All*

- 18 - CB LIGHTS OFF
- 19 - MICRO / MASK MICRO / Guarded
- 20 - DE ICE SYSTEM All OFF

Continue ►

Inside inspection	2/2
-------------------	-----

► *Continuing*

- 21 - INERT SEP OFF
- 22 - PARK BRAKE Reset / ON
- 23 - LANDING GEAR DN
- 24 - DUMP NORM / Guarded
- 25 - BLEED OFF
- 26 - HOT AIR FLOW Fully turned to the right
- 27 - MAN OVRD Full backward (notched)
- 28 - THROTTLE CUT OFF
- 29 - FUEL TANK SELECTOR Open / L or R
- 30 - ALTERNATE STATIC SOURCE Pushed
- 31 - EMERGENCY RAM AIR Pushed
- 32 - ESS BUS TIE NORM / Guarded
- 33 - Breakers All pushed
- 34 - Landing gear emergency pump handle Check

End of procedure.

Before starting engine

- 1 - Crash lever Up
- 2 - ATIS Copied
- 3 - Start clearance As required
- 4 - SOURCE BATT or GPU
- 5 - GENERATOR MAIN
- 6 - TEST Press
- 7 - LANDING GEAR LIGHTS / CHECK DOWN Test
- 8 - MFD Initialize
- 9 - Fuel on board Check
- 10 - Residual ITT Check

If residual ITT > 150°C :

- 11 - Perform procedure Motoring
Refer to procedure hereafter
- 12 - VOLTS : BATT > 24.5 V / GPU ~ 28 V Check
- 13 - CAS Check

End of procedure.

Motoring (if residual ITT > 150°C)

- 1 - IGNITION OFF
- 2 - AUX BP ON
- 3 - **AUX BOOST PMP ON** Check ON
- 4 - Propeller area Clear
- 5 - STARTER ON
2 sec then OFF

After 30 seconds maximum :

- 6 - STARTER ABORT
Then OFF
- 7 - AUX BP OFF

End of procedure.

Engine start

▲ **CAUTION** ▲

After aborted engine starts, wait :
1 min / 5 min / 30 min before 2nd / 3rd / 4th new engine start.



- 1 - IGNITION AUTO
- 2 - AUX BP ON
- 3 - **AUX BOOST PMP ON** Check ON
- 4 - Propeller area Clear
- 5 - STARTER ON
2 sec then OFF

When Ng around 13 % :

- 6 - THROTTLE LO-IDLE
- 7 - ITT, Ng, OIL °C and OIL PSI Monitor

ITT	Maximum 1000°C for 5 sec 870°C for 20 sec
Ng	30 % before 30 sec 50 % before 1 min

When

- Ng > 50 % and,
- 1 minute max :
- 8 - Starter Check OFF automatically
End of procedure.

After engine start with GPU

- 1 - SOURCE BATT
- 2 - GPU Disconnect
- 3 - **GPU DOOR** Check OFF

End of procedure.

After engine start

- 1 - THROTTLE LO-IDLE ►Flight IDLE
- 2 - Ng Check 70 % ± 2 %
- 3 - OIL °C and OIL PSI Check
- 4 - AUX BP AUTO
- 5 - FUEL SEL AUTO
- 6 - SHIFT Test
- 7 - AP / TRIMS ON

If BATT < 80 amps :

- 8 - GENERATOR ST-BY / Test
- 9 - GENERATOR MAIN
- 10 - CAS Check
- 11 - A/C As required

■ >> *Airplane with seats heaters system (Post-MOD70-0588-25)*

- 12 - SEATS HTRS MASTER As required

■ >> *All*

- 13 - BLEED AUTO or MAX DIFF

End of procedure.

Before taxiing

- 1 - Stand-by instruments Check
- 2 - DE ICE SYSTEM Test
- 3 - INERT SEP ON
- 4 - Flight controls Check
- 5 - TRIMS Test
- 6 - FLAPS UP
- 7 - MFD
 - FPL Set
 - LFE Set / Check
 - WX RADAR STBY
- 8 - THROTTLE Feather twice
- 9 - EIS Check
- 10 - CAS Check
- 11 - TAXI lights ON

End of procedure.

Before line up

- 1 - LDG lights ON
- 2 - NAV ON
- 3 - STROBE ON
- 4 - IGNITION As required
AUTO or ON
- 5 - AUX BP AUTO
- 6 - FUEL SEL AUTO
- 7 - DE ICE SYSTEM As required
- 8 - PITOT L HTR / PITOT R & STALL HTR ON
- 9 - INERT SEP ON
- 10 - TRIMS TO
- 11 - FLAPS TO
- 12 - A/C As required
- 13 - BLEED AUTO or MAX DIFF
- 14 - LFE Check
- 15 - FUEL gages Check imbalance
- 16 - BATT Check below **50 amps**
- 17 - EIS Check
- 18 - CAS Check
- 19 - Altimeters setting As required
- 20 - Instruments departure setting Check
- 21 - SID (PROC) Set
- 22 - ALT SEL Set
- 23 - XPDR squawk Set

End of procedure.

Normal takeoff

- 1 - ADI, HSI, headings Check
- 2 - PROP RPM Green sector
- 3 - Brakes Release
- 4 - TRQ 100 %
- 5 - Rotation airspeed

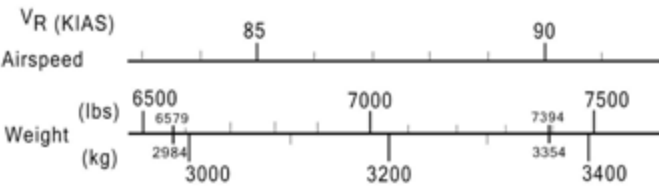
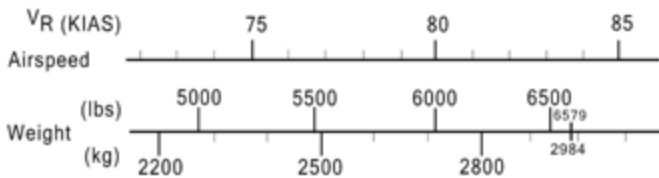

14010000AAAIMA8000

- 6 - Attitude 10° Up

When vertical speed is positive :

- 7 - Brakes Apply
- 8 - LANDING GEAR UP

When airspeed above 115 KIAS :

- 9 - FLAPS UP

End of procedure.

Short takeoff

- 1 - ADI, HSI, headings Check
- 2 - PROP RPM Green sector
- 3 - TRQ 100 %
- 4 - Brakes Release
- 5 - Rotation airspeed

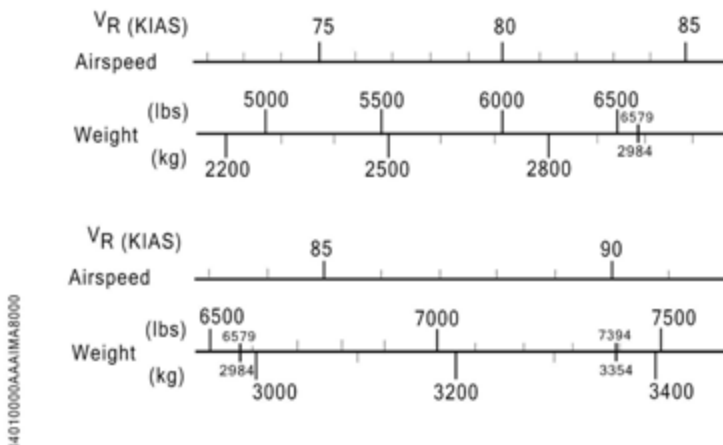

Weight < 6579 lbs (2984 kg) :

- 6 - Attitude 15° Up

Weight > 6579 lbs (2984 kg) :

- 7 - Attitude 12.5° Up

When vertical speed is positive :

- 8 - Brakes Apply
- 9 - LANDING GEAR UP

When airspeed above 115 KIAS :

- 10 - FLAPS UP

End of procedure.

After takeoff

- 1 - LANDING GEAR Check UP
- 2 - FLAPS Check UP
- 3 - TRQ Check max 100 %
- 4 - EIS Check
- 5 - CAS Check
- 6 - DE ICE SYSTEM As required
- 7 - INERT SEP As required

End of procedure.

Climb

- 1 - ALT SEL Check
- 2 - Altimeters setting As required
- 3 - Autopilot Check
- 4 - TRQ adjustment / ITT / Ng Check
- 5 - EIS Check
- 6 - CAS Check
- 7 - WX RADAR As required
- 8 - Pressurization Check
- 9 - FUEL gages Check
- 10 - AMPS / VOLTS Check
- 11 - DE ICE SYSTEM As required
- 12 - INERT SEP As required
- 13 - LDG lights As required

End of procedure.

Cruise

- | | | |
|------|---------------------------------|-------------|
| 1 - | Altimeters setting | Check |
| 2 - | Autopilot | Check |
| 3 - | TRQ adjustment / ITT / Ng | Check |
| 4 - | EIS | Check |
| 5 - | CAS | Check |
| 6 - | Pressurization | Check |
| 7 - | FUEL gages | Check |
| 8 - | AMPS / VOLTS | Check |
| 9 - | DE ICE SYSTEM | As required |
| 10 - | INERT SEP | As required |
| 11 - | LDG lights | OFF |
| 12 - | Top of descent | Computed |

End of procedure.

Before descent

- 1 - Briefing before approach Completed
- 2 - Altimeters setting Check
- 3 - Pressurization Check
- 4 - LFE Check
- 5 - FUEL gages Check
- 6 - AMPS / VOLTS Check
- 7 - DE ICE SYSTEM As required
- 8 - INERT SEP As required

End of procedure.

Approach

- | | | |
|-----|--------------------------------|-------------|
| 1 - | Altimeters setting (QNH) | Set / Check |
| 2 - | Minimums | Set / Check |
| 3 - | COM / NAV / GPS | Set / Check |
| 4 - | Pressurization | Check |
| 5 - | LFE | Check |
| 6 - | FUEL gages | Check |
| 7 - | AMPS / VOLTS | Check |
| 8 - | DE ICE SYSTEM | As required |
| 9 - | INERT SEP | ON |

Below FL 100 :

- | | | |
|------|------------------|----|
| 10 - | LDG lights | ON |
|------|------------------|----|

End of procedure.

Final approach (in GS) or downwind leg (VMC)

- 1 - LDG lights ON
- 2 - LANDING GEAR DN
Check 3 green
- 3 - FLAPS TO

End of procedure.

Short final (\approx 500 ft)

- 1 - LANDING GEAR Check
DN and 3 green
 - 2 - FLAPS LDG
 - 3 - AP / YD Disconnect
- End of procedure.*

Runway clear

- 1 - TAXI light ON
- 2 - NAV As required
- 3 - STROBE As required
- 4 - DE ICE SYSTEM As required
- 5 - TRIMS Reset to TO
- 6 - FLAPS UP
- 7 - A/C As required
- 8 - XPDR Check
- 9 - WX RADAR Check

End of procedure.

Shutdown

1/2

- 1 - PARK BRAKE Set / ON
- 2 - EXT LIGHTS All OFF
- 3 - INT LIGHTS As required
- 4 - OXYGEN OFF
- 5 - FUEL SEL MAN
- 6 - AP / TRIMS OFF
- 7 - A/C OFF

>> *Airplane with seats heaters system (Post-MOD70-0588-25)*

- 8 - SEATS HTRS MASTER OFF

>> *All*

- 9 - BLEED OFF
- 10 - THROTTLE Flight IDLE
For 2 min
- 11 - THROTTLE LO-IDLE
For 15 sec
- 12 - THROTTLE CUT OFF
- 13 - INERT SEP OFF
- 14 - **AUX BOOST PMP ON** Check ON
- 15 - AUX BP OFF
- 16 - GENERATOR OFF

When inertial separator is retracted, after approximately 40 sec :

- 17 - SOURCE OFF
- 18 - Crash lever Pull down
- 19 - Stand-by instruments OFF

Continue ►

Shutdown	2/2
----------	-----

► *Continuing*

20 - Oxygen cylinder (right wing fairing) Close

21 - Install air inlet and static port plugs, and exhaust and pitot covers.

• NOTE •

Be careful of exhaust stubs temperature before installing covers.

•

• NOTE •

15 to 20 minutes after the engine shutdown, check engine oil level.

Refer to chapter 8.7 : Oil level check.

•

End of procedure.

4.4 - Amplified procedures

Preflight inspection

1/16

The preflight inspection procedure is based on a scanning method.

It is divided in 6 subparts to cover all items of the preflight - see figure 4.4.1

- I Initial inside inspection
- II Cabin
- III L.H. Wing
- IV Fuselage forward section
- V R.H. Wing
- VI Fuselage rear section / Empennages

▲ WARNING ▲

During outside inspection, visually check inspection doors and airplane general condition. Check for systems and parts attachments / deflections / leaks / cracks / deteriorations / non-obstructions / nicks / numbers / free movements / position.

In cold weather, remove even small accumulations of frost, ice or snow from wing, tail and control surfaces.

In case of night flight, check good operation of all navigation lights, landing lights, strobe lights and make sure that an emergency lamp is on board.

If icing conditions are foreseen, particularly check good functioning of all electrical and pneumatic ice protection systems.

Check that type and quantity of fuel used for refueling are correct.

Remove covers on : pitots (2), static ports (2), static dischargers (2), engine air inlet (1), air inlets (2), exhaust cover and propeller locks (2).



Continue ►

Preflight inspection

2/16

► Continuing

▲ WARNING ▲
Remove tie-downs.

Refer to section 8 for quantities, products and specifications of products and materials currently used.

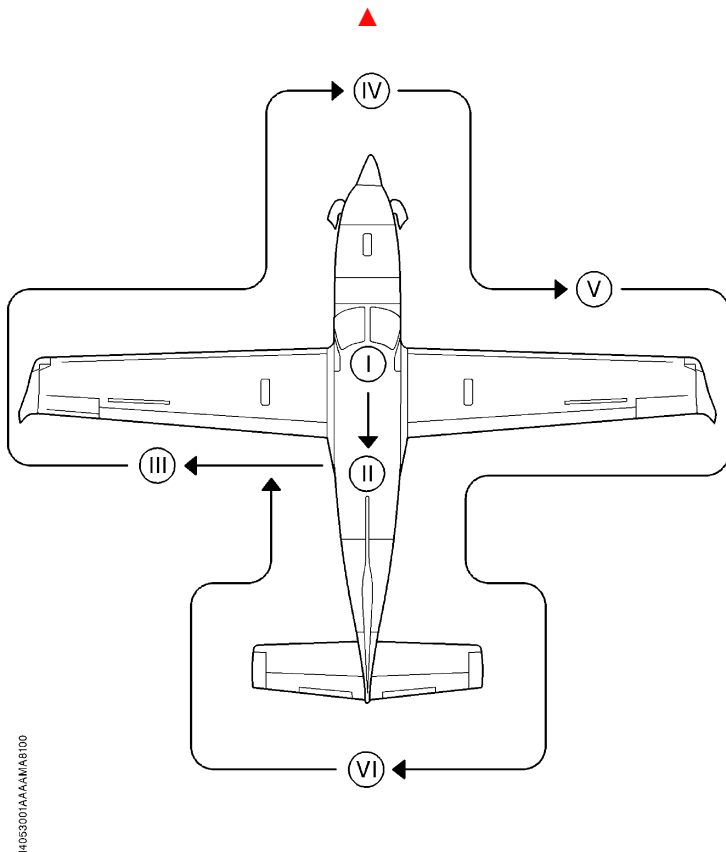

Figure 4.4.1 - Preflight inspection

Continue ►

Preflight inspection

3/16

► *Continuing*

Initial inside inspection

Cockpit (1)

▲ CAUTION ▲

When engine is shut down, do not set the PROP DE ICE switch to ON for more than 10 seconds, damage to the propeller blades could result.



1 - A/C switch OFF

■ >> *Airplane with seats heaters system (Post-MOD70-0588-25)*

2 - SEATS HTRS MASTER switch OFF

■ >> *All*

3 - DE ICE SYSTEM panel All OFF

4 - MICRO/MASK switch MICRO / Guarded

5 - Flight controls lock Removed / Stowed

● NOTE ●

The flight controls lock is normally stowed in the front cargo compartment with the towing bar and the blanking covers.



6 - Flight controls deflections Check

7 - PARK BRAKE ON

8 - LANDING GEAR lever DN

9 - DUMP switch NORM / Guarded

10 - BLEED switch OFF

Engine controls

11 - MAN OVRD control Backward

Continue ►

Preflight inspection	4/16
----------------------	------

► *Continuing*

▲ **CAUTION** ▲

When the engine is shut down, the throttle must not be moved into the reverse area as a lack of hydraulic pressure prevents movement into reverse range. Trying to force the mechanism will cause damage.



- 12 - THROTTLE CUT OFF
 - 13 - FLAPS lever UP
 - 14 - FUEL TANK SELECTOR L or R
- Open door of emergency landing compartment to check LANDING GEAR emergency control.
- 15 - Lever Pushed down
 - 16 - By-pass selector Fully depressed
 - 17 - Door In place

● NOTE ●

By-pass selector must be pushed at its maximum stop, so as to have the door in place.



- 18 - ALTERNATE STATIC SOURCE selector Pushed
 - 19 - EMERGENCY RAM AIR control knob Pushed
 - 20 - Breakers panel All breakers checked
 - 21 - ELT switch ARM / OFF
 - 22 - AP / TRIMS switch OFF
- FUEL panel
- 23 - FUEL SEL switch MAN
 - 24 - AUX BP switch OFF

Continue ►

Preflight inspection

5/16

► *Continuing*

ENGINE START panel

25 - IGNITION switch AUTO or OFF

● NOTE ●

The IGNITION switch is normally selected to AUTO. This ensures ignition, whenever the STARTER switch is set to ON.

●

26 - STARTER switch OFF

● NOTE ●

If not, starter is going to operate as soon as SOURCE selector is moved to BATT or GPU (if connected).

●

ELECTRIC POWER panel

27 - Crash lever Up

28 - GENERATOR selector MAIN

29 - SOURCE selector OFF

30 - ACCESS lighting Check
To ensure that the fuse of the BATT BUS operates correctly

31 - INT LIGHTS panel All OFF

32 - EXT LIGHTS panel All OFF

33 - OXYGEN switch OFF

34 - PASSENGER OXYGEN switch STBY

35 - Emergency lighting Check

▲ CAUTION ▲

Before selecting source, check position of ignition and starter switches.

▲

36 - IGNITION switch AUTO or OFF

37 - STARTER switch OFF

Continue ►

Preflight inspection	6/16
-----------------------------	-------------

► *Continuing*

- 38 - LANDING GEAR lever DN
- 39 - SOURCE selector BATT or GPU
- 40 - Standby instrument battery indicator symbol Not displayed

If a battery symbol appears on the standby instrument display, airplane takeoff is not allowed until the situation is resolved. Refer to the battery details in the standby instrument Pilot's guide for further information.

If BATT source :

- 41 - Voltage Check > 24.5 volts

● NOTE ●

If not, use a GPU or charge battery. This minimum voltage is not an absolute guarantee for a correctly charged battery. It is recommended to use a GPU in cold weather, when airplane has been stopped more than 3 hours at a temperature below - 10°C (+ 14°F).



If GPU source :

▲ CAUTION ▲

Low voltage (around 24.5 V) may indicate that only the battery is powering the airplane and not the pair GPU + battery.
Make sure that a GPU is connected and powering the airplane.



- 42 - Voltage Check ≈ 28 volts

● NOTE ●

If using a GPU, ensure that it provides a 28-volt regulated voltage, with negative on earth, as well as it supplies 800 amps minimum and 1000 amps maximum. See placard located near ground power receptacle door.



EXT LIGHTS panel

- 43 - OFF/TAXI/LDG switch OFF
- 44 - STROBE switch ON
- 45 - NAV switch ON

Continue ►

Preflight inspection

7/16

► *Continuing*

DE ICE SYSTEM panel

46 - All switches OFF

47 - ICE LIGHT switch ON

48 - From outside the airplane, check operation of all lights and stall warning alert.

Reentering the airplane

49 - EXT LIGHTS panel All OFF

50 - CAS display Check

51 - Left and right FUEL quantities Check

52 - FLAPS lever LDG

LANDING GEAR panel

53 - Warning lights Check 3 green ON

54 - LIGHT TEST push-button Press
Check all lights flashing

DE ICE SYSTEM panel

▲ WARNING ▲**Do not touch pitots nor stall warning vane. They could be hot enough to burn skin.**

55 - PITOT L HTR switch ON

56 - **PITOT HT ON L** Check ON*Continue* ►

Preflight inspection 8/16

► Continuing

57 - PITOT R & STALL HTR switch ON

• NOTE •

Correct operation of pitot (PITOT L and R) tube heating elements and of stall aural warning system (STALL HTR) is indicated by display of corresponding CAS message, when control switches are ON.

58 - **PITOT HT ON L-R** Check ON

59 - **STALL HEAT ON** Check ON

60 - PITOT L HTR switch OFF

61 - PITOT R & STALL HTR switch OFF

62 - Crash lever Pull down

Cabin (II)

63 - Cabin fire extinguisher Pressure / Attachment

64 - Seats / belts Check

65 - Windows General condition / No crack

66 - Emergency exit Closed / Locked

67 - Anti-theft safety pin Removed / Stowed

Continue ►

Preflight inspection

9/16

► *Continuing*

- 68 - Baggage compartment Straps in place
>> *6-seat accommodation*
- 69 - Partition net General condition / In place
>> *4-seat accommodation and baggage transportation*
- 70 - Large net or small net General condition / In place
>> *All*
- 71 - Doors operation Check
- 72 - Stairs condition Condition / Play

Outside inspection

The preflight inspection described in figure 4.4.1 is recommended before each flight.

● NOTE ●

If a preflight inspection is performed just after the engine shutdown, be careful because the leading edge of engine air inlet, as well as exhaust stubs may be very hot.

●

If the airplane was in long term storage or if it has undergone major maintenance or if it has been used from emergency airfields, a thorough outside inspection is recommended.

When the airplane is stored outside, the use of the flight control lock and blanking covers is recommended. Propeller should be tied down to prevent rotation without oil pressure.

When the airplane is stored for extended periods of time, a thorough preflight inspection is recommended. Particular attention should be paid to possible blockages in airspeed sensing lines, foreign objects in engine intake and exhaust stubs and water contamination of the fuel system.

Continue ►

Preflight inspection	10/16
-----------------------------	--------------

► *Continuing*

L.H. wing (III)

- 73 - Flap Condition / Play

Also inspect the lower surface, as well as flap fairing, where pebbles (and even ice in case of slush on the runway) may have accumulated.

- 74 - Aileron and trim / Spoiler Condition / Free movement / Deflection

● NOTE ●

Ensure there are no foreign objects in the spoiler recess. When ailerons are in the neutral position, it is normal that spoilers are lightly extended at upper surface.

●

- 75 - Trailing edge static discharger Condition / Number / Attachment

- 76 - Winglet / nav. lights / strobe / landing light /
recognition light / taxi light Condition

- 77 - OAT probe Condition

- 78 - Fuel tank cap Closed / Locked

● NOTE ●

Fuel tank caps must be tight (which is characterized by a consequent exertion to lock and unlock them) to avoid water infiltration in case of rain on ground, and to avoid fuel loss in flight.

●

- 79 - Fuel tank air vent Unobstructed

● NOTE ●

Air vent is not likely to be obstructed by ice or water, as it is located in a wing lower surface recess.

●

Continue ►

Preflight inspection**11/16**▶ *Continuing*

- 80 - Left pitot Condition
- 81 - Wing lower surface No leak
- 82 - Check fuel tank access doors for leaks.
- 83 - Check for surface damage.
- 84 - Wing deicer boots Condition / Attachment

● **NOTE** ●

Care must be taken when refuelling the airplane to avoid damaging the wing deicer boots. A protective apron should be used if possible.

●

- 85 - Fuel tank drain (two on each wing) Drain
Fuel free of water and contamination

● **NOTE** ●

In case of water in fuel system, drain it carefully using the four drain valves of tank sumps, and the fuel filter drain valve, till every trace of water or deposit has disappeared.

A long term storage of the airplane causes water accumulation in fuel, which absorbs additive. This phenomenon occurs when an excessive quantity of water accumulates in fuel tank sumps. Refer to section 8 for servicing operations relative to fuel additives.

●

L.H. main LANDING GEAR

- 86 - Shock absorber Check
- 87 - Doors Check
- 88 - Tire Check
- 89 - Wheel well Check

Continue ▶

Preflight inspection	12/16
-----------------------------	--------------

► *Continuing*

● NOTE ●

If airplane has been used from muddy airfields or in snow, check wheel wells to make sure they are clean and not obstructed.

Check frequently all landing gear retraction mechanism components, shock-absorbers, tires and brakes. This is particularly important for airplanes used from hilly fields.

Improperly serviced or worn shock-absorbers may result in excessive loads being transmitted to the airplane structure during ground operations. Without passengers and baggages on board, the unpainted surface of the main gear shock absorber tube must be visible about :

- 55 mm (2.17 in) of minimum height with half tank,
- 40 mm (1.57 in) of minimum height with full tanks.



Fuselage forward section (IV)

Forward compartment

- | | | |
|---|-------------------------------|-----------------------------------------------|
| | 90 - Inside | Check |
| | 91 - Door | Close / Lock |
| ■ | 92 - GPU door | Closed
If not used |
| ■ | 93 - Fuel circuit drain | Drain
Fuel free of water and contamination |

▲ WARNING ▲

If the clogging indicator is extended, red collar visible, the flight is not authorized.



- | | | |
|---|----------------------------------------------------------------|-----------------------|
| | 94 - Filter contamination indicator (clogging indicator) | Check |
| ■ | 95 - L.H. exhaust stub | Condition / No cracks |
- Continue ►*

Preflight inspection**13/16**▶ *Continuing*

● NOTE ●

Inspect if possible pressure port located inside exhaust stub. A missing port or a cracked port may hinder correct operation of continuous heating of air inlet lip.

●

- 96 - Upper engine cowl Open

For the first flight of the day :

- 97 - Oil cap Closed / Locked

- 98 - Engine oil level Check

- 99 - Fuel pipes No leak, deterioration, wear

- 100 - Engine cowl Condition
-
- Closed / Locked

Air inlets

- 101 - Main No cracks - Unobstructed

● NOTE ●

Check for no cracks, which are sometimes put in evidence by traces of soot resulting from exhaust gases.

●

- 102 - Lateral / upper Unobstructed

● NOTE ●

Lateral air inlets, which supply air conditioning system and oil cooler, are provided with blanking covers. It is not the case for upper air inlets of RAM AIR system (circular grille located in front of R.H. windshield) and of vapor cycle cooling system (two rectangular grilles located forward of the circular grille).

●

Continue ▶

Preflight inspection	14/16
----------------------	-------

► *Continuing*

- 103 - Propeller and spinner No nicks, cracks or oil leaks / Attachment

● NOTE ●

In case of operation from contaminated runways, it is necessary to carefully examine propeller blades, where traces of abrasion may be found. Propeller damage may reduce blade life time and degrade performance. Any propeller damage should be referred to maintenance personnel.



Nose gear

- 104 - Shock absorber Check
- 105 - Doors Check
- 106 - Tire Check
- 107 - Wheel well Check

● NOTE ●

Without passengers and baggages on board, the unpainted surface of the nose gear shock absorber tube must be visible about :
57 mm (2.22 in) of minimum height with full tanks,
63 mm (2.46 in) of minimum height with half tank.



● NOTE ●

Crush or relieve the shock absorber one time or twice before the inspection to remove possible sticking.



In case of doubt, request a check of the shock absorber pressure.

- 108 - R.H. exhaust stub Condition / No cracks

R.H. wing (V)

Additional remarks are identical to those of L.H. wing.

- 109 - Fuel tank drain (two on each wing) Drain
Fuel free of water and contamination

Continue ►

Preflight inspection	15/16
-----------------------------	--------------

► *Continuing*

R.H. main LANDING GEAR

- 110 - Shock absorber Check
- 111 - Doors Check
- 112 - Tire Check
- 113 - Wheel well Check
- 114 - Wing deicer boots Condition / Attachment
- 115 - Stall warning Condition / Deflection
- 116 - Wing lower surface No leaks
- 117 - Fuel tank cap Closed / Locked
- 118 - Fuel tank air vent Unobstructed
- 119 - Right pitot Condition
- 120 - Winglet / nav. light / strobe / landing light /
recognition light / taxi light Condition
- 121 - Trailing edge static discharger Condition / Number / Attachment
- 122 - Aileron / spoiler Condition / Free movement / Deflection
- 123 - Flap Condition / Play

Rear R.H. karman

- 124 - Oxygen cylinder Open
- 125 - Oxygen pressure Check
- 126 - Confirm OXYGEN quantity in regards with the expected flight.
- 127 - Oxygen pressure Check

Fuselage rear section / empennages (VI)

Check that outside handle of emergency exit is flush with door skin.

- 128 - ELT ARM / OFF

Continue ►

Preflight inspection	16/16
----------------------	-------

► *Continuing*

■ 129 - ELT door Closed / Locked

● NOTE ●

Access to ELT is possible through an inspection door located on R.H. side of fuselage rear section.

●

■ 130 - Static pressure ports Clean

■ 131 - Ventral fins Condition / Attachments

● NOTE ●

Ventral fins are made of two parts (one fixed part and one removable part with rear lower inspection door). Check that these two parts are connected by the locking roller.

●

■ 132 - Inspection door under fuselage Attachments - Closed

133 - Horizontal stabilizer deicer boots (R.H. side) Condition / Attachments

134 - Elevator and trim Condition / Deflection free movement / Trim position

● NOTE ●

To check the deflection, hold the two half-elevators near fuselage, inside both elevator trims to avoid stresses.

●

■ 135 - Static dischargers Condition

136 - Vertical stabilizer deicer boots Condition / Attachments

137 - Rudder and trim Condition / Trim position

138 - Static dischargers Condition

139 - Tail cone / nav. lights / strobe Condition

140 - Static pressure ports Clean

End of procedure.

Inside inspection

1/4

After completion of preflight inspection. Initial inside inspection and outside inspection performed.

- 1 - Cabin door and pilot door, if installed Closed / Locked
- 2 - Baggage Stowed
- 3 - EMERGENCY EXIT pin Removed
- 4 - Seats, pedals, harness Adjust / Lock

▲ CAUTION ▲

It is mandatory to set the seat to the highest position before adjusting the front seats fore or aft. Otherwise, moving the seat may damage the upholstery on the side panels.



Pilot seat and R.H. front seat, if occupied Adjust

● NOTE ●

Adjust seats and harnesses to ensure access to flight controls. The pilot at L.H. position must be able to easily reach the A/C and PRESSURIZATION panel.



- 5 - Height adjustment Max. UP
- 6 - Fore and aft adjustment Adjust and check locking
- 7 - Height adjustment Adjust
- 8 - L.H and R.H. pedals Adjust
- 9 - Pilot and passengers belts and harnesses Fasten

● NOTE ●

Check for the correct locking of belt buckles for the pilot and passengers ; as well as automatic locking of shoulder harness by exerting a rapid pull on the harness.

If airbags are installed, unoccupied seat belts need to be strapped. It is prohibited to fly with these belts unstrapped.

*Continue ►*

Inside inspection	2/4
-------------------	-----

► *Continuing*

- 10 - PASSENGER OXYGEN switch STBY
- 11 - OXYGEN switch ON

● NOTE ●

Make sure to set on STBY the PASSENGER OXYGEN switch before setting the OXYGEN switch to ON to avoid passengers mask deployment.



- 12 - Crew oxygen masks Test

● NOTE ●

Press push-button PRESS TO TEST : the blinker shall turn red momentarily, then turns transparent.



- 13 - EXT LIGHTS panel All OFF
- 14 - INT LIGHTS panel All OFF
- 15 - DIMMER switch OFF
- 16 - CABIN switch OFF
- 17 - ACCESS switch OFF
- 18 - PANEL rheostat Fully turned to the left
- 19 - All lights OFF
- 20 - Crash lever Down
- 21 - STARTER switch OFF

● NOTE ●

If not, starter is going to operate as soon as SOURCE selector is positioned on BATT or GPU.



Continue ►

Inside inspection

3/4

► *Continuing*

22 - IGNITION switch AUTO

• NOTE •

The IGNITION switch is normally selected to AUTO. This ensures ignition, whenever the starter is activated.

•

23 - AUX BP switch OFF

24 - FUEL SEL switch MAN

25 - AP / TRIMS switch OFF

26 - A/C switch OFF

■ >> *Airplane with seats heaters system (Post-MOD70-0588-25)*

27 - SEATS HTRS MASTER switch OFF

■ >> *All*

28 - CB LIGHTS switch OFF

29 - MICRO / MASK switch MICRO / Guarded

30 - DE ICE SYSTEM panel All OFF

31 - INERT SEP switch OFF

32 - PARK BRAKE Reset / ON

33 - LANDING GEAR lever DN

34 - DUMP switch NORM / Guarded

35 - BLEED switch OFF

36 - HOT AIRFLOW distributor Fully turned to the right

37 - Pitch trim wheel Check

Continue ►

Inside inspection	4/4
-------------------	-----

► *Continuing*

▲ **CAUTION** ▲

Make sure that MAN OVRD control is backward to avoid
overtemperature risks at start.



- 38 - MAN OVRD control Full backward (notched)

▲ **CAUTION** ▲

When the engine is shut down, the THROTTLE must not be moved into
the reverse area.



- 39 - THROTTLE CUT OFF
- 40 - FUEL TANK SELECTOR Open / L or R
- 41 - ALTERNATE STATIC SOURCE selector Normal / Pushed
- 42 - EMERGENCY RAM AIR Closed / Pushed
- 43 - ESS BUS TIE switch NORM / Guarded
- 44 - Breakers All pushed
- 45 - EMERGENCY LANDING GEAR lever Check

End of procedure.

Before starting engine

1/3

Check that the weight and balance are within the correct limits. Brief passengers about use of seat belts and the emergency oxygen system, as well as opening the access door and the emergency exit.

- 1 - Preflight inspection Completed
- 2 - Crash lever Up
- 3 - ATIS Copied
- 4 - Start clearance As required
- 5 - SOURCE selector BATT (battery start) or GPU (GPU start)

If one screen (L or R PFD, or MFD) is missing :

- 6 - SOURCE selector OFF
- 7 - Wait for 30 seconds
- 8 - SOURCE selector BATT (battery start) or GPU (GPU start)

If GPU use :

- 9 - **GPU DOOR** Check ON
- 10 - Voltmeter Check 28 Volts ± 0.5 Volt

• NOTE •

Voltage is higher than 24.5 Volts which corresponds to the voltage in case of battery use.

•

If battery use :

- 11 - Battery voltage Check > 24.5 V

If battery voltage < 24.5 V :

- 12 - Ask for a GPU and be ready to a GPU start.

- 13 - GENERATOR selector MAIN
- 14 - **MAIN GEN** Check ON

Continue ►

Before starting engine

2/3

► Continuing

15 - **O2 CYL CLOSED** Check OFF

If **O2 CYL CLOSED** is ON :

16 - Open isolation valve of the oxygen cylinder in R.H. Karman.

17 - TEST push-button Press
Audio / DE ICE SYSTEM lights / stick shaker

18 - DUMP switch NORM / Guarded

19 - LANDING GEAR light / CHECK DOWN Test

20 - MFD Initialize

21 - Fuel onboard Check

- Quantity Check

- FUEL TANK SELECTOR L or R

22 - Residual ITT Check

If residual ITT > 150°C :

23 - Perform procedure Motoring
Refer to this chapter

• NOTE •

A start up procedure with an engine residual ITT above 150°C may generate an ITT exceedance.

Particular monitoring of ITT will have to be performed during start up to ensure to keep the temperature within ITT envelope.

•

24 - VOLTS : BAT > 24.5 V / GPU ≈ 28 V Check

25 - CAS display Check

26 - PARK BRAKE Check ON
Last check before proceeding to engine start

Continue ►

Before starting engine

2/3

► *Continuing*

27 - **PARK BRAKE** Check ON

• NOTE •

PARK BRAKE appearance does not indicate that parking brake is set. For that, press on brake pedals before turning brake selector to the right.

•

End of procedure.

Engine start	1/3
--------------	-----

- 1 - STROBE switch ON
- 2 - G3000 DISPLAY BACKUP
Composite mode

● NOTE ●

If there is a loss of MFD during start up sequence, that sequence will be ended using the left PFD in composite mode.



- 3 - IGNITION switch AUTO
- 4 - AUX BP switch ON
- 5 - **AUX BOOST PMP ON** Check ON
- 6 - **FUEL PRESS** Check OFF
- 7 - Propeller area Clear

▲ CAUTION ▲

If 5 seconds after having positioned the STARTER switch in ON position there is no start, interrupt starting attempt using the ABORT position of the STARTER switch.



▲ CAUTION ▲

Starter operation is bound by limitations in chapter 2.4 Starter operating limits.



- 8 - STARTER switch ON
2 sec then OFF

Simultaneously :

- 9 - Timer clock Start
To check startup acceleration
- 10 - **STARTER** Check ON
- 11 - **MAIN GEN** Check ON

Continue ►

Engine start 2/3

► *Continuing*

▲ **CAUTION** ▲

When THROTTLE is positioned on LO-IDLE before having obtained 13 % of Ng, there is a risk of overtemperature further to an excessive accumulation of fuel inside the combustion chamber before ignition.



● **NOTE** ●

In case of starting with high residual ITT, an ITT decrease below 150°C (within starter operation limits) may allow to stay within the allowed ITT envelope during startup sequence.



When

- Ng about 13 % and,
- ITT below 150°C and,
- time below 20 seconds :

12 - THROTTLE LO-IDLE

Abort starting procedure if :

- No ignition 10 seconds after having positioned THROTTLE to LO-IDLE,
- **ITT** lights on (max ITT < 870°C for more than 20 seconds, < 1000°C for more than 5 seconds),
- Ng < 30 % after 30 seconds of starter use,
- Ng < 50 % after 60 seconds of starter use,

13 - THROTTLE CUT OFF

14 - IGNITION switch OFF or AUTO

When ITT < 850°C :

15 - STARTER switch ABORT

End of procedure ■

Continue ►

Engine start	3/3
--------------	-----

► *Continuing*

When

- *Ng > 50 % and,*
- *1 minute max :*

▲ **CAUTION** ▲

If the starter does not go off automatically, disengage it using the
ABORT position of the STARTER switch.



- 16 - Starter Check OFF automatically
- 17 - **STARTER** Check OFF
- 18 - Engine parameters Check
Check $54 \% \leq Ng \leq 58 \%$, oil pressure and ITT in green sector

End of procedure.

Motoring

1/3

To drain fuel accumulated inside the combustion chamber, a motoring procedure is required following an aborted start.

A 15-second dry motoring run is sufficient to clear any fuel pooled in the engine. The fuel is removed in liquid or vapor form, through an airflow intended to dry combustion chamber, turbines and exhaust nozzles.

To improve cooling of the bearing cavities and prevent oil coking after shutdown in high OAT [above 35°C (95°F)] environment, it is recommended to perform a 30-second dry motoring run.

It is possible that no trace of drainage be observed under engine, due to the drainage collector intended to prevent parking area from contamination.

▲ CAUTION ▲

After any starting interrupt procedure, wait for engine total shutdown and wait at least 30 seconds before initiating a motoring.



Engine controls

- 1 - MAN OVRD control Full backward (notched)

▲ CAUTION ▲

When the engine is shut down, the THROTTLE must not be moved into the reverse area.



- 2 - THROTTLE CUT OFF
3 - IGNITION switch OFF
4 - **IGNITION** Check OFF

Fuel

- 5 - FUEL TANK SELECTOR L or R
6 - AUX BP switch ON
7 - **AUX BOOST PMP ON** Check ON

Continue ►

Motoring 2/3

► *Continuing*

8 - **FUEL PRESS** Check OFF
Fuel pressure is necessary for lubrication of HP pump.

9 - Propeller area Clear

To clear fuel and vapor internally trapped :

10 - STARTER switch ON
2 sec then OFF

Simultaneously :

11 - Timer clock Start

12 - **STARTER** Check ON

13 - Motor For 15 sec. max

14 - STARTER switch ABORT
Then OFF

15 - **STARTER** Check OFF

To cool engine following shutdown in high temperature environment :

16 - STARTER switch ON
2 sec then OFF

Simultaneously :

17 - Timer clock Start

18 - **STARTER** Check ON

19 - Motor For 30 sec. max

If ignition symptoms occur (ITT increasing) :

20 - IGNITION switch Check OFF

21 - THROTTLE Check CUT OFF

22 - Continue motoring.

Continue ►

Motoring 3/3

► Continuing

23 - STARTER switch ABORT
Then OFF

24 - **STARTER** Check OFF

FUEL panel

25 - AUX BP switch OFF

26 - **AUX BOOST PMP ON** Check OFF

27 - **FUEL PRESS** Check ON

End of procedure.

Motoring followed by an engine start	1/3
---------------------------------------------	------------

Amplified procedures stated in starting engine sequences using airplane power or with GPU are also to be applied to hereunder procedure.

Within starter operating limits (continuous max. 1 minute), it is possible to initiate a starting procedure from a motoring procedure.

This procedure will conserve the battery by taking advantage of first Ng acceleration.

Engine controls

- 1 - MAN OVRD control Full backward (notched)

▲ **CAUTION** ▲

When the engine is shut down, the THROTTLE must not be moved into the reverse area.



- 2 - THROTTLE CUT OFF
- 3 - IGNITION switch OFF
- 4 - **IGNITION** Check OFF

Fuel

- 5 - FUEL TANK SELECTOR L or R
- 6 - AUX BP switch ON
- 7 - **AUX BOOST PMP ON** Check ON
- 8 - **FUEL PRESS** Check OFF
Fuel pressure is necessary for lubrication of HP pump.
- 9 - Propeller area Clear
- 10 - STARTER switch ON
2 sec then OFF

Simultaneously :

- 11 - Timer clock Start
- 12 - **STARTER** Check ON

Continue ►

Motoring followed by an engine start**2/3**▶ *Continuing*

13 - Motor For 30 sec. max

After 20 seconds and if ITT < 150°C :

14 - IGNITION switch AUTO

15 - Ng Check > 13 %

16 - THROTTLE LO-IDLE

Monitor increase of :

17 - ITT max. : < 870°C for 20 sec max.
< 1000°C for 5 sec max.

18 - Ng

19 - Oil pressure

20 - **OIL PRESS** Check OFF*When Ng > 50 % :*▲ **CAUTION** ▲If the starter does not go off automatically, disengage it using the
ABORT position of the STARTER switch.

21 - Starter Check OFF automatically

22 - **STARTER** Check OFF23 - Engine parameters Check
Check 54 % ≤ Ng ≤ 58 %, oil pressure and ITT in green sector

Fuel panel

24 - AUX BP switch AUTO

25 - **AUX BOOST PMP ON** Check OFF*Continue* ▶

Motoring followed by an engine start 3/3

► Continuing

Electric power

26 - **MAIN GEN** Check OFF
Reset if necessary

• NOTE •

MAIN GEN normally goes off as soon as **STARTER** goes off.

•

If **MAIN GEN** does not go off :

27 - Ng Increase to more than 70 %
To start main generator

28 - Generator and battery AMPS Check charge
On EIS of MFD

29 - Battery and ESS. bus VOLTS Check voltage ≈ 28 Volts
On EIS of MFD

End of procedure.

After engine start with GPU

- 1 - SOURCE selector BATT
- 2 - Electrical network Check
- 3 - GPU Disconnect
Performed by ground personnel
- 4 - **GPU DOOR** Check OFF
- 5 - GENERATOR selector MAIN
- 6 - **MAIN GEN** Check OFF

• NOTE •

MAIN GEN normally goes off as soon as **STARTER** goes off.

•

If **MAIN GEN** does not go off :

- 7 - Ng Increase over 70 %
To start main generator
- 8 - Generator and battery AMPS Check charge
On EIS of MFD
- 9 - Battery and ESS. bus VOLTS Check voltage ≈ 28 Volts
On EIS of MFD
- 10 - CAS display Check
- 11 - A/C switch As required
- 12 - BLEED switch AUTO or MAX DIFF

When ground personnel is cleared from propeller area :

- 13 - Perform procedure After engine start
Refer to procedure hereafter

End of procedure.

After engine start 1/2

▲ **CAUTION** ▲

Generator load < 200 amps



- 1 - THROTTLE LO-IDLE ► Flight IDLE
- 2 - Ng Check 70 % ± 2 %
- 3 - OIL °C and OIL PSI Check
- 4 - AUX BP switch AUTO
- 5 - FUEL SEL switch AUTO
- 6 - SHIFT push-button Test
Verify rotation of FUEL TANK SELECTOR
- 7 - AP / TRIMS switch ON
This initializes the A/P system
- 8 - PFD 1, MFD and PFD 2 NORMAL mode

Perform generator test :

- 9 - BLEED switch OFF
To unload the generator circuit
- 10 - GENERATOR selector Check MAIN
- 11 - AMPS / VOLTS Check

When MAIN LOAD < 80 amps :

- 12 - GENERATOR selector ST-BY
- 13 - AMPS / VOLTS Check

If the voltage on the ST-BY generator is low (close to 27 volts) :

- 14 - GENERATOR RESET ST-BY push-button Press
To reset ST-BY generator
- 15 - AMPS / VOLTS Check
The indicated voltage should be in the green range
- 16 - GENERATOR selector MAIN

Continue ►

After engine start 2/2

► *Continuing*

17 - Oxygen Check
Verify quantity available for the planned flight.
See tables of the paragraph : In-flight available oxygen quantity,
in this chapter, and in chapter 7.10 for an FAR 135-type operation

PFD 1, MFD and PFD 2

● NOTE ●

Detailed control procedures of the avionics system are described in the
GARMIN Integrated Flight Deck Pilot's Guide.

●

18 - Brightness Adjust

19 - DISPLAY BACKUP push-button Check
Then return to NORMAL mode

20 - CAS Check
Check engine parameters

21 - A/C switch As required

● NOTE ●

Cabin temperature will not be properly regulated when the A/C switch is set
to OFF.

●

22 - TEMP selector Adjust

>> *Airplane with seat heaters (Post-MOD70-0588-25)*

23 - SEATS HTRS MASTER switch As required

>> *All*

24 - BLEED switch AUTO or MAX DIFF

25 - HOT AIR FLOW distributor As required

● NOTE ●

The HOT AIR FLOW distributor is normally set turned fully to the right. If the
windshield requires defogging, turn it fully to the left.

●

End of procedure.

In-flight available oxygen quantity
 (Crew oxygen masks in NORMAL mode)

- 1 - Oxygen pressure Read
- 2 - Outside air temperature (OAT) Read
- 3 - Determine the usable oxygen percent using the chart of figure 4.4.2

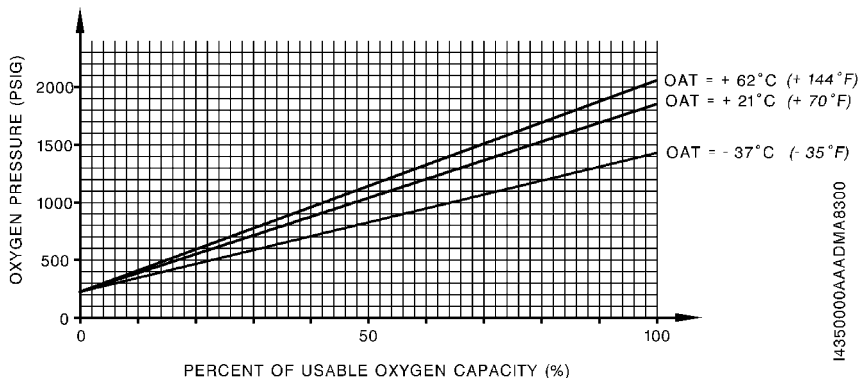

Figure 4.4.2 - Usable oxygen

- 4 - Determine the oxygen duration in minutes by multiplying the values in the figure 4.4.3 table by the percent obtained with the chart of figure 4.4.2

Number of passengers	Duration : Passengers, plus 1 pilot	Duration : Passengers, plus 2 pilots
0	226	113
1	162	94
2	127	81
3	104	71
4	88	65

Figure 4.4.3 - Oxygen duration

End of procedure.

Before taxiing**1/4**

- 1 - Stand-by instruments Check
Check de-ice system

• NOTE •

Flight into known icing conditions is authorized only when all ice protection equipment are operating correctly. This equipment may be activated before takeoff, even during taxiing, in case of icing conditions on ground. Refer to chapter 4.5 Particular procedures of this section.

•

- 2 - PROP DE ICE switch ON
3 - Check illumination of the green light located above the switch.

• NOTE •

Illumination of the green light shows that electric power is supplied to blade root electric resistors. It is advised to wait at least a whole half cycle (90 seconds) to check that both blade heating systems are correctly supplied with electric power.

•

- 4 - PROP DE ICE switch OFF
5 - WINDSHIELD switch ON
6 - Check illumination of the green lights located above the switch (except if hot conditions).

• NOTE •

These lights may remain OFF if cabin temperature is very high, for example after a prolonged parking in hot conditions (see chapter 7.13 for operational principle).

•

- 7 - WINDSHIELD switch OFF

Continue ►

Before taxiing 2/4

► *Continuing*

- 8 - Ng Increase > 80 %
To check AIRFRAME DE ICE

● NOTE ●

Theoretically, necessary air bleed to inflate wing and empennage leading edges, as well as depression necessary to their deflation are sufficient when THROTTLE is positioned on Flight IDLE. However, it is advised for check to choose a Ng power > 80 % in order to obtain operation design pressure, which enables illuminating surely the two green lights and avoiding **VACUUM LOW** untimely alarms.



- 9 - AIRFRAME DE ICE switch ON
- 10 - Visually check functioning of deicer boots during 1 total cycle and illumination of the two green lights located above the switch.

● NOTE ●

The cycle lasts 67 seconds. Check both inflation impulses and illumination of each corresponding green light :

- the first impulse inflates the external and middle wing boots,
- the second impulse inflates the leading edge boots of empennages and inner wing.



- 11 - AIRFRAME DE ICE switch OFF
- 12 - INERT SEP switch ON
Keep ON while taxiing in order to avoid ingestion of particles by the engine
- 13 - Flight controls Check
Proper operation from stop to stop, full deflection

Check autopilot and electrical pitch trim :

- 14 - AP / TRIMS Check

● NOTE ●

Detailed control procedures of autopilot and electrical pitch trim are described in the GARMIN Integrated Flight Deck Pilot's Guide.



Continue ►

Before taxiing	3/4
----------------	-----

► *Continuing*

- 15 - Pitch trim UP / DN
- 16 - Pitch trim Adjust in green range
Graduated from 12 to 37 %
- 17 - Yaw trim L / R
- 18 - Yaw trim Adjust in green range
Takeoff range
- 19 - Roll trim L / R
- 20 - Roll trim Adjust at neutral position
- 21 - FLAPS lever UP

Perform MFD flight management

- 22 - Weight computing Set / Check
- 23 - FOB (fuel on board) synchronization Set

If requested :

- 24 - FPL Set
- 25 - LFE selection Done

Landing Field Elevation selection is done on the touchscreen controller using either :

- automatically the destination airport of the flight plan,
- or
- a manual entry by pressing : HOME, AIRCRAFT SYSTEMS, LFE and then MANUAL.

- 26 - VHF/VOR/GPS Adjust / Test
- 27 - Radar Adjust / Test
- 28 - Stormscope/TAS/TAWS/Radio altimeter, if installed Adjust / Test
- 29 - ADI/HSI on PFD1 / PFD2 Check
- 30 - Altimeter setting Set / Check

Continue ►

Before taxiing 4/4

► *Continuing*

▲ **CAUTION** ▲

During feathering test, keep the spent time with the propeller RPM in the caution (yellow) range at a minimum.



- 31 - THROTTLE FEATHER twice
Flight IDLE to LO-IDLE then Flight IDLE, twice
- 32 - EIS Check
- 33 - CAS display Check
- 34 - Passenger briefing As required
- 35 - TAXI lights ON
- 36 - PARK BRAKE OFF
Make sure that chocks are removed, if used
- 37 - **PARK BRAKE** Check OFF

End of procedure.

Taxiing

▲ CAUTION ▲

Generator load < 200 amps.



▲ CAUTION ▲

Avoid using reverse during taxiing.



● NOTE ●

Operation in the Beta (β) range / reverse is not restricted during ground operations. However, foreign particles (dust, sand, grass, gravel, etc...) may be blown into the air, ingested by the engine (above all if INERT SEP switch is turned OFF) and cause damage to the propeller.



- 1 - TAXI lights Check ON
- 2 - THROTTLE As required

● NOTE ●

After initial acceleration, THROTTLE may be in the TAXI range sector, avoiding excessive movements in order to keep a constant ground speed.



- 3 - Brakes Test
- 4 - Nose wheel steering Check
Check that the control wheel moves (roll) in the same direction as the rudder pedals due to the rudder / aileron interconnect.
- 5 - Flight instruments Check
Check navigation and communication systems before or during taxiing, check gyroscopic instruments on PFDs 1 / 2 and stand-by indicator during ground turns.

End of procedure.

Before line up	1/4
----------------	-----

▲ CAUTION ▲
Generator load < 200 amps.



- 1 - PARK BRAKE ON
- 2 - **PARK BRAKE** Check ON
- 3 - THROTTLE Flight IDLE
Ng = 69 % ± 2 %
- 4 - LDG lights ON
- 5 - NAV switch ON
- 6 - STROBE switch ON
- 7 - IGNITION As required
AUTO or ON
- 8 - AUX BP switch AUTO
- 9 - FUEL SEL switch AUTO

DE ICE SYSTEM panel

- 10 - AIRFRAME DE ICE switch As required
- 11 - PROP DE ICE switch As required
- 12 - WINDSHIELD switch As required
- 13 - PITOT L HTR switch ON
- 14 - PITOT R & STALL HTR switch ON
- 15 - INERT SEP switch ON

If icing conditions are foreseen :

- 16 - Perform procedure Flight into known icing conditions
Refer to chapter 4.5

Continue ►

Before line up	2/4
----------------	-----

► *Continuing*

Adjust trims for takeoff

- 17 - Pitch TO
Adjust inside green index sector,
depending on the current balance condition
- 18 - Yaw TO
Adjust inside green index sector
- 19 - Roll TO
Adjust at neutral position
- 20 - FLAPS lever TO
- 21 - Flight controls Check
Check again for proper operation from stop to stop,
full deflection
- 22 - A/C switch As required
- 23 - BLEED switch AUTO or MAX DIFF
- 24 - LFE Check
- 25 - FUEL gages Check quantity and imbalance

▲ **CAUTION** ▲

Do not take off if battery charge > 50 amps ± 4 amps.



● NOTE ●

After starting engine with airplane power, a battery charge above 50 amps is normal. If this indication remains steady at a high value, it may be then a battery or generation system failure. Do not take off in these conditions.



- 26 - AMPS Check below **50 amps**
- 27 - **BAT AMP** Check OFF
- 28 - EIS Check

Continue ►

Before line up	3/4
----------------	-----

► *Continuing*

- 29 - CAS display Check
All messages OFF,
except **PARK BRAKE** and, if used **INERT SEP ON**
- 30 - Altimeter setting Set / Check
- 31 - Instruments departure setting Check
- 32 - SID Set
- 33 - ALT SEL Set
- 34 - XPDR Set
- 35 - VHF/VOR/GPS/XPDR Adjust / Check
- 36 - Stormscope/TAS/TAWS/ADF, if installed Adjust / Check
- 37 - Radar Adjust / Check
On ground, maintain radar on STANDBY
in order not to generate radiations prejudicial to outside persons.
- 38 - Radio altimeter, if installed Adjust / Check
- 39 - Transponder code Adjust / Check
- 40 - Takeoff distances Check
Refer to chapter 5.9

Continue ►

Before line up 4/4

► *Continuing*

41 - Rotation airspeed (V_R) Check

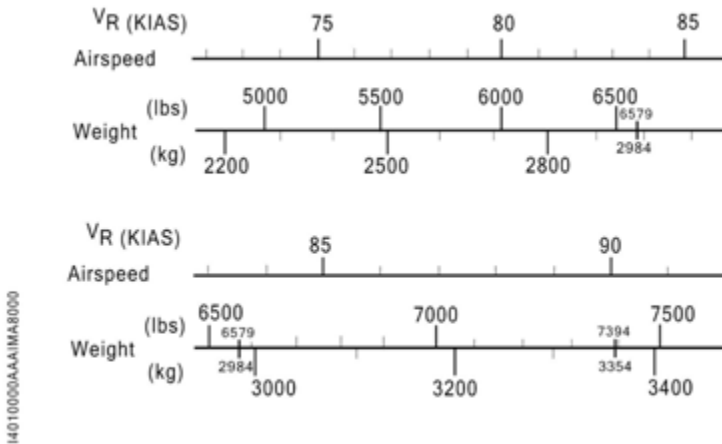

42 - Pilot's / Passengers' belts Check

43 - Passengers' table Stowed

44 - Engine instruments Check

All engine parameters must be in green range,
except propeller RPM, which will be about 1000 RPM or more
with THROTTLE at Flight IDLE.

45 - PARK BRAKE OFF

46 - **PARK BRAKE** Check OFF

End of procedure.

Normal takeoff	1/2
----------------	-----

When lined up, on brakes :

▲ CAUTION ▲

If heavy precipitation, turn IGNITION and INERT SEP switches to ON.
If icing conditions are foreseen, refer to chapter 4.5, paragraph Flight into known icing conditions.



- 1 - ADI / HSI / headings Check
- 2 - Horizon Check attitude $\approx + 2^\circ$

● NOTE ●

Horizon has been set so as to indicate a 2° nose up attitude, when airplane center of gravity is at a middle average.



- 3 - HSI - Heading - Stand-by compass Check

● NOTE ●

The indication of the stand-by compass is disturbed when windshield deice systems are activated.



- 4 - OFF/TAXI/LDG switch LDG
- 5 - Engine instruments Check
ITT in green sector

- 6 - CAS display Check
All messages OFF, except **IGNITION** and **INERT SEP ON**, if used

- 7 - Apply brakes and increase power.

- 8 - PROP RPM Check green sector

- 9 - Brakes Release

- 10 - TRQ 100 %

● NOTE ●

Torque will be about 40 % to 60 % before brake release. For a normal takeoff, maximum torque (100 %) will be applied after brakes release.



Continue ►

Normal takeoff

2/2

► *Continuing*

11 - Rotation airspeed

12 - Attitude 10° Up

*When vertical speed is positive :*13 - Brakes Apply
Briefly14 - LANDING GEAR lever UP
Airspeed < 150 KIAS

● NOTE ●

During the sequence :

- The amber caution light flashes. It indicates that the landing gear pump is running. It goes off when the 3 landing gears are up locked. GEAR UNSAFE red warning light ON and **GEAR UNSAFE** indicate an anomaly (refer to chapter 3.7 Emergency procedures).
- It is possible that the 3 landing gear position green indicator lights flash unevenly then go off at the end of the sequence.

●

15 - GEAR UNSAFE red warning light
and **GEAR UNSAFE** Check OFF
At the end of the sequence*In case of initial climb at Vx :*

▲ WARNING ▲

It is recommended not to retract FLAPS to UP before 500 ft AGL.

▲

16 - Airspeed 100 KIAS

When airspeed above 115 KIAS :

17 - FLAPS lever UP

End of procedure.

Short takeoff	1/3
---------------	-----

When lined up, on brakes :

▲ **CAUTION** ▲

If heavy precipitation, turn IGNITION and INERT SEP switches to ON.
If icing conditions are foreseen, refer to chapter 4.5, paragraph Flight into known icing conditions.



- 1 - ADI / HSI / headings Check
- 2 - Horizon Check attitude $\approx + 2^\circ$

● NOTE ●

Horizon has been set so as to indicate a 2° nose up attitude, when airplane center of gravity is at a middle average.



- 3 - HSI - Heading - Stand-by compass Check

● NOTE ●

The indication of the stand-by compass is disturbed when windshield deice systems are activated.



- 4 - OFF/TAXI/LDG switch LDG
- 5 - Engine instruments Check
ITT in green sector
- 6 - CAS display Check
All messages OFF, except **IGNITION** and **INERT SEP ON**, if used
- 7 - Apply brakes and increase power.
- 8 - PROP RPM Check green sector
- 9 - TRQ 100 %

Continue ►

Short takeoff	2/3
---------------	-----

► *Continuing*

10 - Brakes Release

● NOTE ●

On short runway, maximum torque will be applied before brakes release.



11 - Rotation airspeed

Weight < 6579 lbs (2984 kg) :

12 - Attitude 15° Up

Weight > 6579 lbs (2984 kg) :

13 - Attitude 12.5° Up

When vertical speed is positive :

14 - Brakes Apply
Briefly

15 - LANDING GEAR lever UP
Airspeed < 150 KIAS

● NOTE ●

During the sequence :

- The amber caution light flashes. It indicates that the landing gear pump is running. It goes off when the 3 landing gears are up locked. GEAR UNSAFE red warning light ON and **GEAR UNSAFE** indicate an anomaly (refer to chapter 3.7 Emergency procedures).
- It is possible that the 3 landing gear position green indicator lights flash unevenly then go off at the end of the sequence.



16 - GEAR UNSAFE red warning light
and **GEAR UNSAFE** Check OFF
At the end of the sequence

Continue ►

Short takeoff	3/3
---------------	-----

► *Continuing*

In case of initial climb at Vx :

▲ **WARNING** ▲

It is recommended not to retract FLAPS to UP before 500 ft AGL.



17 - Airspeed 100 KIAS

When airspeed above 115 KIAS :

18 - FLAPS lever UP

End of procedure.

After takeoff

- 1 - LANDING GEAR lever Check UP
- 2 - FLAPS lever Check UP
- 3 - TRQ Check 100 % max
- 4 - Climb airspeed 124 KIAS
- 5 - EIS Check
- 6 - CAS display Check
- 7 - DE ICE SYSTEM panel As required
- 8 - INERT SEP switch As required

End of procedure.

Climb	1/2
--------------	------------

- 1 - ALT SEL Check
- 2 - Altimeters setting As required
- 3 - Autopilot Check
 Autopilot status and yaw damper ON

▲ CAUTION ▲

Observe TRQ / Ng / Np / ITT / OIL T° and PSI limitations.
 Use optimum torque and / or refer to tables in chapter 5.8.



- 4 - TRQ adjustment / ITT / Ng Check

● NOTE ●

Torque setting during climb must be adjusted according to engine operation tables in chapter 5.8. These tables give the max. climb power torque setting (MXCL). For each engine, when torque is reduced below 100 % at high altitude according to the tables, during the final climb, reaching the maximum permitted Ng (104 %) is possible and the ITT will be approximately constant, giving a particular value of ITT.

For a simplified engine operation during climb, power may be set first of all by torque, using 100 %, then, when the ITT typical value for climb is reached, by indicated ITT, using this particular value. The margin between this indicated ITT and 790°C (recommended ITT limit during continuous operation) will gradually reduce as flight time is performed.



- 5 - Climb airspeed 124 KIAS
 Performance tables concerning climb at 124 KIAS and 170 KIAS / M 0.40
 are given in chapter 5.10
- 6 - EIS Check
- 7 - CAS display Check
- 8 - Weather radar As required
- 9 - Pressurization Check

Continue ►

Climb

2/2

► *Continuing*

A/C panel

- 10 - TEMP selector Adjust
- 11 - FUEL gages Check
Verify fuel quantity and imbalance, correct if necessary.
- 12 - AMPS / VOLTS Check

▲ CAUTION ▲

If heavy precipitation, turn IGNITION and INERT SEP switches to ON.



- 13 - DE ICE SYSTEM panel As required
Refer to chapter 4.5
 - 14 - INERT SEP switch As required
 - 15 - LDG lights As required
- End of procedure.*

Cruise	1/2
--------	-----

- 1 - Altimeters setting Check
- 2 - Autopilot Check
 Autopilot status and yaw damper ON

▲ CAUTION ▲

Observe TRQ / Ng / Np / ITT / OIL T° and PSI limitations.
 Use optimum torque and / or refer to tables in chapter 5.8.



- 3 - TRQ adjustment / ITT / Ng Check
 Adjust according to engine operation tables - chapter 5.8
 or to cruise index on the PFDs

● NOTE ●

Engine operation tables (chapter 5.8) give torque to be applied according to
 OAT, in order not to exceed authorized maximum power.
 When INERT SEP switch is OFF, a more accurate setting of torque must then
 be performed according to cruise performance tables presented in
 chapter 5.11.



- 4 - EIS Check
- 5 - CAS display Check
- 6 - Pressurization Check

Regularly check fuel gages for :

- 7 - Consumption
- 8 - Expected fuel at destination
- 9 - Tank automatic change every 5 minutes
- 10 - Imbalance
 Max. imbalance 15 USG

When the cruise parameters are stabilized, after 4 min minimum :

- 11 - AMPS / VOLTS Check

Continue ►

Cruise	2/2
--------	-----

► *Continuing*

▲ **CAUTION** ▲

If heavy precipitation, turn IGNITION and INERT SEP switches to ON.



- 12 - DE ICE SYSTEM panel As required
Refer to chapter 4.5
- 13 - INERT SEP switch As required
- 14 - LDG lights As required

End of procedure.

Before descent

- 1 - Briefing before approach Completed
- 2 - Altimeters settings Check
- 3 - Pressurization Check
- 4 - LFE Check
- 5 - FUEL gages Check
Check for quantity and imbalance
- 6 - Fullest tank Select
- 7 - AMPS / VOLTS Check

▲ CAUTION ▲

If heavy precipitation, turn IGNITION and INERT SEP switches to ON.



- 8 - DE ICE SYSTEM panel As required
Refer to chapter 4.5
- 9 - Windshield misting protection system As required

Prior to descent in moist conditions and to avoid canopy misting :

- 10 - HOT AIR FLOW distributor Set to 12 o'clock position
- 11 - WINDSHIELD switch ON

If misting continues :

- 12 - HOT AIR FLOW distributor Turn to the left
Or refer to chapter 3.11
paragraph Windshield misting or internal icing
- 13 - INERT SEP switch As required
End of procedure.

Approach

- 1 - Altimeters settings (QNH) Set / Check
- 2 - Minimums Set / Check
- 3 - COM / NAV / GPS Set / Check
- 4 - Pressurization Check
- 5 - LFE Check
- 6 - FUEL gages Check
Check for quantity and imbalance
- 7 - Fullest tank Select
- 8 - AMPS / VOLTS Check

▲ CAUTION ▲

If heavy precipitation, turn IGNITION and INERT SEP switch to ON.



- 9 - DE ICE SYSTEM panel As required
Refer to chapter 4.5

- 10 - Windshield misting protection system As required

Prior to descent in moist conditions and to avoid canopy misting :

- 11 - HOT AIR FLOW distributor Set to 12 o'clock position

- 12 - WINDSHIELD switch ON

If misting continues :

- 13 - HOT AIR FLOW distributor Turn to the left
Or refer to chapter 3.11
paragraph Windshield misting or internal icing

- 14 - INERT SEP switch ON

When below FL 100 :

- 15 - LDG lights ON

- 16 - Passenger's briefing As required

- 17 - Seats, belts, harnesses Locked

- 18 - Passenger's table Stowed

End of procedure.

Final approach (in GS) or downwind leg (VMC)

Long final :

- 1 - Altimeters Check
- 2 - FUEL gages Check
Check for quantity and imbalance
- 3 - Fullest tank Select
Maximum tolerated imbalance is 15 USG

When below FL 100 :

- 4 - LDG lights ON
- 5 - INERT SEP switch ON

When airspeed is below 178 KIAS :

- 6 - LANDING GEAR lever DN
- 7 - 3 green indicator lights Check ON
- 8 - GEAR UNSAFE red warning light Check OFF
- 9 - **GEAR UNSAFE** Check OFF
- 10 - Amber light Check OFF

• NOTE •

During the sequence :

- The amber caution light flashes. It indicates that the landing gear pump is running. It goes off when the 3 landing gears are down locked. GEAR UNSAFE red warning light ON and **GEAR UNSAFE** indicate an anomaly (refer to chapter 3.7 Emergency procedures).
- It is possible that the 3 landing gear position green indicator lights flash unevenly then come ON at the end of the sequence.

•

- 11 - FLAPS lever TO
Airspeed < 178 KIAS
- 12 - Radar Mode softkey STANDBY

End of procedure.

Short final (\approx 500 ft)*Stabilized approach*

- 1 - LANDING GEAR lever Check
DN and 3 green

When airspeed is below 122 KIAS :

- 2 - FLAPS lever LDG

• NOTE •

However, when autopilot is engaged, in APR mode, with coupled GS, FLAPS must be extended in landing position before crossing the OUTER MARKER.

•

Without AP engaged :

- 3 - Approach airspeed 85 KIAS

With AP engaged :

- 4 - Approach airspeed Above 85 KIAS

• NOTE •

This is to avoid any vertical deviation in case of late FLAPS extension to LDG position in short final.

•

- 5 - AP / YD Disconnect
Before 200 ft

• NOTE •

The pilot effort required to use the rudder pedals is reduced if the yaw damper is turned off. This is particularly significant when landing in a crosswind.

•

End of procedure.

Landing

▲ WARNING ▲

Reduce power smoothly.

Quickly reducing the power to idle during the flare may induce a pronounced deceleration which may lead to a drop down of the airplane.



1 - THROTTLE Flight IDLE

● NOTE ●

Avoid three-point landings. Adopt a positive flight attitude in order to touch runway first with main landing gear.



After wheels touch :

▲ CAUTION ▲

On snowy or dirty runway, it is better not to use reverse below 40 KIAS.



2 - Reverse As required
Reverse may be applied as soon as the wheels touch the ground

● NOTE ●

To avoid ingestion of foreign objects, come out of the reverse range as speed reduces and use the brakes if necessary for further deceleration.



● NOTE ●

High power reverse at low speed can throw loose material into the air, and can cause control problems and decrease the comfort of crew and passengers. If permitted by the runway length, it is better to adopt a moderate reverse.



3 - Brakes As required

● NOTE ●

It is advised not to brake energetically, as long as speed has not reached 40 KIAS, as otherwise wheels may be locked.



End of procedure.

Go-around with AP OFF**1/2**

- 1 - GO AROUND push-button Press
It provides the moving up of the flight director to + 10°.

Simultaneously :

- 2 - THROTTLE T/O power

• NOTE •

The airplane will tend to yaw to the left when power is applied. Right rudder pressure will be required to maintain coordinated straight flight until the rudder trim can be adjusted.

•

- 3 - Attitude 10° Up

- 4 - FLAPS lever TO

>> *Weight below 6579 lbs (2984 kg)*

If airspeed has been maintained at 80 KIAS or more and TRQ 100 %, select flaps to TO position as soon as the 10° Up attitude has been attained.

When the vertical speed is positive and when airspeed is at or above 85 KIAS :

- 5 - LANDING GEAR lever UP
All warning lights OFF

When airspeed is at or above 110 KIAS :

- 6 - FLAPS lever UP
7 - Climb airspeed As required

>> *Weight above 6579 lbs (2984 kg)*

If airspeed has been maintained at 85 KIAS or more and TRQ 100 %, select flaps to TO position as soon as the 10° Up attitude has been attained.

When the vertical speed is positive and when airspeed is at or above 90 KIAS :

- 8 - LANDING GEAR lever UP
All warning lights OFF

Continue ►

Go-around with AP OFF	2/2
-----------------------	-----

► *Continuing*

When airspeed is at or above 115 KIAS :

- 9 - FLAPS lever UP
- 10 - Climb airspeed As required

>> *All*

- 11 - TRQ As required

End of procedure.

Go-around with AP ON

- 1 - GO AROUND push-button Press
AP remains ON with the flight director moving up to + 10°.

Simultaneously :

- 2 - THROTTLE T/O power
3 - FLAPS lever TO

>> *Weight below 6579 lbs (2984 kg)*

If airspeed has been maintained at 80 KIAS or more and TRQ 100 %, select flaps to TO position as soon as the 10° Up attitude has been attained.

When the vertical speed is positive and when airspeed is at or above 85 KIAS :

- 4 - LANDING GEAR lever UP
All warning lights OFF

When airspeed is at or above 110 KIAS :

- 5 - FLAPS lever UP
6 - Climb airspeed As required

>> *Weight above 6579 lbs (2984 kg)*

If airspeed has been maintained at 85 KIAS or more and TRQ 100 %, select flaps to TO position as soon as the 10° Up attitude has been attained.

When the vertical speed is positive and when airspeed is at or above 90 KIAS :

- 7 - LANDING GEAR lever UP
All warning lights OFF

When airspeed is at or above 115 KIAS :

- 8 - FLAPS lever UP
9 - Climb airspeed As required

>> *All*

- 10 - TRQ As required

End of procedure.

Touch and go 1/2

Before wheels touch :

▲ WARNING ▲

Reduce power smoothly.

Quickly reducing the power to idle during the flare may induce a pronounced deceleration which may lead to a drop down of the airplane.



- 1 - Takeoff distances Checked
Refer to chapter 5.9
- 2 - Rotation airspeed (V_R) Checked

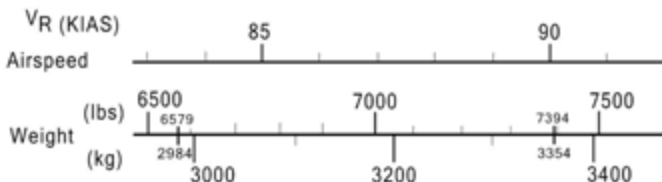
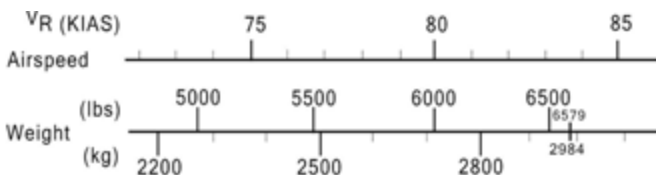

1010000AA11MAB000

After wheels touch :

- 3 - FLAPS lever TO
- 4 - Elevator trim Green sector
 It is faster to use manual elevator trim control than electric one.
 Ensure that runway length is sufficient to complete this sequence.

Continue ►

Touch and go

2/2

► *Continuing***▲ WARNING ▲**

Confirm that flaps have reached the TO position before increasing power. Do not increase power with full flaps, as airplane may lift off prematurely at low speed.



5 - THROTTLE T/O power

If normal takeoff :

6 - Attitude 10° Up

*If short takeoff :**Weight < 6579 lbs (2984 kg)*

7 - Attitude 15° Up

Weight > 6579 lbs (2984 kg)

8 - Attitude 12.5° Up

● NOTE ●

The POH does not supply distances for touch and go. The pilot must decide whether the runway length is sufficient.

*End of procedure.*

Runway clear

Runway clear - airplane stopped

▲ **CAUTION** ▲

Generator load < 200 amps



- 1 - TAXI lights ON
- 2 - NAV switch OFF
- 3 - STROBE switch OFF
- DE ICE SYSTEM panel :
- 4 - AIRFRAME DE ICE switch OFF
- 5 - PROP DE ICE switch OFF
- 6 - WINDSHIELD switch As required
- 7 - PITOT L HTR switch OFF
- 8 - PITOT R & STALL HTR switch OFF
- 9 - INERT SEP switch Check ON
- 10 - Trims Reset to takeoff position
- 11 - FLAPS lever UP
- 12 - A/C switch As required
- 13 - XPDR Check GND
- 14 - WX radar Check

Maintain WX radar on standby in order
not to generate radiations prejudicial to outside persons.
The WX radar is automatically set to standby after the touchdown.

End of procedure.

Shutdown	1/3
----------	-----

- 1 - PARK BRAKE Set ON
- 2 - **PARK BRAKE** Check ON
- 3 - EXT LIGHTS panel All OFF
- 4 - INT LIGHTS panel As required
- 5 - OXYGEN switch OFF
- 6 - FUEL SEL switch MAN
- 7 - AP / TRIMS switch OFF
- 8 - A/C switch OFF

■ >> *Airplane with seats heaters system (Post-MOD70-0588-25)*

- 9 - SEATS HTRS MASTER switch OFF

■ >> *All*

- 10 - BLEED switch OFF
- 11 - Check for cabin depressurization ($\Delta p = 0$ Psi).
- 12 - THROTTLE Flight IDLE
For 2 min

● NOTE ●

This allows the engine to stabilize at minimum obtainable ITT in order to minimize the likelihood of oil coking in the #3 bearing area.



- 13 - THROTTLE LO-IDLE
For 15 sec

● NOTE ●

Keep THROTTLE on LO-IDLE position for 15 sec minimum before shutting down engine.



- 14 - THROTTLE CUT OFF
- 15 - INERT SEP switch OFF
- 16 - Radar Mode Softkey OFF

Continue ►

Shutdown 2/3

► *Continuing*

Fuel system check

- 17 - **AUX BOOST PMP ON** Check ON
Wait for AUX BP operation to be heard to confirm that the AUX BP is functional.
- 18 - AUX BP switch OFF
- 19 - GENERATOR selector OFF
- When inertial separator is retracted, after approximately 40 sec :*
- 20 - SOURCE selector OFF
- 21 - Crash lever Pull down
- 22 - FUEL TANK SELECTOR OFF
- 23 - PARK BRAKE As required

▲ **CAUTION** ▲

In case of high OAT [above 35°C (95°F)], motoring for up to 30 seconds is required after engine shutdown to minimize oil coking and cool the engine bearings - refer to the Motoring procedure.



Shutdown stand-by instruments

MD302 normal shutdown procedure :

- 24 - No pilot action required for normal shutdown. The MD302 will shut down automatically within 60 seconds following electrical power shutdown.

MD302 manual shutdown procedure :

● NOTE ●

The MD302 can be manually shut down when in the discharge mode to conserve battery power.



- 25 - Press and hold the control knob for approximately 2 seconds.

Continue ►

Shutdown

3/3

▶ *Continuing*

- 26 - Turn the control knob to select POWER OFF on the menu and press the control knob to shut down the standby attitude module.

End of procedure.

Outside check after shutdown

- 1 - Oxygen cylinder (right wing fairing) Close
- 2 - Install air inlet and static port plugs, and exhaust and pitot covers.

• NOTE •

Be careful of exhaust stubs temperature before installing covers.

•

• NOTE •

15 to 20 minutes after the engine shutdown, check engine oil level.

Refer to chapter 8.7 : Oil level check.

•

End of procedure.

4.5 - Particular procedures

• NOTE •

The procedures and procedure elements given in this chapter Particular procedures supplement the normal procedures or complete certain elements of the normal procedures described in chapter(s) 4.3 and/or 4.4.



Flight into known icing conditions

1/5

▲ CAUTION ▲

The stall warning system does not function properly in icing conditions and should not be relied upon to provide adequate stall warning in icing conditions and after leaving icing conditions, if ice accretion remains on the airplane.

Moreover, the ESP and USP functions may not be correctly engaged.



General

Icing conditions exist when the OAT on the ground or in flight is + 5°C or below, and visible moisture in any form is present (clouds, fog with visibility of one mile (1.6 km) or less, rain, snow, sleet or ice crystals).

Icing conditions also exist when the OAT on the ground is + 5°C or below and when operating on ramps, taxiways or runways where surface snow, ice, standing water or slush may be ingested by the engine or freeze on engine or cowlings.

• NOTE •

Refer to figure 5.5.1 to convert OAT to SAT in flight.

SAT = OAT - 2°C on the ground.



Flight into known icing conditions is authorized when all airplane equipment provided for ice protection is operating correctly. This includes :

- Pneumatic deice system for inboard and outboard wing, for stabilizers and for elevator horns.
- Propeller electrical deice system.
- Electrical heating system for both pitots and for the stall warning incidence sensor.

Continue ►

Flight into known icing conditions 2/5

► *Continuing*

- Windshield electrical deice system.
- Inertial separator.

Description of deice systems is presented in chapter 7.13.

Ice accumulation thickness is monitored by the pilot on the L.H. wing leading edge.

At night, a leading edge icing inspection light located on the fuselage L.H. side, activated by the ICE LIGHT switch, is provided.

Boots are automatically cycling at the optimum time to assure proper ice removal. Correct operation of the system can be checked observing the corresponding green advisory light illumination at each boot inflation impulse. If correct operation cannot be confirmed, do not enter or leave as soon as possible icing conditions.

Perform emergency procedure Leading edges deicing failure, paragraph 3.11.

Ice protection procedures

▲ **CAUTION** ▲

Should conditions require it, apply these directives from beginning of taxi onwards.



Prior to entering IMC, as a preventive and if OAT < 5°C :

▲ **CAUTION** ▲

Inertial separator position affects engine parameters, particularly TRQ and ITT. Care must be exercised when operating the inertial separator or when increasing power with the inertial separator ON, to avoid exceeding engine limitations.



- 1 - INERT SEP switch ON
- 2 - IGNITION switch ON

● **NOTE** ●

IGNITION switch may be left ON for a long period.



Continue ►

Flight into known icing conditions

3/5

► *Continuing*

- 3 - **INERT SEP ON** Check ON
- 4 - AIRFRAME DE ICE switch ON
- 5 - PROP DE ICE switch ON
- 6 - WINDSHIELD switch ON

● NOTE ●

Standby compass indications are altered when windshield deicing system(s) operate(s).

●

When operating under IMC :

▲ CAUTION ▲

Inertial separator position affects engine parameters, particularly TRQ and ITT. Care must be exercised when operating the inertial separator or when increasing power with the inertial separator ON, to avoid exceeding engine limitations.

▲

- 7 - INERT SEP switch ON
- 8 - IGNITION switch ON

● NOTE ●

IGNITION switch may be left ON for a long period.

●

- 9 - **INERT SEP ON** Check ON
- 10 - AIRFRAME DE ICE switch ON
- 11 - PROP DE ICE switch ON

Continue ►

Flight into known icing conditions	4/5
------------------------------------	-----

► *Continuing*

12 - WINDSHIELD switch ON

• NOTE •

Standby compass indications are altered when windshield deicing system(s) operate(s).

•

• NOTE •

The INERT SEP switch must be left ON while the airplane remains in icing conditions.

•

▲ CAUTION ▲

If airplane leaves icing conditions, maintain INERT SEP switch to ON as long as ice thickness on non-deiced visible parts exceeds 15 mm (or 1/2 in).

▲

This will avoid ice fragments coming from propeller spinner and being ingested by engine.

Procedures for holding, approach and landing in icing conditions :

- Minimum recommended airspeeds are :

	Weight	
	< 6579 lbs (2984 kg)	> 6579 lbs (2984 kg)
FLAPS UP	130 KIAS	135 KIAS
FLAPS TO	110 KIAS	115 KIAS
FLAPS LDG	90 KIAS	95 KIAS

- If there is ice on the unprotected surfaces of the airplane, during flight end phase, conduct holding with the flaps up. Use flaps as required for final approach and landing at minimum airspeeds noted above.

Continue ►

Flight into known icing conditions

5/5

► *Continuing***Ice accumulation effects**

When ice has accumulated on the unprotected surfaces of the airplane, aerodynamic characteristics may be changed.

Particularly stall airspeeds may increase by up to :

FLAPS UP	20 KIAS
FLAPS TO	15 KIAS
FLAPS LDG	10 KIAS

In case of severe or prolonged icing, an ice concretion due to refreezing around the heated stall warning may appear. Above-recommended airspeeds take into account, on one side, the stall airspeed increase due to profile shape deterioration and, on the other side, the weight increase of the iced-up airplane, taking as a basis the airplane maximum weight when not iced-up.

Rate of climb values with ice accumulation on the unprotected surfaces are to be decreased by 10 %.

Cruise airspeeds may be decreased by 10 %, if cruise power is not changed, or more, if cruise power setting should be decreased due to the additional inertial separator limitations (ITT limitation).

Because of the higher landing airspeed, landing distances will be increased. In the landing configuration, using 90 KIAS approach airspeed increases landing distance by 20 % - refer to chapter 5.14 Landing distances.

End of procedure.

Flight into severe icing conditions

The following weather conditions may be conducive to severe in-flight icing :

- Visible rain at temperatures below 0°C ambient air temperature,
- Droplets that splash or splatter on impact at temperatures below 0°C ambient air temperature.

Procedures for exiting the severe icing environment

● NOTE ●

These procedures are applicable to all flight phases from takeoff to landing.



Monitor the ambient air temperature. While severe icing may form at temperatures as cold as - 18°C, increased vigilance is warranted at temperatures around freezing with visible moisture present. If the visual cues specified in section 2 Limitations for identifying severe icing conditions are observed, accomplish the following :

- 1 - Immediately request priority handling from Air Traffic Control to facilitate a route or an altitude change to exit the severe icing conditions in order to avoid extended exposure to flight conditions more severe than those for which the airplane has been certificated.
- 2 - Avoid abrupt and excessive maneuvering that may exacerbate control difficulties.
- 3 - Do not engage the autopilot.

If the autopilot is engaged :

- 4 - Hold the control wheel firmly and disengage the autopilot.

If an unusual roll response or uncommanded roll control movement is observed :

- 5 - Angle-of-attack Reduce
- 6 - Do not extend flaps when holding in icing conditions. Operation with flaps extended can result in a reduced wing angle-of-attack, with the possibility of ice forming on the upper surface further aft on the wing than normal, possibly aft of the protected area.

If the flaps are extended :

- 7 - Do not retract them until the airframe is clear of ice.
- 8 - Report these weather conditions to Air Traffic Control.

End of procedure.

Flight under heavy precipitations

- 1 - IGNITION switch ON

• NOTE •

This action is intended, in highly improbable case of an engine flame-out further to an important ingestion, to ensure immediate restarting without action of the pilot.

•

- 2 - INERT SEP switch ON

End of procedure.

Utilization on runways covered with water

If takeoff or landing must be performed on a runway covered with water :

- 1 - IGNITION switch ON

- 2 - INERT SEP switch ON

End of procedure.

Utilization on runways covered with melting
or not tamped snow

1/3

If required :

Refer to paragraph Utilization by cold weather and very cold weather.

▲ CAUTION ▲

When engine is shut down, do not set the PROP DE ICE switch to ON for more than 10 seconds, damage to the propeller blades could result.



Preflight inspection :

- 1 - Remove any snow or ice from the wings, stabilizers and movable surfaces, landing gear wells and gear doors, as well as flap tracks, actuators and their fairings.
- 2 - Spray anti-icing fluid on the wings, stabilizers and movable surfaces (upper and lower surfaces) and in the landing gear wells, shortly before takeoff.

Taxiing :

- 3 - INERT SEP switch ON
- 4 - **INERT SEP ON** Check ON
- 5 - FLAPS lever UP
- 6 - Taxi airspeed Max. 5 KIAS
- 7 - Brakes Apply occasionally
To maintain the brake pads warm, this will prevent any subsequent locking due to freezing after takeoff

Before line up :

If the runway is long enough :

- 8 - FLAPS lever UP

Continue ►

Utilization on runways covered with melting
or not tamped snow 2/3

► *Continuing*

- 9 - Rotation airspeed Increased by 5 KIAS

• NOTE •

Takeoff distances must be increased to take into account the flap position (+ 15 % compared to the takeoff position) and the runway condition.

The ground roll may be multiplied by 3 in some melting or not tamped snow cases.

•

- 10 - IGNITION switch ON
- 11 - INERT SEP switch ON
- 12 - **INERT SEP ON** Check ON

Takeoff :

During takeoff run :

- 13 - Lightly lift up nose wheel
In order to reduce the forward resistance due to snow accumulation against the wheel.

After takeoff :

- 14 - Normally retract the landing gear, then perform a complete cycle (extension / retraction) at IAS < 150 KIAS.

Before landing :

- 15 - IGNITION switch ON
- 16 - INERT SEP switch ON
- 17 - **INERT SEP ON** Check ON

Continue ►

Utilization on runways covered with melting
or not tamped snow

3/3

► *Continuing*

Touch and Go :

▲ WARNING ▲
Touch and Go is prohibited.



On the ramp, after landing or taxiing :

- 18 - Do not use the parking brake to prevent brake lock.
- 19 - Use chocks and / or tie-down the airplane.

End of procedure.

Utilization on icy or covered with tamped snow runways 1/2

If required :

Refer to paragraph Utilization by cold weather and very cold weather.

▲ CAUTION ▲

When engine is shut down, do not set the PROP DE ICE switch to ON for more than 10 seconds, damage to the propeller blades could result.



Preflight inspection

- 1 - Remove any snow or ice from the wings, stabilizers and movable surfaces, landing gear wells and gear doors, as well as flap tracks, actuators and their fairings.
- 2 - Spray anti-icing fluid on the wings, stabilizers and movable surfaces (upper and lower surfaces), shortly before takeoff.

Taxiing :

- 3 - INERT SEP switch ON
- 4 - **INERT SEP ON** Check ON
- 5 - Taxi airspeed Max. 5 KIAS
Use β area of THROTTLE to adjust airspeed
Apply very smooth variations using THROTTLE
- 6 - Steer the airplane using the rudder.

● NOTE ●

Make turns at a very low airspeed, engine torque tends to make the airplane turn to the left.



- 7 - Use brakes only at very low airspeed and progressively.

Before line up :

- 8 - IGNITION switch ON
- 9 - INERT SEP switch ON
- 10 - **INERT SEP ON** Check ON

Continue ►

Utilization on icy or covered with tamped snow runways 2/2

► *Continuing*

Takeoff :

- 11 - After takeoff, normally retract the landing gear, then perform a complete cycle (extension / retraction) at IAS < 150 KIAS.

Before landing :

- 12 - IGNITION switch ON
- 13 - INERT SEP switch ON
- 14 - **INERT SEP ON** Check ON

Landing :

After wheels touch

- 15 - Use reverse only if necessary and very progressively by monitoring the airplane behaviour.

● NOTE ●

The engine torque tends to make the airplane turn to the left.

●

- 16 - Taxi airspeed Max. 5 KIAS
Use β area of THROTTLE to adjust airspeed
Apply very smooth variations using THROTTLE

- 17 - Steer the airplane using the rudder.

● NOTE ●

Make turns at a very low airspeed, engine torque tends to make the airplane turn to the left.

●

- 18 - Use brakes only at very low airspeed and progressively.

On the ramp, after landing or taxiing :

- 19 - Do not use the parking brake to prevent brake lock.
- 20 - Use chocks and / or tie-down the airplane.

End of procedure.

Utilization by cold weather (- 0°C to - 25°C) and very cold weather (- 25°C to - 40°C)

• NOTE •

The procedure hereafter supplements the normal procedures for the airplane use when operating under temperatures between 0°C and - 40°C on ground.

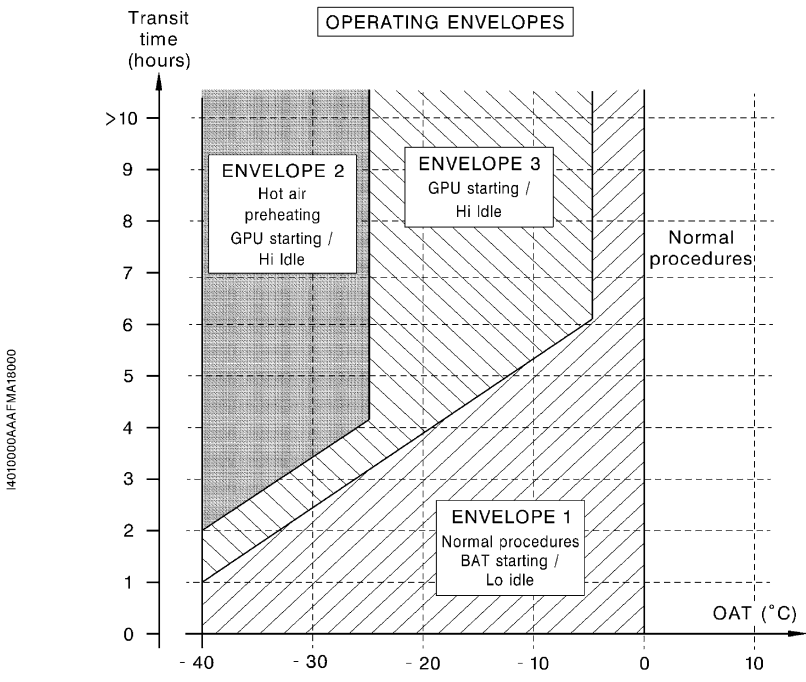

Figure 4.5.1 - Operating envelopes by cold weather (- 0°C to - 25°C) and very cold weather (- 25°C to - 40°C)

End of procedure.

Utilization by cold weather (- 0°C to - 25°C) and very cold weather (- 25°C to - 40°C) - Envelope 1 1/3

• NOTE •

The procedure hereafter supplements the normal procedures for the airplane use when operating in the Envelope 1 defined in figure 4.5.1.



Preflight inspection :

- 1 - Remove any snow or ice from the wings, stabilizers and movable surfaces.

According to the condition of runways and taxiways

- 2 - Perform procedure Utilization on runways covered with melting or not tamped snow
Refer to chapter 4.5

or

- 3 - Perform procedure Utilization on icy or covered with tamped snow runways
Refer to chapter 4.5

- 4 - Carry out a complete rotation of the propeller to check its free rotation.
- 5 - Do not perform a fuel draining. If the airplane is operating permanently under negative temperatures, drainings will have to be performed once a week after having parked the airplane in a heated hangar.
- 6 - Remove chocks and / or release ties from the airplane.
- 7 - Check the free deflection of the flight controls and of the elevator trim.
- 8 - Check the free deflection of THROTTLE.

Before starting engine / Engine start / After engine start :

- 9 - Perform normal procedures defined in chapter(s) 4.3 and / or 4.4.

Before taxiing / Taxiing / Before line up / Takeoff :

DE ICE SYSTEM panel

- 10 - INERT SEP switch ON
- 11 - **INERT SEP ON** Check ON

Continue ►

Utilization by cold weather (- 0°C to - 25°C) and very cold weather (- 25°C to - 40°C) - Envelope 1	2/3
-----------------------------------------------------------------------------------------------------	-----

► *Continuing*

- 12 - PITOT L HTR switch ON
- 13 - PITOT R & STALL HTR switch ON
- 14 - PROP DE ICE switch ON

15 - Perform normal procedures defined in chapter(s) 4.3 and / or 4.4.
According to the condition of runways and taxiways

- 16 - Perform procedure Utilization on runways covered with melting or not tamped snow
Refer to chapter 4.5

or

- 17 - Perform procedure Utilization on icy or covered with tamped snow runways
Refer to chapter 4.5

Landing / After landing :

18 - Perform normal procedures defined in chapter(s) 4.3 and / or 4.4.
According to the condition of runways and taxiways

- 19 - Perform procedure Utilization on runways covered with melting or not tamped snow
Refer to chapter 4.5

or

- 20 - Perform procedure Utilization on icy or covered with tamped snow runways
Refer to chapter 4.5

Shutdown :

- 21 - PARK BRAKE OFF

Continue ►

Utilization by cold weather (- 0°C to - 25°C) and very cold weather (- 25°C to - 40°C) - Envelope 1 3/3

► *Continuing*

22 - **PARK BRAKE** Check OFF

• NOTE •

Use of the parking brake in cold or very cold weather is not recommended in order to prevent the brakes from sticking.

•

23 - Perform normal procedures defined in chapter(s) 4.3 and / or 4.4.

24 - Use chocks and / or tie-down the airplane using anchor points on ground.

25 - Install air inlet and static port plugs, and exhaust and pitot covers.

End of procedure.

Utilization by cold weather (- 0°C to - 25°C) and very cold weather (- 25°C to - 40°C) - Envelope 2	1/5
-----------------------------------------------------------------------------------------------------	-----

● NOTE ●

The procedures hereafter supplement or replace the normal procedures for the airplane use when operating in the Envelope 2 defined in figure 4.5.1.



Preflight inspection :

- 1 - Preheat the engine and the cabin.

● NOTE ●

Preheating during at least 30 minutes is necessary using a heater (70°C mini). Hot air pipes must be installed in the air inlet, on engine rear table by opening the upper cowling and in the cabin by half-opening the door.



- 2 - Remove any snow or ice from the wings, stabilizers and movable surfaces.

According to the condition of runways and taxiways

- 3 - Perform procedure Utilization on runways covered with melting or not tamped snow
Refer to chapter 4.5

or

- 4 - Perform procedure Utilization on icy or covered with tamped snow runways
Refer to chapter 4.5

- 5 - Spray anti-icing fluid on the wings, stabilizers and movable surfaces (upper and lower surfaces), shortly before takeoff.

- 6 - Carry out a complete rotation of the propeller to check its free rotation.

- 7 - Do not perform a fuel draining. If the airplane is operating permanently under negative temperatures, drainings will have to be performed once a week after having parked the airplane in a heated hangar.

- 8 - Remove chocks and / or release ties from the airplane.

- 9 - Check the free deflection of the flight controls and of the elevator trim.

- 10 - Check the free deflection of THROTTLE.

Continue ►

Utilization by cold weather (- 0°C to - 25°C) and very cold weather (- 25°C to - 40°C) - Envelope 2 2/5

► *Continuing*

11 - IGNITION switch ON during 30 seconds

12 - **IGNITION** Check ON

Then :

13 - IGNITION switch AUTO

14 - **IGNITION** Check OFF

• NOTE •

This enables to preheat spark igniters before starting the engine.

•

Before starting the engine :

15 - Perform normal procedures defined in Chapter(s) 4.3 and / or 4.4.

Engine start :

▲ CAUTION ▲

The starting must be mandatorily performed using an external power source (GPU).



16 - Ground power unit Connected

17 - SOURCE selector GPU

18 - **GPU DOOR** Check ON

19 - Battery and ESS. bus VOLTS Check voltage ≈ 28 Volts
On EIS of MFD

Engine controls

20 - MAN OVRD control Full backward (notched)

Continue ►

Utilization by cold weather (- 0°C to - 25°C) and very cold weather (- 25°C to - 40°C) - Envelope 2 3/5

► *Continuing*

▲ **CAUTION** ▲

When the engine is shut down, the THROTTLE must not be moved into the reverse area.



- 21 - THROTTLE CUT OFF
- FUEL panel
- 22 - AUX BP switch ON
- 23 - **AUX BOOST PMP ON** Check ON
- 24 - **FUEL PRESS** Check OFF
- 25 - Propeller area Clear
- ENGINE START panel
- 26 - IGNITION switch ON
- 27 - **IGNITION** Check ON
- 28 - STARTER switch ON
2 sec then OFF
- Simultaneously :*
- 29 - Timer Start
- 30 - **STARTER** Check ON
- When Ng ≈ 13 % :*
- 31 - THROTTLE HI-IDLE
Move directly THROTTLE to HI-IDLE

● **NOTE** ●

The more the temperature is low, the more the selector is hard to move.
Starter limits and checks of starting sequence are unchanged.



Continue ►

Utilization by cold weather (- 0°C to - 25°C) and very cold weather (- 25°C to - 40°C) - Envelope 2 4/5

► *Continuing*

When Ng > 50% :

▲ **CAUTION** ▲

If the starter does not go off automatically, disengage it using the ABORT position of the STARTER switch.



- 32 - Starter Check OFF automatically
- 33 - **STARTER** Check OFF
- 34 - Engine parameters Check
Ng = 70 % ± 2 %
Oil pressure and ITT in green sector
- 35 - SOURCE selector BATT
- 36 - **BAT OFF** Check OFF
- 37 - IGNITION switch AUTO
- 38 - **IGNITION** Check OFF
- 39 - Ground power unit Disconnect
- 40 - GPU door Close
- 41 - **GPU DOOR** Check OFF
- FUEL panel
- 42 - AUX BP switch AUTO
- 43 - **AUX BOOST PMP ON** Check OFF
- 44 - GENERATOR selector MAIN
- 45 - **MAIN GEN** Check OFF
Reset if necessary

Continue ►

Utilization by cold weather (- 0°C to - 25°C) and very cold
weather (- 25°C to - 40°C) - Envelope 2 5/5

► *Continuing*

After engine start :

As soon as the current flow is lower than 100 A :

A/C panel

- 46 - A/C switch PILOT
- 47 - TEMP selector Max warm
- 48 - FAN speed selector 0

PRESSURIZATION panel

- 49 - BLEED switch AUTO or MAX DIFF

As soon as the oil temperature is greater than 0°C :

- 50 - THROTTLE FEATHER twice
Flight IDLE to LO-IDLE, then Flight IDLE twice
- 51 - Perform normal procedures defined in chapter(s) 4.3 and / or 4.4.

Before taxiing / Taxiing / Before line up / Takeoff :

- 52 - Perform procedures defined for Envelope 1.

Landing / After landing / Shutdown :

- 53 - Apply procedures defined for Envelope 1.

End of procedure.

Utilization by cold weather (- 0°C to - 25°C) and very cold weather (- 25°C to - 40°C) - Envelope 3 1/2

• NOTE •

The procedures defined for the Envelope 2 are also applicable for the Envelope 3. However it is possible to start the engine using GPU without preheating of the engine and the cabin with a heater. In that case follow the procedure hereafter.



Preflight inspection / Before starting the engine / Engine start :

- 1 - Apply the procedures defined for the Envelope 2.

After engine start :

As soon as the current flow is lower than 100 A :

A/C panel

- 2 - A/C switch PILOT
- 3 - TEMP selector Max warm
- 4 - FAN airspeed selector 0

PRESSURIZATION panel

- 5 - BLEED switch AUTO or MAX DIFF
- 6 - Preheat the cabin respecting time defined in figure 4.5.2.
Before switching on the navigation and monitoring systems. This allows to respect minimum temperatures necessary for the equipment operation.

As soon as the oil temperature is greater than 0°C :

- 7 - THROTTLE FEATHER twice
Flight IDLE to LO-IDLE, then Flight IDLE twice
- 8 - Perform normal procedures defined in chapter(s) 4.3 and / or 4.4.

Taxiing / Before line up / Takeoff /

- 9 - Perform procedures defined for Envelope 1.

Continue ►

Utilization by cold weather (- 0°C to - 25°C) and very cold weather (- 25°C to - 40°C) - Envelope 3 2/2

► *Continuing*

Landing / After landing / Shutdown /

10 - Perform procedures defined for Envelope 1.

● NOTE ●

If landing is foreseen by cold or very cold weather, or in case of prolonged operation of the airplane in such conditions, it is recommended to prepare the airplane as specified in chapter 8.10.

●

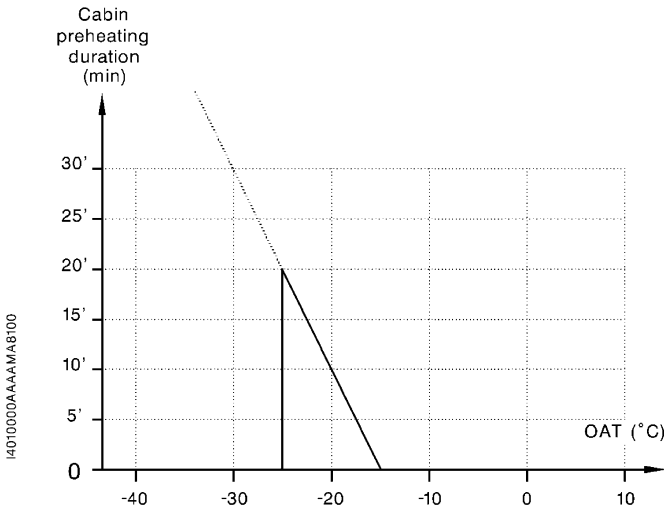

Figure 4.5.2 - Preheating duration

End of procedure.

Landing procedure with strong headwind or crosswind 1/2

If landing must be performed with strong headwind or crosswind :

1 - Increase approach airspeed by the greatest of these 2 following values :

- $\Delta V = \frac{(\text{headwind} - 10)}{2}$ (Ex. headwind = 30 kt i.e. $\Delta V = 10$ kt)
- Gust amplitude = wind gust - steady wind (Ex. for wind 20G35, Gust amplitude = 15 kt)

2 - FLAPS lever LDG

• NOTE •

Do not set the flaps in the TO position. Lateral control is not improved, and flare phase is lengthened in time and in distance, with increase of piloting difficulties and landing performance.

During approach with crosswind :

▲ CAUTION ▲

Do not use or select the fuel tank on the low wing side during prolonged sideslips with a fuel low warning or gauge indicating low.

▲ CAUTION ▲

Maximum sideslip duration is 30 seconds.

3 - Maintain the airplane in drift correction through the last possible moment until beginning the flare.

In short final, on a short runway :

- 4 - Use normal approach airspeed IAS = 85 KIAS
- 5 - FLAPS lever LDG
To avoid an excessive airspeed

• NOTE •

Excessive speed will increase landing distance beyond the distance indicated in chapter 5.14.

Continue ►

Landing procedure with strong headwind or crosswind 2/2▶ *Continuing**Before touch-down :*

- 6 - Generate a slideslip with the rudder in order to align fuselage with the runway (ie left crosswind, left wing low).

*Immediately after landing :***▲ CAUTION ▲**

Do not try to stabilize the airplane by pushing down the elevator control just after the touch ; this operation may provide pitch oscillations while increasing the yaw movement to the wind.

Do not deflect ailerons into wind while taxiing. This will raise spoilers and have a detrimental effect. A good solution is to maintain ailerons to neutral position during taxiing after landing and taxiing before takeoff.



- 7 - FLAPS lever UP

● NOTE ●

Flaps travel is slow and will not have an appreciable effect on landing performance.



Maximum demonstrated crosswind for landing is 20 kt.

The most restrictive situation is as follows :

- takeoff with wind coming from the left,
- wet runway,
- aft C.G.

End of procedure.

Utilization on grass runway 1/2

▲ CAUTION ▲

The small wheels of the airplane and its weight may lead it to sink in soaked or soft ground.



Before planning the landing, ensure that the field is hard, smooth and dry enough. Landing and moreover takeoff shall not begin if any doubt exists about the condition of such a runway.

Particular directives

Taxi / Takeoff :

1 - INERT SEP switch ON

2 - **INERT SEP ON** Check ON

▶ Do not use the reverse ◀

● NOTE ●

In fact, on a flat runway with grass, it is necessary to adopt a power greater than the one obtained when the THROTTLE is set to Flight IDLE, so the pilot will not be tempted to use the reverse.



End of procedure ■

Landing :

3 - INERT SEP switch ON

4 - **INERT SEP ON** Check ON

After wheels touch down :

5 - Reverse Only if necessary

▲ CAUTION ▲

Do not maintain reverse at airspeeds below 40 KIAS to avoid ingestion of foreign matter.



Continue ▶

Utilization on grass runway

2/2

► *Continuing*

• NOTE •

Under 40 KIAS, using the reverse makes a cloud of solid particles (dusts, sand, gravels, cut grass, ...) appear around the front face of the airplane. This will damage the propeller and, after ingestion, the engine internal components (compressor and turbine blades).

•

End of procedure.

GPS navigation

Set up conditions

- 1 - Verify if the data base is current.
- 2 - Verify that altitude data is valid for the GPS prior to flight.

Check the systems availability requirements in the table 2.6.1 in section 2 / GNSS (GPS/SBAS) navigation equipment approvals, depending on the planned navigation performance.

GPS flight plan

In the active flight plan, addition of a STAR or an approach is always made at the end of the flight plan. In the scope of these additions, the pilot must pay attention not to duplicate points.

End of procedure.

Section 5

Performance

Table of contents

5.1	-	General	5.1.1
5.2	-	Noise level	5.2.1
5.3	-	Airspeed calibration	5.3.1
5.4	-	Cabin pressurization envelope	5.4.1
5.5	-	SAT - OAT conversions	5.5.1
5.6	-	Stall speeds	5.6.1
5.7	-	Wind components	5.7.1
5.8	-	Engine operation	5.8.1
		Maximum climb power (FL < 200) - 124 KIAS	5.8.4
		Maximum climb power (FL > 200) - 124 KIAS	5.8.5
		Maximum climb power (FL < 200) - 170 KIAS / M 0.40	5.8.6
		Maximum climb power (FL >200) - 170 KIAS / M 0.40	5.8.7
		Maximum cruise power (FL < 200)	5.8.8
		Maximum cruise power (FL > 200)	5.8.9
		Normal (recommended) cruise power (FL < 200)	5.8.10
		Normal (recommended) cruise power (FL > 200)	5.8.11
5.9	-	Takeoff distances	5.9.1
		Weight : 5512 lbs (2500 kg)	5.9.2
		Weight : 6579 lbs (2984 kg)	5.9.3
		Weight : 7394 lbs (3354 kg)	5.9.4

5.10	-	Climb performance	5.10.1
		MXCL - Speeds (IAS = 124 KIAS)	5.10.1
		MXCL - Speeds (IAS = 170 KIAS / M 0.40)	5.10.2
		MXCL - Time, consumption and climb distance (IAS = 124 KIAS)	5.10.3
		MXCL - Time, consumption and climb distance (IAS = 170 KIAS / M 0.40)	5.10.6
		Climb performance after go-around	5.10.9
		Climb performance - Flaps TO	5.10.10
5.11	-	Cruise performance	5.11.1
		Maximum cruise	5.11.1
		Normal cruise (Recommended)	5.11.9
		Long range cruise (5500 lbs - 2495 kg)	5.11.17
		Long range cruise (6300 lbs - 2858 kg)	5.11.19
		Long range cruise (7100 lbs - 3220 kg)	5.11.21
5.12	-	Time, consumption and descent distance	5.12.1
5.13	-	Holding time	5.13.1
5.14	-	Landing distances	5.14.1
		Weight : 7024 lbs (3186 kg)	5.14.2
		Weight : 6250 lbs (2835 kg)	5.14.3
		Weight : 5071 lbs (2300 kg)	5.14.4

5.1 - General

This section provides all of the required and additional performance data for airplane operations.

The section 9, Supplements of the POH, provides specific airplane performance associated with optional equipment and systems.

Intentionally left blank

5.2 - Noise level

	Maximum noise level permitted	Demonstrated noise level
FAR PART 36, Appendix G - Amdt 28	88 dB(A)	76.4 dB(A)
ICAO, Annex 16, Vol. 1, 6th edition, Amdt 8 Chapter 10, Appendix 6	85 dB(A)	76.4 dB(A)

Approved noise levels for TBM airplane are stated in EASA.A.010 Type Certificate Data Sheet.

● NOTE ●

No determination has been made by the Federal Aviation Administration that the noise levels of this airplane are or should be acceptable or unacceptable for operation at, into or out of any airport.

●

Intentionally left blank

5.3 - Airspeed calibration

• NOTE •

Indicated airspeeds (IAS) : instrument error supposed to be null (power configuration for cruise condition flight).

•

Flaps UP LDG GR UP		Flaps TO LDG GR DN		Flaps LDG LDG GR DN	
KIAS	KCAS	KIAS	KCAS	KIAS	KCAS
125	128	70	69	60	58
150	154	80	80	70	68
175	179	90	90	80	78
200	205	100	101	90	88
225	230	120	121	100	98
250	255	140	141	110	108
266	271	160	162	120	118
MPH IAS	MPH CAS	MPH IAS	MPH CAS	MPH IAS	MPH CAS
144	147	81	79	69	67
173	177	92	92	81	78
201	206	104	104	92	90
230	236	115	116	104	101
259	264	138	139	115	113
288	293	161	162	127	124
307	312	184	187	138	136

Figure 5.3.1 - Normal static source

Flaps UP LDG GR UP		Flaps TO LDG GR DN		Flaps LDG LDG GR DN	
KIAS	KCAS	KIAS	KCAS	KIAS	KCAS
125	124	70	70	60	59
150	149	80	80	70	69
175	174	90	90	80	79
200	199	100	100	90	90
225	224	120	120	100	100
250	249	140	139	110	110
271	270	160	159	120	120
MPH IAS	MPH CAS	MPH IAS	MPH CAS	MPH IAS	MPH CAS
144	142	81	81	69	68
173	171	92	92	81	79
201	200	104	104	92	91
230	229	115	115	104	104
259	258	138	138	115	115
288	287	161	160	127	127
312	311	184	183	138	138

Figure 5.3.2 - Alternate static source (Bleed auto)

5.4 - Cabin pressurization envelope

• NOTE •

The cabin pressurization envelope below characterizes the cabin altitude that could be sustained by the fuselage at different flight levels. The curve shows the minimum cabin altitude as a function of flight level, corresponding to the maximum differential pressure. The maximum differential pressure is limited by the pressurization system protection function.

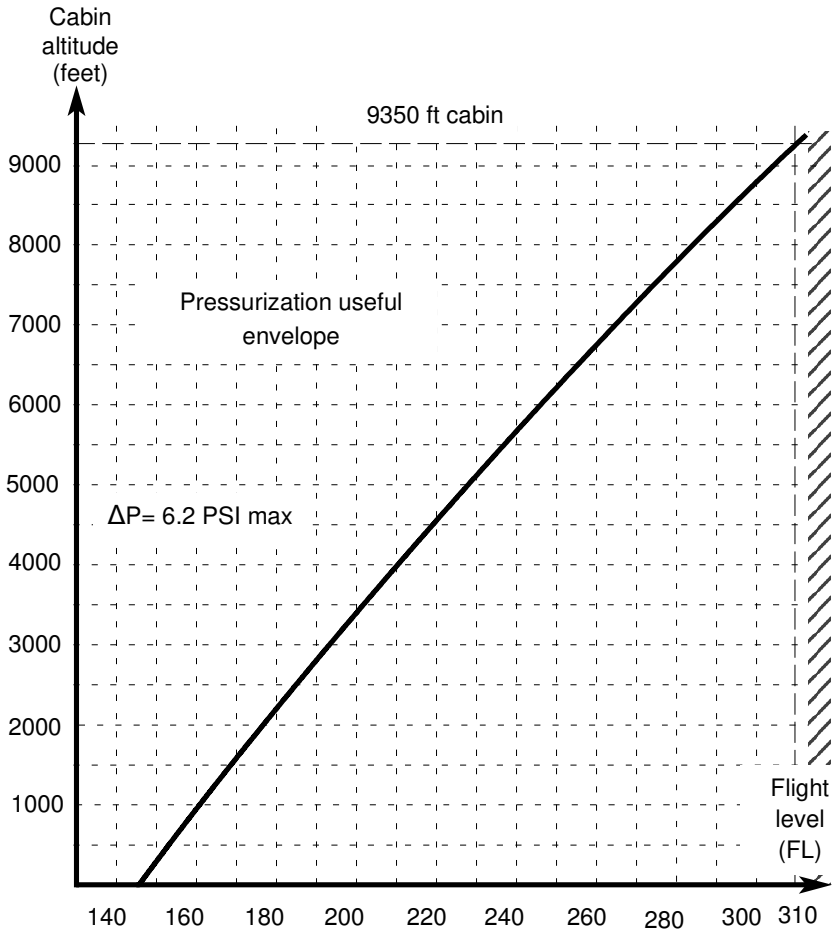

Figure 5.4.1 - Cabin pressurization envelope

Intentionally left blank

5.5 - SAT - OAT conversions

• NOTE •

These indicated temperatures are available for stabilized cruise at normal operating power.

•

Pressure altitude (feet)	ISA - 20°C		ISA - 10°C		ISA		ISA + 10°C		ISA + 20°C	
	SAT	OAT	SAT	OAT	SAT	OAT	SAT	OAT	SAT	OAT
SL	-05	-04	05	06	15	16	25	26	35	36
2000	-09	-08	01	02	11	12	21	22	31	32
4000	-13	-12	-03	-02	07	08	17	18	27	28
6000	-17	-16	-07	-06	03	04	13	14	23	24
8000	-21	-20	-11	-10	-01	00	09	10	19	20
10000	-25	-24	-15	-14	-05	-04	05	06	15	16
12000	-29	-28	-19	-18	-09	-08	01	02	11	12
14000	-33	-32	-23	-22	-13	-12	-03	-02	07	08
16000	-37	-36	-27	-26	-17	-16	-07	-06	03	04
18000	-41	-40	-31	-30	-21	-20	-11	-10	-01	00
20000	-45	-44	-35	-34	-25	-24	-15	-14	-05	-04
22000	-49	-48	-39	-38	-29	-28	-19	-18	-09	-08
24000	-53	-52	-43	-42	-33	-32	-23	-22	-13	-12
26000	-57	-56	-47	-46	-37	-36	-27	-26	-17	-16
28000	-61	-60	-51	-50	-41	-40	-31	-30	-21	-20
30000	-65	-64	-55	-54	-45	-44	-35	-34	-25	-24
31000	-67	-66	-57	-56	-47	-46	-37	-36	-27	-26

Figure 5.5.1 - SAT - OAT conversions

Intentionally left blank

5.6 - Stall speeds

Airplane weight	Config.		Bank											
	Flight idle		0°			30°			45°			60°		
	LDG GR	Flaps	KIAS	KCAS	MPH IAS	KIAS	KCAS	MPH IAS	KIAS	KCAS	MPH IAS	KIAS	KCAS	MPH IAS
4850 lbs (2200 kg)	UP	UP	65	66	75	70	71	81	78	79	90	91	93	105
	DN	TO	62	63	71	67	68	77	73	75	84	87	89	100
	DN	LDG	53	53	61	57	57	66	63	63	73	75	75	86
5512 lbs (2500 kg)	UP	UP	70	71	81	75	76	86	82	84	94	98	100	113
	DN	TO	66	67	76	71	72	82	78	80	90	93	95	107
	DN	LDG	57	57	66	61	61	70	68	68	78	81	81	93
6579 lbs (2984 kg)	UP	UP	75	76	86	80	82	92	88	90	101	105	107	121
	DN	TO	71	72	82	75	77	86	84	86	97	100	102	115
	DN	LDG	61	61	70	66	66	76	73	73	84	86	86	99
7394 lbs (3354 kg)	UP	UP	81	83	93	88	89	101	97	99	112	119	117	137
	DN	TO	77	77	89	81	83	93	91	92	105	108	109	124
	DN	LDG	65	65	75	69	70	79	76	77	88	92	92	106

Figure 5.6.1 - Stall speeds

Intentionally left blank

5.7 - Wind components

Example : Angle between wind direction and flight path : 50°
 Headwind : 8 kts
 Crosswind : 10 kts
 Wind speed : 13 kts

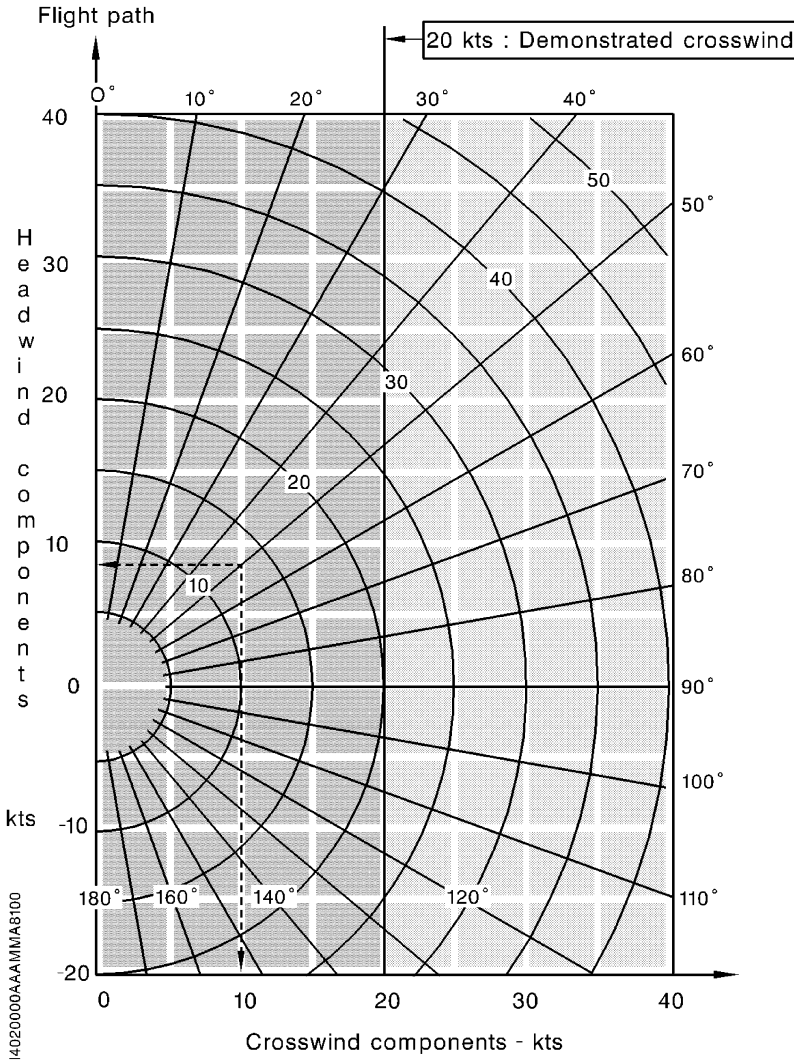

Figure 5.7.1 - Wind components

Intentionally left blank

Pilot's Operating Handbook

5.8 - Engine operation

The following tables or/and the optimum torque indicator must be used during normal operation of the airplane.

▲ CAUTION ▲

It is the responsibility of the operator to make sure that the required version of GARMIN system software is installed prior to using the hereafter engine operation tables.

The GARMIN system software required for this revision of the engine operation tables is the version 0719.14 or later.

This information is displayed on the MFD power-up page upon system start.

**▲ CAUTION ▲**

The TRQ setting must never exceed 100 %.
When setting TRQ, Ng must never exceed 104 %.



The following conditions are given for all the tables (pages 5.8.4 to 5.8.11) :

● NOTE ●

Inertial separator must be OFF and BLEED HI msg OFF.



- Landing gear and flaps UP.
- BLEED switch on AUTO.
-  represent the ISA conditions at the flight level.

The torque must be set at or below the value corresponding to the local conditions of flight level and temperature.

● NOTE ●

The engine ITT limit at 840°C during continuous operation may be used in case of operational need.



Example, for conditions :

- FL = 260
- OAT = - 22°C

the following tables give the maximum torque to be set.

Maximum climb power

TRQ setting = 83 % for IAS = 124 KIAS (Add 0.5 % of TRQ for each additional 10 KIAS on climb airspeed), cf. tables figures 5.8.1 and 5.8.1A

Maximum cruise power

TRQ setting = 97 %, cf. tables figures 5.8.3 and 5.8.3A

Recommended cruise power

TRQ setting = 92 %, cf. tables figures 5.8.4 and 5.8.4A

Intentionally left blank

Maximum climb power (FL < 200) - 124 KIAS

Conditions : If BLEED HI msg ON, reduce TRQ by 5 %

- NOTE ● : Add 0.5 % of TRQ for each additional 10 KIAS on climb airspeed.

Table not valid if **INERT SEP ON** and/or BLEED HI msg ON.

T° (°C)	Flight level (FL)											
	100	110	120	130	140	150	160	170	180	190	200	
-24	▲ CAUTION ▲ TRQ max 100 % Ng max 104 %											
-22	Recommended Ng < 103 %											
-20												
-18												
-16												
-14												
-12											100	
-10											100	
-8											98	
-6											100	
-4											99	
-2											98	
0											95	
2											93	
4											90	
6											87	
8											85	
10											82	
12											80	
14											77	
16											74	
18												
20												
22												
24												
26												
28												
30												
32												
34												

Figure 5.8.1 - Maximum climb power (FL < 200) - 124 KIAS

- NOTE ●

Refer to page 5.8.1 for general conditions

●

Pilot's Operating Handbook

Maximum climb power (FL > 200) - 124 KIAS

Conditions : If BLEED HI msg ON, reduce TRQ by 5 %

- NOTE • : Add 0.5 % of TRQ for each additional 10 KIAS on climb airspeed.

Table not valid if **INERT SEP ON** and/or BLEED HI msg ON.

T° (°C)	Flight level (FL)											
	200	210	220	230	240	250	260	270	280	290	300	310
-66									99	95	90	86
-64	▲ CAUTION ▲ TRQ max 100 % Ng max 104 % ▲			Recommended Ng < 103 %					98	94	89	85
-62									97	93	88	84
-60								100	96	92	87	83
-58								100	95	91	86	82
-56								99	94	90	85	81
-54								98	93	89	85	81
-52							100	97	92	88	84	80
-50							100	95	91	87	83	79
-48							99	94	90	86	82	78
-46							98	93	89	85	81	77
-44						100	97	92	88	84	80	77
-42						100	96	91	87	83	79	75
-40						99	95	90	86	82	78	74
-38						98	93	89	85	81	77	73
-36					100	97	92	88	84	80	76	72
-34					99	95	91	87	82	78	75	71
-32					98	94	90	85	81	77	73	70
-30				100	97	93	88	84	80	76	72	69
-28				100	96	92	87	83	79	75	71	68
-26				98	94	90	86	82	78	74	70	66
-24			100	97	93	89	85	80	76	73	69	65
-22			100	96	92	88	83	79	75	71	67	64
-20			99	95	90	86	82	78	74	70	66	62
-18		100	97	93	89	85	81	77	72	68	64	60
-16		100	96	92	88	83	79	75	71	66	62	59
-14		99	94	90	86	82	77	73	69	65	61	57
-12	100	97	93	89	85	80	75	71	67	63	59	55
-10	100	96	91	87	82	78	74	69	65	61	57	53
-8	98	94	89	85	81	76	72	67	63	59	55	51
-6	96	92	88	83	79	74	70	65	61	57	53	
-4	95	90	85	81	77	72	67	63	59	55		
-2	93	88	83	79	74	70	65	61	57			
0	91	85	81	76	71	67	63	59				
2	88	83	78	74	69	65	61					
4	85	80	76	71	67	63						
6	82	78	74	69	65							
8	80	76	71	67								
10	78	73	69									
12	75	70										

Figure 5.8.1A - Maximum climb power (FL > 200) - 124 KIAS

- NOTE •

Refer to page 5.8.1 for general conditions

•

Maximum climb power (FL < 200) - 170 KIAS / M 0.40

Conditions : If BLEED HI msg ON, reduce TRQ by 5 %

- NOTE ● : Add 0.5 % of TRQ for each additional 10 KIAS on climb airspeed.

Table not valid if **INERT SEP ON** and/or BLEED HI msg ON.

T° (°C)	Flight level (FL)											
	OAT	100	110	120	130	140	150	160	170	180	190	200
-24												
-22												
-20												
-18												
-16												
-14												
-12												
-10												
-8												100
-6												100
-4												98
-2												100
0												95
2												100
4												98
6												95
8												92
10												90
12												87
14												85
16												82
18												80
20												77
22												74
24												72
26												70
28												68
30												66
32												64
34												62

Figure 5.8.2 - Maximum climb power (FL < 200) - 170 KIAS / M 0.40

- NOTE ●

Refer to page 5.8.1 for general conditions

●

Pilot's Operating Handbook

Maximum climb power (FL > 200) - 170 KIAS / M 0.40

Conditions : If BLEED HI msg ON, reduce TRQ by 5 %

- NOTE • : Add 0.5 % of TRQ for each additional 10 KIAS on climb airspeed.

Table not valid if **INERT SEP ON** and/or BLEED HI msg ON.

T° (°C)	Flight level (FL)													
	200	210	220	230	240	250	260	270	280	290	300	310		
-66										98	93	88		
-64	▲ CAUTION ▲			Recommended Ng < 103 %								97	92	87
-62	TRQ max 100 %										100	96	91	86
-60	Ng max 104 %										100	95	90	85
-58	▲										99	94	89	84
-56									98	93	88	83		
-54								100	96	92	87	83		
-52								100	95	90	86	82		
-50								99	94	89	85	81		
-48								98	93	89	84	80		
-46							100	97	92	88	83	79		
-44							100	96	91	86	82	78		
-42							99	94	90	85	81	77		
-40							98	93	88	84	80	76		
-38						100	97	92	87	83	79	75		
-36						100	95	91	86	82	78	73		
-34						99	94	89	85	81	76	72		
-32						97	93	88	84	79	75	71		
-30					100	96	91	87	82	78	74	70		
-28					99	95	90	86	81	77	73	69		
-26					98	94	89	84	80	76	72	68		
-24					100	97	92	88	83	79	75	71		
-22					100	96	91	86	82	77	73	69		
-20					99	94	90	85	80	76	72	67		
-18			100	97	93	88	83	79	74	70	65	61		
-16			100	96	91	86	82	77	72	68	64	60		
-14			98	94	89	85	80	75	71	66	62	57		
-12		100	96	92	87	83	78	73	69	64	60	55		
-10		99	95	90	85	81	76	71	66	62	58	54		
-8	100	97	93	88	83	79	73	68	64	60	56	52		
-6	100	95	91	86	81	76	71	66	62	58	54			
-4	98	93	88	83	78	74	69	64	60	56				
-2	95	90	85	81	76	71	67	62	58					
0	92	88	83	78	74	69	65	60						
2	90	85	81	76	72	67	62							
4	87	83	78	74	69	65								
6	85	80	76	71	67									
8	82	78	73	69										
10	79	75	71											
12	77	72												

Figure 5.8.2A - Maximum climb power (FL > 200) - 170 KIAS / M 0.40

- NOTE •

Refer to page 5.8.1 for general conditions

•

Maximum cruise power (FL < 200)

Conditions : If BLEED HI msg ON, reduce TRQ by 5 %

- NOTE • : Use preferably recommended cruise power.

Table not valid if **INERT SEP ON** and/or BLEED HI msg ON.

T° (°C)	Flight level (FL)											
	100	110	120	130	140	150	160	170	180	190	200	
-24												
-22												
-20												
-18												
-16												
-14												
-12												
-10												
-8												
-6												
-4												
-2												
0												
2												100
4												98
6											100	95
8											98	92
10										100	95	89
12									100	97	92	87
14									99	94	89	84
16								100	97	91	86	
18								99	94	88		
20							100	96	91			
22							98	93				
24						100	95					
26				100	97							
28				99								
30			100									
32		100										
34	100											

Figure 5.8.3 - Maximum cruise power (FL < 200)

- NOTE •

Refer to page 5.8.1 for general conditions

•

Pilot's Operating Handbook

Maximum cruise power (FL > 200)

Conditions : If BLEED HI msg ON, reduce TRQ by 5 %

- NOTE • : Use preferably recommended cruise power.

Table not valid if **INERT SEP ON** and/or BLEED HI msg ON.

T° (°C)	Flight level (FL)														
	200	210	220	230	240	250	260	270	280	290	300	310			
-62												100			
-60	▲ CAUTION ▲ TRQ max 100 % Ng max 104 % ▲			Recommended Ng < 103 %									100		
-58														98	
-56														97	
-54														100	96
-52														99	94
-50											98	93			
-48										100	97	92			
-46										100	95	90			
-44										99	94	89			
-42										97	92	87			
-40									100	96	91	86			
-38									99	94	89	85			
-36									98	93	88	83			
-34								100	96	91	86	82			
-32								100	95	90	85	80			
-30								98	93	88	84	79			
-28								97	92	87	82	78			
-26								100	95	90	85	81	76		
-24								99	94	89	84	79	74		
-22								97	92	87	82	77	72		
-20							100	96	90	85	80	75	70		
-18							99	94	88	83	78	73	68		
-16						100	97	92	86	81	76	71	67		
-14					100	95	89	84	79	74	69	64	64		
-12					98	93	87	82	77	72	67	62	62		
-10				100	96	90	85	80	74	69	64	60	60		
-8				99	93	88	82	77	72	67	62	58	58		
-6			100	96	90	85	80	74	69	65	60				
-4			99	93	88	82	77	72	67	63					
-2		100	96	90	85	80	75	70	65						
0		98	93	87	82	77	73	68							
2	100	95	90	85	80	75	70								
4	98	93	88	82	77	73									
6	95	90	85	80	75										
8	92	87	82	77											
10	89	84	79												
12	87	81													

Figure 5.8.3A - Maximum cruise power (FL > 200)

- NOTE •

Refer to page 5.8.1 for general conditions

•

Normal (recommended) cruise power (FL < 200)

Conditions : If BLEED HI msg ON, reduce TRQ by 5 %

● NOTE ● : Table not valid if **INERT SEP ON** and/or BLEED HI msg ON.

T° (°C)	Flight level (FL)															
	100	110	120	130	140	150	160	170	180	190	200					
-24																
-22																
-20																
-18																
-16																
-14																
-12																
-10																
-8																
-6																
-4												100				
-2												99				
0											100	96				
2											99	94				
4											100	96	91			
6											99	93	88			
8											100	95	90	85		
10											100	98	92	87	82	
12											100	95	89	84	79	
14											100	97	92	86	81	77
16											99	94	89	84	79	
18											100	96	91	86	81	
20											100	98	93	88	83	
22											100	95	90	85		
24											100	97	92	87		
26											100	99	93	89		
28											100	95	90			
30											100	97	92			
32											99	94				
34											96					

Figure 5.8.4 - Normal (recommended) cruise power (FL < 200)

● NOTE ●
Refer to page 5.8.1 for general conditions

Pilot's Operating Handbook

Normal (recommended) cruise power (FL > 200)

Conditions : If BLEED HI msg ON, reduce TRQ by 5 %

• NOTE • : Table not valid if **INERT SEP ON** and/or BLEED HI msg ON.

T° (°C)	Flight level (FL)											
	200	210	220	230	240	250	260	270	280	290	300	310
-66												100
-64												99
-62												98
-60											100	96
-58											100	95
-56											98	93
-54										100	96	92
-52										100	95	90
-50										98	93	89
-48									100	97	92	87
-46									100	95	91	86
-44									99	94	89	84
-42									97	92	87	83
-40								100	96	91	86	82
-38								99	94	90	85	80
-36								98	93	88	83	79
-34							100	96	92	87	82	78
-32							100	95	90	85	81	76
-30							99	94	89	84	79	75
-28							97	92	87	82	78	73
-26							100	96	91	86	81	76
-24							99	94	89	84	79	74
-22						100	97	92	87	82	77	72
-20						100	95	90	85	80	75	70
-18						98	93	88	83	78	73	68
-16					100	96	91	86	81	76	71	66
-14					99	94	89	84	79	73	68	63
-12				100	97	92	87	81	76	71	66	61
-10				100	95	89	84	78	73	68	64	59
-8			100	97	92	86	81	76	71	66	62	57
-6			100	94	89	84	79	74	69	64	59	55
-4	100	97	91	86	81	76	71	66	62	57		
-2	99	94	89	83	79	74	69	64	59			
0	96	91	86	81	76	71	66	62				
2	94	88	83	78	73	69	64					
4	91	85	80	75	71	66						
6	88	83	78	73	68							
8	85	80	75	70								
10	82	77	72									
12	79	74										

Figure 5.8.4A - Normal (recommended) cruise power (FL > 200)

• NOTE •

Refer to page 5.8.1 for general conditions

•

Intentionally left blank

Pilot's Operating Handbook

5.9 - Takeoff distances

The following tables give the takeoff distances for several weight configurations.

All common information applicable to tables (pages 5.9.2 to 5.9.4) are listed below.

Associated conditions :

- Landing gear DN and flaps TO
- TRQ = 100 %
- BLEED switch on AUTO
- Hard, dry and level runway

In table headings :

- GR = Ground roll (in ft)
- D₅₀ = Takeoff distance (clear to 50 ft) (in ft)

● NOTE ●

Between ISA + 30°C and ISA + 37°C, it may be necessary to set the BLEED switch to OFF in order to get 100 % TRQ during takeoff within the engine ITT limitations. After takeoff, reduce power before setting the BLEED switch to AUTO.

In sea level ISA conditions, nominal Np is 1985 RPM.

●

Corrections :

- In case of wind, apply the following corrections :
 - Reduce total distances by 10 % every 10 kts of headwind
 - Increase total distances by 30 % every 10 kts of tail wind
- Other runway surfaces :

Takeoff distances given in the tables are for takeoff from a hard, dry and level runway. Other runway surfaces require the following correction factors.

Increase distances by :

- 7 % on hard grass
- 10 % on short grass
- 15 % on wet runway
- 25 % on high grass
- 30 % on slippery runway

Weight : 5512 lbs (2500 kg)

Associated condition :

- 15° of attitude after rotation
- Rotation speed choice (V_R)

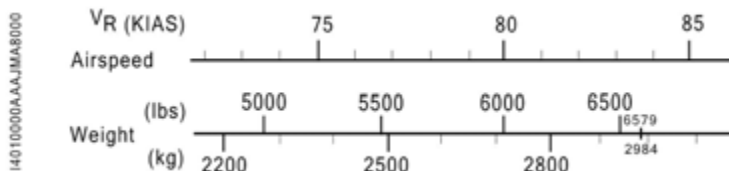

Weight : 5512 lbs (2500 kg) At 50 ft = 91 KIAS - 105 MPH IAS								
Pressure altitude ft	ISA - 35°C		ISA - 20°C		ISA - 10°C		ISA	
	GR	D50	GR	D50	GR	D50	GR	D50
0	665	1085	740	1190	780	1255	820	1295
2000	735	1185	800	1265	850	1340	905	1415
4000	800	1260	885	1380	935	1460	990	1545
6000	880	1375	965	1505	1025	1595	1090	1690
8000	965	1500	1060	1645	1140	1765	1220	1880
Pressure altitude ft	ISA + 10°C		ISA + 20°C		ISA + 30°C		ISA + 37°C	
	GR	D50	GR	D50	GR	D50	GR	D50
0	865	1365	920	1435	965	1505	1000	1555
2000	955	1490	1005	1565	1060	1645	1100	1705
4000	1050	1625	1110	1720	1180	1825	1230	1895
6000	1165	1800	1240	1910	1320	2020	1380	2100
8000	1305	2000	1390	2120	1480	2245	1565	2330

Figure 5.9.1 - Takeoff distances - 5512 lbs (2500 kg)

▲ CAUTION ▲

Refer to page 5.9.1 for notes and correction factors.

▲

Pilot's Operating Handbook

Weight : 6579 lbs (2984 kg)

Associated condition :

- 15° of attitude after rotation
- Rotation speed choice (V_R)

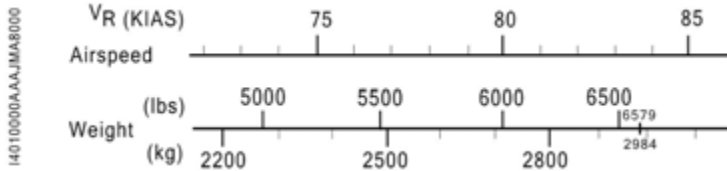

Weight : 6579 lbs (2984 kg) At 50 ft = 94 KIAS - 108 MPH IAS								
Pressure altitude ft	ISA - 35°C		ISA - 20°C		ISA - 10°C		ISA	
	GR	D50	GR	D50	GR	D50	GR	D50
0	1020	1470	1115	1600	1185	1680	1245	1765
2000	1115	1595	1220	1730	1285	1820	1355	1915
4000	1215	1725	1325	1875	1400	1975	1475	2075
6000	1320	1865	1445	2030	1545	2160	1645	2305
8000	1435	2020	1600	2240	1715	2400	1850	2570
Pressure altitude ft	ISA + 10°C		ISA + 20°C		ISA + 30°C		ISA + 37°C	
	GR	D50	GR	D50	GR	D50	GR	D50
0	1310	1855	1375	1940	1440	2030	1490	2090
2000	1425	2010	1500	2110	1595	2235	1660	2320
4000	1580	2205	1675	2345	1790	2485	1865	2590
6000	1755	2455	1880	2615	2005	2780	2095	2895
8000	1980	2745	2115	2925	2275	3110	2380	3245

Figure 5.9.2 - Takeoff distances - 6579 lbs (2984 kg)

▲ CAUTION ▲

Refer to page 5.9.1 for notes and correction factors.

▲

Weight : 7394 lbs (3354 kg)

Associated condition :

- 12.5° of attitude after rotation
- Rotation speed choice (V_R)

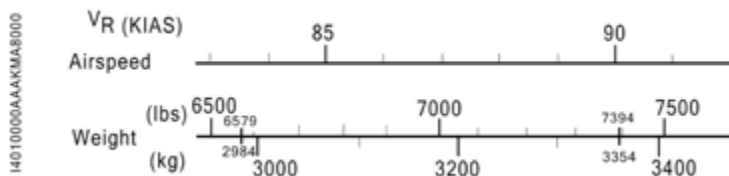

Weight : 7394 lbs (3354 kg) At 50 ft = 99 KIAS - 114 MPH IAS								
Pressure altitude ft	ISA - 35°C		ISA - 20°C		ISA - 10°C		ISA	
	GR	D50	GR	D50	GR	D50	GR	D50
0	1440	2020	1560	2175	1645	2275	1725	2380
2000	1555	2170	1690	2335	1770	2445	1860	2560
4000	1685	2325	1820	2505	1910	2630	2045	2785
6000	1810	2500	1970	2710	2130	2930	2290	3135
8000	1960	2695	2220	3045	2410	3265	2590	3490
Pressure altitude ft	ISA + 10°C		ISA + 20°C		ISA + 30°C		ISA + 37°C	
	GR	D50	GR	D50	GR	D50	GR	D50
0	1800	2485	1880	2595	1965	2705	2060	2810
2000	1945	2675	2080	2865	2215	3040	2325	3160
4000	2185	3000	2355	3200	2500	3385	2610	3520
6000	2470	3340	2640	3550	2810	3765	2935	3915
8000	2775	3720	2965	3950	3180	4185	3315	4350

Figure 5.9.3 - Takeoff distances - 7394 lbs (3354 kg)

▲ CAUTION ▲

Refer to page 5.9.1 for notes and correction factors.



5.10 - Climb performance

MXCL - Speeds (IAS = 124 KIAS)

Conditions :

- Maximum climb power TRQ = 100 %
- Landing gear and flaps UP
- IAS = 124 KIAS - BLEED switch on AUTO and BLEED HI msg OFF

Airplane weight	Pressure altitude (feet)	Rate of climb (ft/min)					
		ISA - 20°C	ISA - 10°C	ISA	ISA + 10°C	ISA + 20°C	ISA + 30°C
5794 lbs (2628 kg)	SL	2885	2870	2855	2845	2830	2810
	2000	2860	2845	2830	2810	2795	2775
	4000	2840	2820	2805	2785	2765	2750
	6000	2810	2790	2770	2750	2735	2710
	8000	2775	2755	2735	2710	2690	2665
6594 lbs (2991 kg)	SL	2440	2425	2410	2400	2380	2365
	2000	2415	2400	2385	2365	2350	2330
	4000	2395	2375	2360	2340	2325	2305
	6000	2365	2345	2330	2310	2290	2270
	8000	2335	2315	2290	2270	2250	2230
7394 lbs (3354 kg)	SL	2080	2065	2050	2040	2020	2005
	2000	2055	2040	2025	2005	1990	1975
	4000	2035	2015	1995	1980	1965	1945
	6000	2005	1985	1970	1950	1930	1910
	8000	1975	1955	1935	1910	1890	1870

Figure 5.10.1 - MXCL - Speeds (IAS = 124 KIAS)

● NOTE ●

In SL ISA conditions, nominal Np is of 1985 RPM.

●

MXCL - Speeds (IAS = 170 KIAS / M 0.40)

Conditions :

- Maximum climb power TRQ = 100 %
- Landing gear and flaps UP
- IAS = 170 KIAS / M 0.40
- BLEED switch on AUTO and BLEED HI msg OFF

Airplane weight	Pressure altitude (feet)	Rate of climb (ft/min)					
		ISA - 20°C	ISA - 10°C	ISA	ISA + 10°C	ISA + 20°C	ISA + 30°C
5794 lbs (2628 kg)	SL	2 420	2 390	2 365	2 335	2 310	2 285
	2000	2 385	2 355	2 325	2 295	2 265	2 235
	4000	2 345	2 315	2 280	2 250	2 220	2 190
	6000	2 305	2 270	2 235	2 205	2 170	2 140
	8000	2 260	2 225	2 190	2 155	2 120	2 085
6594 lbs (2991 kg)	SL	2 075	2 050	2 025	2 000	1 975	1 955
	2000	2 045	2 015	1 990	1 965	1 935	1 910
	4000	2 010	1 985	1 950	1 920	1 895	1 865
	6000	1 975	1 940	1 910	1 880	1 850	1 820
	8000	1 930	1 900	1 870	1 835	1 805	1 770
7394 lbs (3354 kg)	SL	1 800	1 775	1 755	1 730	1 710	1 685
	2000	1 770	1 745	1 720	1 695	1 670	1 645
	4000	1 735	1 710	1 685	1 655	1 630	1 605
	6000	1 705	1 670	1 645	1 615	1 590	1 560
	8000	1 660	1 635	1 605	1 575	1 545	1 515

Figure 5.10.2 - MXCL - Speeds (IAS = 170 KIAS / M 0.40)

• NOTE •

In SL ISA conditions, nominal Np is of 1985 RPM.

•

Pilot's Operating Handbook

MXCL - Time, consumption and climb distance (IAS = 124 KIAS)

Conditions :

- **ISA - 20°C**
- Maximum climb power
- Landing gear and flaps UP
- IAS = 124 KIAS - BLEED switch on AUTO

●NOTE ● : Time, consumption and distance from the 50 ft
If BLEED HI msg ON, reduce TRQ by 5 %. This TRQ reduction will result in :

- Time to climb increased by up to 7 %
- Climb distance increased by up to 7 %
- Fuel consumption increased by up to 5 %

Pressure altitude (ft)	Weight 5794 lbs (2628 kg)					Weight 6579 lbs (2984 kg)					Weight 7394 lbs (3354 kg)				
	Time (min. s)	Consump.			Dist. (NM)	Time (min. s)	Consump.			Dist. (NM)	Time (min. s)	Consump.			Dist. (NM)
		l	kg	USG			l	kg	USG			l	kg	USG	
SL	00:00	0	0	0	0	00:00	0	0	0	0	00:00	0	0	0	0
2000	00:45	4	3	1.0	1	00:45	5	4	1.2	2	01:00	5	4	1.4	2
4000	01:30	8	6	2.0	3	01:45	9	7	2.4	3	02:00	11	8	2.8	4
6000	02:15	11	9	3.0	4	02:30	13	10	3.5	5	03:00	16	12	4.1	6
8000	03:00	15	12	3.9	6	03:30	18	14	4.6	7	04:00	21	16	5.5	8
10000	03:30	18	14	4.9	8	04:15	22	17	5.7	9	05:00	26	20	6.8	11
12000	04:15	22	17	5.8	9	05:15	26	20	6.8	11	06:00	30	24	8.0	13
14000	05:00	25	20	6.7	11	06:00	30	23	7.9	13	07:15	35	28	9.3	16
16000	05:45	29	23	7.6	13	07:00	34	27	9.0	15	08:15	40	32	10.6	18
18000	06:30	32	25	8.5	15	07:45	38	30	10.0	18	09:15	45	35	11.9	21
20000	07:30	35	28	9.4	17	08:45	42	33	11.1	20	10:30	50	39	13.2	24
22000	08:15	39	30	10.3	19	09:45	46	36	12.2	23	11:30	55	43	14.4	27
24000	09:00	42	33	11.1	21	10:45	50	39	13.2	25	12:45	60	47	15.7	30
26000	09:45	46	36	12.0	24	11:45	54	43	14.3	28	13:45	64	51	17.0	34
28000	10:30	49	38	13.0	26	12:45	58	46	15.4	31	15:00	70	55	18.4	38
30000	11:30	53	41	13.9	29	13:45	63	49	16.6	35	16:30	75	59	19.8	42
31000	12:00	54	43	14.4	31	14:30	65	51	17.2	37	17:15	78	61	20.6	44

Figure 5.10.3 - MXCL - Time, consumption and climb distance (IAS = 124 KIAS) / ISA - 20°C

MXCL - Time, consumption and climb distance (IAS = 124 KIAS)

Conditions :

- **ISA**
- Maximum climb power
- Landing gear and flaps UP
- IAS = 124 KIAS - BLEED switch on AUTO

●NOTE ● : Time, consumption and distance from the 50 ft
If BLEED HI msg ON, reduce TRQ by 5%. This TRQ reduction will result in :

- Time to climb increased by up to 8 %
- Climb distance increased by up to 8 %
- Fuel consumption increased by up to 6 %

Pressure altitude (ft)	Weight 5794 lbs (2628 kg)					Weight 6579 lbs (2984 kg)					Weight 7394 lbs (3354 kg)				
	Time (min. s)	Consump.			Dist. (NM)	Time (min. s)	Consump.			Dist. (NM)	Time (min. s)	Consump.			Dist. (NM)
		l	kg	USG			l	kg	USG			l	kg	USG	
SL	00:00	0	0	0	0	00:00	0	0	0	0	00:00	0	0	0	0
2000	00:45	4	3	1.0	1	00:45	5	4	1.2	2	01:00	6	4	1.5	2
4000	01:30	8	6	2.1	3	01:45	9	7	2.4	4	02:00	11	9	2.9	4
6000	02:15	12	9	3.1	5	02:30	14	11	3.6	5	03:00	16	13	4.3	6
8000	03:00	15	12	4.1	6	03:30	18	14	4.8	7	04:00	21	17	5.7	9
10000	03:45	19	15	5.0	8	04:15	22	18	5.9	10	05:15	27	21	7.0	11
12000	04:30	23	18	6.0	10	05:15	27	21	7.1	12	06:15	32	25	8.4	14
14000	05:15	26	21	6.9	12	06:15	31	24	8.2	14	07:15	37	29	9.7	17
16000	06:00	30	23	7.9	14	07:00	35	28	9.3	16	08:15	42	33	11.0	19
18000	06:45	33	26	8.8	16	08:00	39	31	10.4	19	09:30	47	37	12.4	22
20000	07:30	37	29	9.7	18	09:00	44	34	11.5	21	10:45	52	41	13.7	26
22000	08:15	40	32	10.6	20	10:00	48	38	12.7	24	11:45	57	45	15.1	29
24000	09:15	44	34	11.6	23	11:00	52	41	13.8	27	13:00	62	49	16.5	32
26000	10:00	47	37	12.5	25	12:00	57	44	14.9	30	14:15	68	53	17.9	37
28000	11:00	51	40	13.5	28	13:15	61	48	16.2	34	16:00	73	58	19.4	41
30000	12:15	55	43	14.6	32	14:30	66	52	17.5	39	17:45	80	63	21.1	47
31000	12:45	57	45	15.1	34	15:30	69	54	18.2	41	18:45	83	65	21.9	51

Figure 5.10.4 - MXCL - Time, consumption and climb distance (IAS = 124 KIAS) / ISA

Pilot's Operating Handbook

MXCL - Time, consumption and climb distance (IAS = 124 KIAS)

Conditions :

- **ISA + 20°C**
- Maximum climb power
- Landing gear and flaps UP
- IAS = 124 KIAS - BLEED switch on AUTO

●NOTE ● : Time, consumption and distance from the 50 ft
If BLEED HI msg ON, reduce TRQ by 5%. This TRQ reduction will result in :

- Time to climb increased by up to 10 %
- Climb distance increased by up to 10 %
- Fuel consumption increased by up to 7 %

Pressure altitude (ft)	Weight 5794 lbs (2628 kg)					Weight 6579 lbs (2984 kg)					Weight 7394 lbs (3354 kg)				
	Time (min. s)	Consump.			Dist. (NM)	Time (min. s)	Consump.			Dist. (NM)	Time (min. s)	Consump.			Dist. (NM)
		l	kg	USG			l	kg	USG			l	kg	USG	
SL	00:00	0	0	0	0	00:00	0	0	0	0	00:00	0	0	0	0
2 000	00:45	4	3	1.1	2	00:45	5	4	1.3	2	01:00	6	4	1.5	2
4 000	01:30	8	6	2.1	3	01:45	10	8	2.5	4	02:00	11	9	3.0	4
6 000	02:15	12	9	3.2	5	02:30	14	11	3.8	6	03:00	17	13	4.5	7
8 000	03:00	16	12	4.2	7	03:30	19	15	5.0	8	04:15	22	17	5.9	9
10 000	03:45	20	15	5.2	8	04:30	23	18	6.2	10	05:15	28	22	7.3	12
12 000	04:30	23	18	6.2	10	05:15	28	22	7.3	12	06:15	33	26	8.7	15
14 000	05:15	27	21	7.2	12	06:15	32	25	8.5	15	07:30	38	30	10.1	18
16 000	06:00	31	24	8.1	14	07:15	37	29	9.7	17	08:30	44	34	11.5	21
18 000	06:45	34	27	9.1	17	08:15	41	32	10.8	20	09:45	49	38	12.9	24
20 000	07:45	38	30	10.1	19	09:15	46	36	12.0	23	11:00	54	43	14.4	27
22 000	08:30	42	33	11.1	22	10:15	50	39	13.2	26	12:15	60	47	15.9	31
24 000	09:45	46	36	12.1	25	11:30	55	43	14.5	30	14:00	66	52	17.5	36
26 000	10:45	50	39	13.2	28	13:00	60	47	15.9	34	15:45	73	57	19.2	42
28 000	12:00	54	43	14.4	33	14:30	66	51	17.3	40	17:45	80	63	21.0	49
30 000	13:30	59	46	15.6	38	16:30	72	56	18.9	46	20:15	88	69	23.2	58
31 000	14:15	62	48	16.3	41	17:30	75	59	19.8	50	21:45	92	72	24.4	63

Figure 5.10.5 - MXCL - Time, consumption and climb distance (IAS = 124 KIAS) / ISA + 20°C

MXCL - Time, consumption and climb distance (IAS = 170 KIAS / M 0.40)

Conditions :

- ISA - 20°C
- Maximum climb power
- Landing gear and flaps UP
- IAS = 170 KIAS / M 0.40 - BLEED switch on AUTO

●NOTE ● : Time, consumption and distance from the 50 ft
If BLEED HI msg ON, reduce TRQ by 5%. This TRQ reduction will result in :

- Time to climb increased by up to 10 %
- Climb distance increased by up to 10 %
- Fuel consumption increased by up to 7 %

Pressure altitude (ft)	Weight 5794 lbs (2628 kg)					Weight 6579 lbs (2984 kg)					Weight 7394 lbs (3354 kg)				
	Time (min. s)	Consump.			Dist. (NM)	Time (min. s)	Consump.			Dist. (NM)	Time (min. s)	Consump.			Dist. (NM)
		l	kg	USG			l	kg	USG			l	kg	USG	
SL	00:00	0	0	0	0	00:00	0	0	0	0	00:00	0	0	0	0
2000	00:45	4	3	1.2	2	01:00	5	4	1.4	3	01:00	6	5	1.6	3
4000	01:45	9	7	2.3	5	02:00	10	8	2.7	5	02:15	12	9	3.1	6
6000	02:30	13	10	3.5	7	03:00	15	12	4.0	8	03:30	18	14	4.7	10
8000	03:30	17	14	4.6	10	04:00	20	16	5.4	11	04:30	23	18	6.2	13
10000	04:15	22	17	5.7	12	05:00	25	20	6.7	15	05:45	29	23	7.7	17
12000	05:15	26	20	6.8	15	06:00	30	24	7.9	18	07:00	35	27	9.2	21
14000	06:00	30	24	7.9	18	07:00	35	27	9.3	22	08:15	41	32	10.8	25
16000	07:00	34	27	9.1	22	08:15	40	31	10.6	25	09:30	47	37	12.3	29
18000	08:00	39	30	10.2	25	09:15	45	35	11.9	29	11:00	52	41	13.8	34
20000	09:00	43	34	11.3	29	10:30	50	39	13.2	33	12:15	58	46	15.4	39
22000	10:00	47	37	12.4	32	11:45	55	43	14.6	38	13:45	64	50	17.0	44
24000	11:00	51	40	13.6	36	13:00	60	47	15.9	43	15:00	70	55	18.6	50
26000	12:00	55	43	14.6	40	14:00	65	51	17.0	47	16:30	76	59	20.0	55
28000	12:45	59	46	15.5	43	15:00	69	54	18.2	51	17:30	81	63	21.3	59
30000	13:45	62	49	16.5	46	16:00	73	57	19.3	55	19:00	86	67	22.7	64
31000	14:15	64	50	16.9	48	16:45	75	59	19.9	57	19:45	89	70	23.4	67

Figure 5.10.6 - MXCL - Time, consumption and climb distance
(IAS = 170 KIAS / M 0.40) / ISA - 20°C

Pilot's Operating Handbook

**MXCL - Time, consumption and climb distance
(IAS = 170 KIAS / M 0.40)**

Conditions :

- **ISA**
- Maximum climb power
- Landing gear and flaps UP
- IAS = 170 KIAS / M 0.40 - BLEED switch on AUTO

●NOTE ● : Time, consumption and distance from the 50 ft
If BLEED HI msg ON, reduce TRQ by 5%. This TRQ reduction will result in :

- Time to climb increased by up to 11 %
- Climb distance increased by up to 11 %
- Fuel consumption increased by up to 8 %

Pressure altitude (ft)	Weight 5794 lbs (2628 kg)					Weight 6579 lbs (2984 kg)					Weight 7394 lbs (3354 kg)				
	Time (min. s)	Consump.			Dist. (NM)	Time (min. s)	Consump.			Dist. (NM)	Time (min. s)	Consump.			Dist. (NM)
		l	kg	USG			l	kg	USG			l	kg	USG	
SL	00:00	0	0	0	0	00:00	0	0	0	0	00:00	0	0	0	0
2000	00:45	5	4	1.2	2	01:00	5	4	1.4	3	01:15	6	5	1.7	3
4000	01:45	9	7	2.4	5	02:00	11	8	2.8	6	02:15	12	10	3.3	7
6000	02:30	14	11	3.6	8	03:00	16	13	4.2	9	03:30	19	15	4.9	10
8000	03:30	18	14	4.8	10	04:00	21	17	5.6	12	04:45	25	19	6.5	14
10000	04:30	23	18	6.0	13	05:15	26	21	7.0	16	06:00	31	24	8.1	18
12000	05:15	27	21	7.2	16	06:15	32	25	8.4	19	07:15	37	29	9.7	22
14000	06:15	32	25	8.4	20	07:15	37	29	9.8	23	08:30	43	34	11.4	27
16000	07:15	36	28	9.5	23	08:30	42	33	11.2	27	10:00	49	39	13.0	32
18000	08:15	41	32	10.7	27	09:45	48	37	12.6	32	11:15	56	44	14.7	37
20000	09:15	45	36	11.9	31	11:00	53	42	14.0	36	12:45	62	49	16.4	42
22000	10:30	50	39	13.2	35	12:15	58	46	15.4	41	14:15	68	54	18.1	48
24000	11:30	54	43	14.4	39	13:30	64	50	16.9	46	15:45	75	59	19.8	54
26000	12:30	59	46	15.5	43	14:45	69	54	18.2	51	17:15	81	63	21.3	60
28000	13:30	63	49	16.5	48	16:00	74	58	19.5	56	18:45	87	68	22.9	66
30000	14:45	67	52	17.6	52	17:15	79	62	20.8	62	20:30	93	73	24.6	73
31000	15:15	69	54	18.2	55	18:15	81	64	21.5	65	21:30	96	76	25.5	77

Figure 5.10.7 - MXCL - Time, consumption and climb distance
(IAS = 170 KIAS / M 0.40) / ISA

MXCL - Time, consumption and climb distance (IAS = 170 KIAS / M 0.40)

Conditions :

- ISA + 20°C
- Maximum climb power
- Landing gear and flaps UP
- IAS = 170 KIAS / M 0.40 - BLEED switch on AUTO

●NOTE ● : Time, consumption and distance from the 50 ft

If BLEED HI msg ON, reduce TRQ by 5 %. This TRQ reduction will result in :

- Time to climb increased by up to 15 %
- Climb distance increased by up to 16 %
- Fuel consumption increased by up to 12 %

Pressure altitude (ft)	Weight 5794 lbs (2628 kg)					Weight 6579 lbs (2984 kg)					Weight 7394 lbs (3354 kg)				
	Time (min. s)	Consump.			Dist. (NM)	Time (min. s)	Consump.			Dist. (NM)	Time (min. s)	Consump.			Dist. (NM)
		l	kg	USG			l	kg	USG			l	kg	USG	
SL	00:00	0	0	0	0	00:00	0	0	0	0	00:00	0	0	0	0
2000	00:45	5	4	1.3	3	01:00	6	4	1.5	3	01:15	7	5	1.7	3
4000	01:45	10	8	2.6	5	02:00	11	9	3.0	6	02:30	13	10	3.5	7
6000	02:45	14	11	3.8	8	03:00	17	13	4.5	9	03:30	20	15	5.2	11
8000	03:30	19	15	5.1	11	04:15	22	18	5.9	13	05:00	26	20	6.9	15
10000	04:30	24	19	6.3	14	05:15	28	22	7.4	17	06:15	33	26	8.6	19
12000	05:30	29	22	7.5	18	06:30	33	26	8.8	21	07:30	39	31	10.3	24
14000	06:30	33	26	8.8	21	07:30	39	31	10.3	25	09:00	46	36	12.0	29
16000	07:30	38	30	10.1	25	08:45	45	35	11.8	29	10:15	52	41	13.8	34
18000	08:30	43	34	11.3	29	10:00	50	40	13.3	34	11:45	59	46	15.6	40
20000	09:45	48	38	12.7	33	11:30	56	44	14.8	39	13:15	66	52	17.4	46
22000	11:00	53	42	14.1	38	13:00	63	49	16.5	45	15:15	74	58	19.5	53
24000	12:30	59	46	15.6	45	14:45	70	55	18.4	53	17:15	82	64	21.7	62
26000	13:45	64	50	17.0	51	16:30	76	60	20.1	60	19:30	90	71	23.8	72
28000	15:30	70	55	18.4	57	18:15	83	65	21.9	68	22:00	99	77	26.1	82
30000	17:15	75	59	19.8	64	20:30	90	70	23.7	77	25:00	108	85	28.5	94
31000	18:00	78	61	20.6	68	21:45	93	73	24.7	82	26:30	113	89	29.8	101

Figure 5.10.8 - MXCL - Time, consumption and climb distance
(IAS = 170 KIAS / M 0.40) / ISA + 20°C

Pilot's Operating Handbook

Climb performance after go-around

Conditions :

- Landing gear DN and flaps LDG
- **IAS = 90 KIAS**

Airplane weight	Pressure altitude (feet)	Rate of climb (ft/min)						
		ISA - 35°C	ISA - 20°C	ISA - 10°C	ISA	ISA + 10°C	ISA + 20°C	ISA + 30°C
6594 lbs (2991 kg)	SL	1635	1610	1590	1565	1545	1525	1505
	2000	1615	1580	1555	1535	1510	1490	1470
	4000	1585	1545	1525	1500	1480	1455	1435
	6000	1555	1515	1490	1465	1440	1420	1395
	8000	1520	1480	1455	1430	1400	1375	1345

Conditions :

- Landing gear DN and flaps LDG
- **IAS = 95 KIAS**

Airplane weight	Pressure altitude (feet)	Rate of climb (ft/min)						
		ISA - 35°C	ISA - 20°C	ISA - 10°C	ISA	ISA + 10°C	ISA + 20°C	ISA + 30°C
7394 lbs (3354 kg)	SL	1350	1320	1295	1275	1255	1235	1215
	2000	1325	1290	1265	1245	1225	1205	1180
	4000	1295	1255	1235	1210	1190	1165	1140
	6000	1265	1225	1200	1175	1150	1120	1095
	8000	1230	1190	1160	1135	1105	1075	1050

Figure 5.10.9 - Climb performance after go-around

Climb performance - Flaps TO

Conditions :

- Landing gear UP and flaps TO
- **IAS = 110 KIAS**

Airplane weight	Pressure altitude (feet)	Rate of climb (ft/min)						
		ISA - 35°C	ISA - 20°C	ISA - 10°C	ISA	ISA + 10°C	ISA + 20°C	ISA + 30°C
6594 lbs (2991 kg)	SL	2295	2275	2260	2250	2240	2225	2215
	2000	2280	2260	2245	2230	2220	2210	2190
	4000	2265	2245	2230	2215	2200	2180	2165
	6000	2250	2225	2210	2190	2175	2155	2135
	8000	2235	2205	2185	2165	2145	2130	2110

Conditions:

- Landing gear UP and flaps TO
- **IAS = 115 KIAS**

Airplane weight	Pressure altitude (feet)	Rate of climb (ft/min)						
		ISA - 35°C	ISA - 20°C	ISA - 10°C	ISA	ISA + 10°C	ISA + 20°C	ISA + 30°C
7394 lbs (3354 kg)	SL	1985	1965	1955	1940	1930	1915	1900
	2000	1970	1950	1940	1925	1910	1890	1875
	4000	1955	1935	1920	1900	1885	1865	1850
	6000	1940	1910	1895	1875	1860	1840	1825
	8000	1915	1890	1870	1850	1835	1815	1795

Figure 5.10.10 - Climb performance - Flaps TO

5.11 - Cruise performance

Maximum cruise

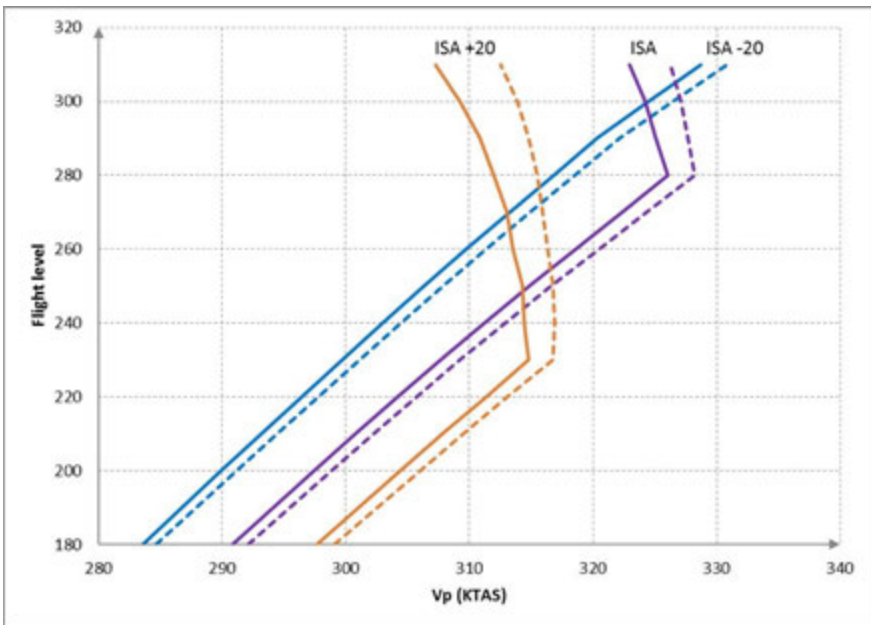

————— 7100 lbs
- - - - - 6300 lbs

Figure 5.11.1 - Cruise performance (Maximum cruise)

Maximum cruise

Conditions :

- **ISA - 20°C**
- Landing gear and flaps UP
- BLEED switch on AUTO and BLEED HI msg OFF

- NOTE • : Use preferably recommended cruise power.
If BLEED HI msg ON, reduce TRQ by 5 %. This TRQ reduction will result in an airspeed reduction of up to 5 KIAS.

Pressure altitude (feet)	OAT (°C)	TRQ (%)	Fuel flow			Airspeeds (kt)					
						5500 lbs (2495 kg)		6300 lbs (2858 kg)		7100 lbs (3220 kg)	
			l / h	kg / h	USG / h	IAS	TAS	IAS	TAS	IAS	TAS
SL	-4	100	325	255	85.9	240	236	239	236	239	235
5000	-14	100	299	234	78.9	235	248	235	248	234	247
10000	-24	100	278	218	73.3	230	262	230	261	229	260
15000	-34	100	265	208	70.1	226	276	225	275	224	275
18000	-40	100	256	201	67.7	223	285	222	285	221	284
20000	-44	100	251	197	66.2	221	292	220	291	219	290
21000	-46	100	248	195	65.6	220	295	219	294	218	293
22000	-48	100	246	193	65.0	219	299	218	298	217	296
23000	-50	100	244	192	64.5	218	302	217	301	216	300
24000	-52	100	243	190	64.1	217	306	216	304	215	303
25000	-54	100	241	189	63.7	216	309	215	308	214	306
26000	-56	100	240	188	63.3	215	313	214	311	213	310
27000	-57	100	239	188	63.2	214	316	213	315	212	313
28000	-59	100	238	187	63.0	213	320	212	318	211	317
29000	-61	100	238	187	62.9	212	324	211	322	209	320
30000	-63	100	238	187	62.8	211	328	210	326	209	324
31000	-65	100	238	187	63.0	210	332	209	331	208	329

Figure 5.11.2 - Cruise performance
Maximum cruise / ISA - 20°C

Maximum cruise

Conditions :

- **ISA - 10°C**
- Landing gear and flaps UP
- BLEED switch on AUTO and BLEED HI msg OFF

• NOTE • : Use preferably recommended cruise power.

If BLEED HI msg ON, reduce TRQ by 5 %. This TRQ reduction will result in an airspeed reduction of up to 6 KIAS.

Pressure altitude (feet)	OAT (°C)	TRQ (%)	Fuel flow			Airspeeds (kt)					
						5500 lbs (2495 kg)		6300 lbs (2858 kg)		7100 lbs (3220 kg)	
			l / h	kg / h	USG / h	IAS	TAS	IAS	TAS	IAS	TAS
SL	6	100	329	258	86.9	238	239	238	239	237	238
5000	-4	100	302	237	79.7	234	252	233	251	233	250
10000	-14	100	281	220	74.2	229	265	228	265	228	264
15000	-24	100	268	210	70.8	224	280	223	279	222	278
18000	-30	100	259	203	68.4	221	289	220	288	219	287
20000	-34	100	253	199	66.9	219	296	218	295	217	294
21000	-36	100	251	197	66.2	218	299	217	298	216	297
22000	-38	100	249	195	65.7	217	303	216	302	215	300
23000	-40	100	247	194	65.1	216	306	215	305	214	304
24000	-42	100	245	192	64.7	215	310	214	309	213	307
25000	-44	100	243	191	64.3	214	314	213	312	212	311
26000	-46	100	242	190	63.9	213	317	212	316	211	314
27000	-47	100	242	190	63.8	212	321	211	320	210	318
28000	-49	100	241	189	63.6	211	325	210	323	209	322
29000	-51	100	240	189	63.5	210	329	209	328	208	326
30000	-53	100	239	188	63.2	209	333	208	332	207	329
31000	-55	97	230	181	60.8	205	333	204	331	202	328

Figure 5.11.3 - Cruise performance
Maximum cruise / ISA - 10°C

Maximum cruise

Conditions :

- **ISA - 5°C**
- Landing gear and flaps UP
- BLEED switch on AUTO and BLEED HI msg OFF

- NOTE ● : Use preferably recommended cruise power.
If BLEED HI msg ON, reduce TRQ by 5 %. This TRQ reduction will result in an airspeed reduction of up to 6 KIAS.

Pressure altitude (feet)	OAT (°C)	TRQ (%)	Fuel flow			Airspeeds (kt)					
						5500 lbs (2495 kg)		6300 lbs (2858 kg)		7100 lbs (3220 kg)	
			l / h	kg / h	USG / h	IAS	TAS	IAS	TAS	IAS	TAS
SL	11	100	331	259	87.3	238	240	237	240	237	240
5000	1	100	304	238	80.2	233	253	232	253	232	252
10000	-9	100	282	221	74.5	228	267	227	266	227	265
15000	-19	100	269	211	71.2	223	282	222	281	222	280
18000	-25	100	260	204	68.7	220	291	219	290	218	289
20000	-29	100	254	200	67.2	218	298	217	297	216	296
21000	-31	100	252	198	66.5	217	301	216	300	215	299
22000	-33	100	250	196	66.0	216	305	215	304	214	302
23000	-35	100	248	195	65.5	215	308	214	307	213	306
24000	-37	100	246	193	65.0	214	312	213	311	212	309
25000	-39	100	244	192	64.6	213	316	212	315	211	313
26000	-41	100	243	191	64.2	212	320	211	318	210	316
27000	-42	100	243	191	64.1	211	323	210	322	209	320
28000	-44	100	242	190	64.0	210	328	209	326	208	324
29000	-46	100	242	190	63.8	210	332	209	330	207	328
30000	-48	97	233	183	61.5	206	332	205	330	203	327
31000	-50	94	224	176	59.3	202	332	200	329	199	326

Figure 5.11.4 - Cruise performance
Maximum cruise / ISA - 5°C

Maximum cruise

Conditions :

- **ISA**
- Landing gear and flaps UP
- BLEED switch on AUTO and BLEED HI msg OFF

• NOTE • : Use preferably recommended cruise power.

If BLEED HI msg ON, reduce TRQ by 5 %. This TRQ reduction will result in an airspeed reduction of up to 6 KIAS.

Pressure altitude (feet)	OAT (°C)	TRQ (%)	Fuel flow			Airspeeds (kt)					
						5500 lbs (2495 kg)		6300 lbs (2858 kg)		7100 lbs (3220 kg)	
			l / h	kg / h	USG / h	IAS	TAS	IAS	TAS	IAS	TAS
SL	16	100	333	261	87.9	237	242	237	242	236	241
5000	6	100	305	240	80.7	232	255	232	254	231	253
10000	-4	100	284	223	74.9	227	268	227	268	226	267
15000	-14	100	271	213	71.5	222	283	222	283	221	282
18000	-20	100	261	205	69.0	219	293	219	292	218	291
20000	-24	100	256	201	67.6	217	300	216	299	215	297
21000	-26	100	253	199	66.9	216	303	215	302	214	301
22000	-28	100	251	197	66.3	215	307	214	306	213	304
23000	-30	100	249	195	65.8	214	310	213	309	212	308
24000	-32	100	247	194	65.3	213	314	212	313	211	311
25000	-34	100	246	193	64.9	212	318	211	317	210	315
26000	-36	100	244	192	64.5	211	322	210	320	209	319
27000	-37	100	244	191	64.4	210	326	209	324	208	322
28000	-39	100	242	190	64.1	210	330	208	328	207	326
29000	-41	97	234	184	61.8	206	330	204	328	203	325
30000	-43	94	226	177	59.7	202	329	200	327	199	324
31000	-45	90	218	171	57.5	198	329	196	326	194	323

Figure 5.11.5 - Cruise performance
Maximum cruise / ISA

Maximum cruise

Conditions :

- **ISA + 5°C**
- Landing gear and flaps UP
- BLEED switch on AUTO and BLEED HI msg OFF

- NOTE ● : Use preferably recommended cruise power.
If BLEED HI msg ON, reduce TRQ by 5 %. This TRQ reduction will result in an airspeed reduction of up to 5 KIAS.

Pressure altitude (feet)	OAT (°C)	TRQ (%)	Fuel flow			Airspeeds (kt)					
						5500 lbs (2495 kg)		6300 lbs (2858 kg)		7100 lbs (3220 kg)	
			l / h	kg / h	USG / h	IAS	TAS	IAS	TAS	IAS	TAS
SL	21	100	334	263	88.4	236	243	236	243	235	242
5000	11	100	307	241	81.1	231	256	231	256	230	255
10000	1	100	285	224	75.3	226	270	226	269	225	269
15000	-9	100	272	214	72.0	221	285	221	284	220	283
18000	-15	100	263	206	69.4	218	295	218	294	217	293
20000	-19	100	257	202	67.9	216	302	216	301	215	299
21000	-21	100	254	200	67.2	215	305	215	304	213	303
22000	-23	100	252	198	66.6	214	309	214	308	212	306
23000	-25	100	250	196	66.1	213	312	213	311	211	309
24000	-27	100	248	195	65.7	212	316	212	315	210	313
25000	-29	100	247	194	65.2	211	320	210	319	209	317
26000	-31	100	245	192	64.8	210	324	209	322	208	320
27000	-32	100	244	192	64.6	210	328	209	326	207	324
28000	-34	97	236	185	62.3	206	328	204	326	203	323
29000	-36	93	227	178	60.0	202	327	200	325	199	322
30000	-38	90	219	172	57.9	198	327	196	324	194	321
31000	-40	87	211	166	55.8	194	326	192	323	190	320

Figure 5.11.6 - Cruise performance
Maximum cruise / ISA + 5°C

Maximum cruise

Conditions :

- **ISA + 10°C**
- Landing gear and flaps UP
- BLEED switch on AUTO and BLEED HI msg OFF

- NOTE ● : Use preferably recommended cruise power.
If BLEED HI msg ON, reduce TRQ by 5 %. This TRQ reduction will result in an airspeed reduction of up to 5 KIAS.

Pressure altitude (feet)	OAT (°C)	TRQ (%)	Fuel flow			Airspeeds (kt)					
						5500 lbs (2495 kg)		6300 lbs (2858 kg)		7100 lbs (3220 kg)	
			l / h	kg / h	USG / h	IAS	TAS	IAS	TAS	IAS	TAS
SL	26	100	336	264	88.9	236	245	235	244	235	244
5000	16	100	309	242	81.6	231	258	230	257	230	256
10000	6	100	287	225	75.7	226	272	225	271	224	270
15000	-4	100	274	215	72.3	221	287	220	286	219	285
18000	-10	100	264	207	69.7	218	297	217	296	216	294
20000	-14	100	258	203	68.3	216	303	215	302	214	301
21000	-16	100	256	201	67.6	215	307	214	306	213	304
22000	-18	100	254	199	67.0	214	311	213	309	211	308
23000	-20	100	252	197	66.5	212	314	212	313	210	311
24000	-22	100	250	196	66.0	212	318	211	317	209	315
25000	-24	100	248	195	65.5	211	322	210	320	208	319
26000	-26	100	246	193	65.1	210	326	209	325	207	323
27000	-27	97	238	187	62.8	206	325	204	324	203	321
28000	-29	93	229	180	60.5	202	325	200	323	198	320
29000	-31	90	221	173	58.3	198	325	196	322	194	319
30000	-33	86	213	167	56.2	194	324	192	321	190	317
31000	-35	83	205	161	54.1	190	323	188	320	186	316

Figure 5.11.7 - Cruise performance
Maximum cruise / ISA + 10°C

Maximum cruise

Conditions :

- **ISA + 20°C**
- Landing gear and flaps UP
- BLEED switch on AUTO and BLEED HI msg OFF

- NOTE • : Use preferably recommended cruise power.
If BLEED HI msg ON, reduce TRQ by 5 %. This TRQ reduction will result in an airspeed reduction of up to 6 KIAS.

Pressure altitude (feet)	OAT (°C)	TRQ (%)	Fuel flow			Airspeeds (kt)					
						5500 lbs (2495 kg)		6300 lbs (2858 kg)		7100 lbs (3220 kg)	
			l / h	kg / h	USG / h	IAS	TAS	IAS	TAS	IAS	TAS
SL	36	100	340	267	89.8	234	247	234	247	233	246
5000	26	100	312	245	82.5	229	261	229	260	228	259
10000	16	100	290	227	76.5	224	275	224	274	223	273
15000	6	100	276	217	73.0	219	290	218	289	217	288
18000	0	100	266	209	70.4	216	300	215	299	214	298
20000	-4	100	261	205	69.0	214	307	213	306	212	304
21000	-6	100	258	203	68.3	213	311	212	309	211	308
22000	-8	100	256	201	67.6	212	314	211	313	210	311
23000	-10	100	254	200	67.1	211	318	210	317	209	315
24000	-12	98	246	193	65.0	208	319	206	317	205	314
25000	-14	95	238	187	62.8	204	319	203	317	201	314
26000	-16	92	230	180	60.7	200	318	199	316	197	314
27000	-17	88	222	174	58.6	197	318	195	316	193	313
28000	-19	85	214	168	56.6	193	318	192	316	189	312
29000	-21	82	207	162	54.6	190	318	188	315	185	311
30000	-23	79	199	156	52.7	186	317	184	314	181	309
31000	-25	76	192	151	50.7	182	316	180	313	177	307

Figure 5.11.8 - Cruise performance
Maximum cruise / ISA + 20°C

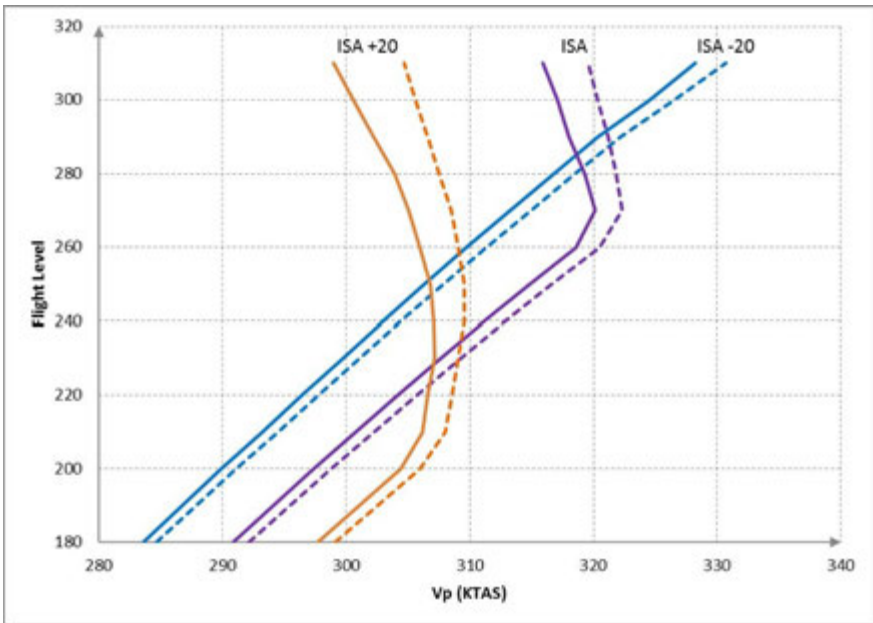
Normal cruise (Recommended)

— 7100 lbs
- - 6300 lbs

Figure 5.11.9 - Cruise performance (Recommended cruise)

Normal cruise (Recommended)

Conditions :

- **ISA - 20°C**
- Landing gear and flaps UP
- BLEED switch on AUTO and BLEED HI msg OFF

- **NOTE** • : Power recommended by PRATT & WHITNEY CANADA
If BLEED HI msg ON, reduce TRQ by 5 %. This TRQ reduction will result in an airspeed reduction of up to 6 KIAS.

Pressure altitude (feet)	OAT (°C)	TRQ (%)	Fuel flow			Airspeeds (kt)					
						5500 lbs (2495 kg)		6300 lbs (2858 kg)		7100 lbs (3220 kg)	
			l / h	kg / h	USG / h	IAS	TAS	IAS	TAS	IAS	TAS
SL	-4	100	325	255	85.9	240	236	239	236	239	235
5000	-14	100	299	234	78.9	235	248	235	248	234	247
10000	-24	100	278	218	73.3	230	262	230	261	229	260
15000	-34	100	265	208	70.1	226	276	225	275	224	275
18000	-40	100	256	201	67.7	223	285	222	285	221	284
20000	-44	100	251	197	66.2	221	292	220	291	219	290
21000	-46	100	248	195	65.6	220	295	219	294	218	293
22000	-48	100	246	193	65.0	219	299	218	298	217	296
23000	-50	100	244	192	64.5	218	302	217	301	216	300
24000	-52	100	243	190	64.1	217	306	216	304	215	303
25000	-54	100	241	189	63.7	216	309	215	308	214	306
26000	-56	100	240	188	63.3	215	313	214	311	213	310
27000	-57	100	239	188	63.2	214	316	213	315	212	313
28000	-59	100	238	187	63.0	213	320	212	318	211	317
29000	-61	100	238	187	62.9	212	324	211	322	209	320
30000	-63	100	238	187	62.8	211	328	210	326	209	324
31000	-65	100	238	187	62.9	210	332	209	331	208	328

Figure 5.11.10 - Cruise performance
Normal cruise / ISA - 20°C

Normal cruise (Recommended)

Conditions :

- **ISA - 10°C**
- Landing gear and flaps UP
- BLEED switch on AUTO and BLEED HI msg OFF

- **NOTE** • : Power recommended by PRATT & WHITNEY CANADA
If BLEED HI msg ON, reduce TRQ by 5 %. This TRQ reduction will result in an airspeed reduction of up to 5 KIAS.

Pressure altitude (feet)	OAT (°C)	TRQ (%)	Fuel flow			Airspeeds (kt)					
						5500 lbs (2495 kg)		6300 lbs (2858 kg)		7100 lbs (3220 kg)	
			l / h	kg / h	USG / h	IAS	TAS	IAS	TAS	IAS	TAS
SL	6	100	329	258	86.9	238	239	238	239	237	238
5000	-4	100	302	237	79.7	234	252	233	251	233	250
10000	-14	100	281	220	74.2	229	265	228	265	228	264
15000	-24	100	268	210	70.8	224	280	223	279	222	278
18000	-30	100	259	203	68.4	221	289	220	288	219	287
20000	-34	100	253	199	66.9	219	296	218	295	217	294
21000	-36	100	251	197	66.2	218	299	217	298	216	297
22000	-38	100	249	195	65.7	217	303	216	302	215	300
23000	-40	100	247	194	65.1	216	306	215	305	214	304
24000	-42	100	245	192	64.7	215	310	214	309	213	307
25000	-44	100	243	191	64.3	214	314	213	312	212	311
26000	-46	100	242	190	63.9	213	317	212	316	211	314
27000	-47	100	242	190	63.8	212	321	211	320	210	318
28000	-49	100	241	189	63.6	211	325	210	323	209	322
29000	-51	100	238	187	62.9	210	328	209	327	207	324
30000	-53	96	230	180	60.7	206	328	204	326	203	323
31000	-55	93	222	174	58.6	202	328	200	325	198	322

Figure 5.11.11 - Cruise performance
Normal cruise / ISA - 10°C

Normal cruise (Recommended)

Conditions :

- ISA - 5°C
- Landing gear and flaps UP
- BLEED switch on AUTO and BLEED HI msg OFF

- NOTE ● : Power recommended by PRATT & WHITNEY CANADA
If BLEED HI msg ON, reduce TRQ by 5 %. This TRQ reduction will result in an airspeed reduction of up to 5 KIAS.

Pressure altitude (feet)	OAT (°C)	TRQ (%)	Fuel flow			Airspeeds (kt)					
						5500 lbs (2495 kg)		6300 lbs (2858 kg)		7100 lbs (3220 kg)	
			l / h	kg / h	USG / h	IAS	TAS	IAS	TAS	IAS	TAS
SL	11	100	331	259	87.3	238	240	237	240	237	240
5000	1	100	304	238	80.2	233	253	232	253	232	252
10000	-9	100	282	221	74.5	228	267	227	266	227	265
15000	-19	100	269	211	71.2	223	282	222	281	222	280
18000	-25	100	260	204	68.7	220	291	219	290	218	289
20000	-29	100	254	200	67.2	218	298	217	297	216	296
21000	-31	100	252	198	66.5	217	301	216	300	215	299
22000	-33	100	250	196	66.0	216	305	215	304	214	302
23000	-35	100	248	195	65.5	215	308	214	307	213	306
24000	-37	100	246	193	65.0	214	312	213	311	212	309
25000	-39	100	244	192	64.6	213	316	212	315	211	313
26000	-41	100	243	191	64.2	212	320	211	318	210	316
27000	-42	100	243	191	64.1	211	323	210	322	209	320
28000	-44	100	239	188	63.2	210	326	208	324	207	322
29000	-46	96	231	181	61.0	206	326	204	324	202	321
30000	-48	93	223	175	58.9	202	325	200	323	198	320
31000	-50	89	215	169	56.8	198	325	196	322	194	319

Figure 5.11.12 - Cruise performance
Normal cruise / ISA - 5°C

Normal cruise (Recommended)

Conditions :

- **ISA**
- Landing gear and flaps UP
- BLEED switch on AUTO and BLEED HI msg OFF

- **NOTE** ● : Power recommended by PRATT & WHITNEY CANADA
If BLEED HI msg ON, reduce TRQ by 5 %. This TRQ reduction will result in an airspeed reduction of up to 5 KIAS.

Pressure altitude (feet)	OAT (°C)	TRQ (%)	Fuel flow			Airspeeds (kt)					
						5500 lbs (2495 kg)		6300 lbs (2858 kg)		7100 lbs (3220 kg)	
			l / h	kg / h	USG / h	IAS	TAS	IAS	TAS	IAS	TAS
SL	16	100	333	261	87.9	237	242	237	242	236	241
5000	6	100	305	240	80.7	232	255	232	254	231	253
10000	-4	100	284	223	74.9	227	268	227	268	226	267
15000	-14	100	271	213	71.5	222	283	222	283	221	282
18000	-20	100	261	205	69.0	219	293	219	292	218	291
20000	-24	100	256	201	67.6	217	300	216	299	215	297
21000	-26	100	253	199	66.9	216	303	215	302	214	301
22000	-28	100	251	197	66.3	215	307	214	306	213	304
23000	-30	100	249	195	65.8	214	310	213	309	212	308
24000	-32	100	247	194	65.3	213	314	212	313	211	311
25000	-34	100	246	193	64.9	212	318	211	317	210	315
26000	-36	100	244	192	64.5	211	322	210	320	209	319
27000	-37	99	241	189	63.6	209	324	208	322	207	320
28000	-39	96	232	182	61.4	205	324	204	322	202	319
29000	-41	92	224	176	59.2	201	323	200	321	198	318
30000	-43	89	216	170	57.0	198	323	196	320	194	317
31000	-45	86	208	164	55.0	194	322	192	320	190	316

Figure 5.11.13 - Cruise performance
Normal cruise / ISA

Normal cruise (Recommended)

Conditions :

- **ISA + 5°C**
- Landing gear and flaps UP
- BLEED switch on AUTO and BLEED HI msg OFF

- NOTE ● : Power recommended by PRATT & WHITNEY CANADA
If BLEED HI msg ON, reduce TRQ by 5 %. This TRQ reduction will result in an airspeed reduction of up to 5 KIAS.

Pressure altitude (feet)	OAT (°C)	TRQ (%)	Fuel flow			Airspeeds (kt)					
						5500 lbs (2495 kg)		6300 lbs (2858 kg)		7100 lbs (3220 kg)	
			l / h	kg / h	USG / h	IAS	TAS	IAS	TAS	IAS	TAS
SL	21	100	334	263	88.4	236	243	236	243	235	242
5000	11	100	307	241	81.1	231	256	231	256	230	255
10000	1	100	285	224	75.3	226	270	226	269	225	269
15000	-9	100	272	214	72.0	221	285	221	284	220	283
18000	-15	100	263	206	69.4	218	295	218	294	217	293
20000	-19	100	257	202	67.9	216	302	216	301	215	299
21000	-21	100	254	200	67.2	215	305	215	304	213	303
22000	-23	100	252	198	66.6	214	309	214	308	212	306
23000	-25	100	250	196	66.1	213	312	213	311	211	309
24000	-27	100	248	195	65.7	212	316	212	315	210	313
25000	-29	100	247	194	65.2	211	320	210	319	209	317
26000	-31	99	242	190	64.0	209	322	208	320	207	318
27000	-32	96	234	184	61.8	205	322	204	320	202	317
28000	-34	92	226	177	59.6	202	321	200	319	198	316
29000	-36	89	217	171	57.4	198	321	196	319	194	315
30000	-38	85	209	164	55.3	194	320	192	318	190	314
31000	-40	82	202	158	53.3	190	320	188	317	186	313

Figure 5.11.14 - Cruise performance
Normal cruise / ISA + 5°C

Normal cruise (Recommended)

Conditions :

- **ISA + 10°C**
- Landing gear and flaps UP
- BLEED switch on AUTO and BLEED HI msg OFF

- NOTE ● : Power recommended by PRATT & WHITNEY CANADA
If BLEED HI msg ON, reduce TRQ by 5 %. This TRQ reduction will result in an airspeed reduction of up to 6 KIAS.

Pressure altitude (feet)	OAT (°C)	TRQ (%)	Fuel flow			Airspeeds (kt)					
						5500 lbs (2495 kg)		6300 lbs (2858 kg)		7100 lbs (3220 kg)	
			l / h	kg / h	USG / h	IAS	TAS	IAS	TAS	IAS	TAS
SL	26	100	336	264	88.9	236	245	235	244	235	244
5000	16	100	309	242	81.6	231	258	230	257	230	256
10000	6	100	287	225	75.7	226	272	225	271	224	270
15000	-4	100	274	215	72.3	221	287	220	286	219	285
18000	-10	100	264	207	69.7	218	297	217	296	216	294
20000	-14	100	258	203	68.3	216	303	215	302	214	301
21000	-16	100	256	201	67.6	215	307	214	306	213	304
22000	-18	100	254	199	67.0	214	311	213	309	211	308
23000	-20	100	252	197	66.5	212	314	212	313	210	311
24000	-22	100	250	196	66.0	212	318	211	317	209	315
25000	-24	99	244	192	64.6	209	320	208	318	207	316
26000	-26	96	236	185	62.3	205	320	204	318	203	316
27000	-27	92	227	178	60.1	202	319	200	317	198	315
28000	-29	89	219	172	57.9	198	319	196	317	194	313
29000	-31	85	211	166	55.8	194	318	192	316	190	312
30000	-33	82	203	160	53.7	190	318	188	315	186	311
31000	-35	79	196	154	51.7	186	317	184	313	182	309

Figure 5.11.15 - Cruise performance
Normal cruise / ISA + 10°C

Normal cruise (Recommended)

Conditions :

- **ISA + 20°C**
- Landing gear and flaps UP
- BLEED switch on AUTO and BLEED HI msg OFF

● NOTE ● : Power recommended by PRATT & WHITNEY CANADA

If BLEED HI msg ON, reduce TRQ by 5 %. This TRQ reduction will result in an airspeed reduction of up to 6 KIAS.

Pressure altitude (feet)	OAT (°C)	TRQ (%)	Fuel flow			Airspeeds (kt)					
						5500 lbs (2495 kg)		6300 lbs (2858 kg)		7100 lbs (3220 kg)	
			l / h	kg / h	USG / h	IAS	TAS	IAS	TAS	IAS	TAS
SL	36	100	340	267	89.8	234	247	234	247	233	246
5000	26	100	312	245	82.5	229	261	229	260	228	259
10000	16	100	290	227	76.5	224	275	224	274	223	273
15000	6	100	276	217	73.0	219	290	218	289	217	288
18000	0	100	266	209	70.4	216	300	215	299	214	298
20000	-4	100	261	205	69.0	214	307	213	306	212	304
21000	-6	100	256	201	67.6	212	309	211	308	210	306
22000	-8	97	248	195	65.6	209	310	208	309	206	307
23000	-10	95	241	189	63.7	206	311	205	309	203	307
24000	-12	92	234	184	61.8	203	311	201	310	200	307
25000	-14	89	226	178	59.8	199	312	198	310	196	307
26000	-16	86	219	172	57.7	196	311	194	309	192	306
27000	-17	83	211	166	55.7	192	311	190	308	188	305
28000	-19	80	203	160	53.7	188	310	187	308	184	304
29000	-21	77	196	154	51.8	185	310	183	307	180	302
30000	-23	74	189	148	50.0	181	309	179	306	176	301
31000	-25	72	183	143	48.2	178	309	175	305	172	299

Figure 5.11.16 - Cruise performance
Normal cruise / ISA + 20°C

Pilot's Operating Handbook

Long range cruise (5500 lbs - 2495 kg)

Conditions :

- Landing gear and flaps UP
- BLEED switch on AUTO and BLEED HI msg OFF

Legend :

OAT : °C IAS : KIAS
 FF : USG/h
 FF : kg/h TAS : KTAS

Pressure altitude (feet)	TRQ (%)	ISA - 20°C		ISA - 10°C		ISA		ISA + 10°C		ISA + 20°C	
15000	38	-34	153	-24	152	-14	150	-4	148	6	147
		40.7		41.2		41.4		41.6		42.2	
		121	189	122	192	123	193	124	194	125	197
18000	39	-40	150	-30	149	-20	148	-10	147	0	146
		38.2		38.7		39.2		39.7		40.2	
		113	194	115	197	116	200	118	203	119	205
19000	39	-42	149	-32	148	-22	147	-12	145	-2	143
		37.4		37.9		38.4		38.7		38.9	
		111	196	113	199	114	202	115	203	116	204
20000	39	-44	150	-34	148	-24	147	-14	146	-4	144
		37.0		37.3		37.9		38.4		38.7	
		110	201	111	202	112	205	114	208	115	209
21000	39	-46	148	-36	147	-26	146	-16	145	-6	144
		36.0		36.6		37.1		37.6		38.2	
		107	201	109	204	110	207	112	210	113	213
22000	39	-48	147	-38	146	-28	145	-18	143	-8	142
		35.3		35.8		36.4		36.6		37.2	
		105	203	106	206	108	209	109	211	111	214
23000	39	-50	146	-40	145	-30	144	-20	142	-10	141
		34.5		35.1		35.6		35.9		36.4	
		103	205	104	209	106	212	107	213	108	216
24000	40	-52	146	-42	145	-32	144	-22	142	-12	141
		34.1		34.6		35.2		35.4		36.0	
		101	209	103	212	104	215	105	217	107	219

Figure 5.11.17 (1/2) - Cruise performance
 Long range cruise (5500 lbs - 2495 kg) (Altitude < 24000 ft)

Long range cruise (5500 lbs - 2495 kg)

Conditions :

- Landing gear and flaps UP
- BLEED switch on AUTO and BLEED HI msg OFF

Legend :

OAT : °C IAS : KIAS
 FF : USG/h
 FF : kg/h TAS : KTAS

Pressure altitude (feet)	TRQ (%)	ISA - 20°C		ISA - 10°C		ISA		ISA + 10°C		ISA + 20°C	
24 000	40	-52	146	-42	145	-32	144	-22	142	-12	141
		34.1		34.6		35.2		35.4		36.0	
		101	209	103	212	104	215	105	217	107	219
25 000	41	-54	148	-44	146	-34	145	-24	144	-14	142
		34.1		34.4		34.9		35.5		35.8	
		101	215	102	217	104	220	105	223	106	225
26 000	43	-56	151	-46	150	-36	148	-26	146	-16	145
		34.6		35.1		35.4		35.6		36.2	
		103	223	104	226	105	228	106	230	108	233
27 000	45	-57	152	-47	151	-37	150	-27	148	-17	147
		34.6		35.1		35.7		36.0		36.5	
		103	228	104	232	106	235	107	237	108	241
28 000	46	-59	153	-49	152	-39	151	-29	149	-19	147
		34.5		35.1		35.7		36.0		36.3	
		103	233	104	237	106	241	107	243	108	245
29 000	46	-61	153	-51	151	-41	150	-31	148	-21	146
		34.3		34.6		35.2		35.5		35.7	
		102	237	103	240	104	244	105	246	106	248
30 000	46	-63	153	-53	151	-43	149	-33	148	-23	146
		34.2		34.4		34.7		35.3		35.6	
		101	241	102	244	103	246	105	250	106	252
31 000	46	-65	152	-55	150	-45	148	-35	147	-25	145
		33.7		34.0		34.3		34.8		35.1	
		100	244	101	247	102	249	103	253	104	255

Figure 5.11.17 (2/2) - Cruise performance
 Long range cruise (5500 lbs - 2495 kg) (Altitude > 24000 ft)

Pilot's Operating Handbook

Long range cruise (6300 lbs - 2858 kg)

Conditions :

- Landing gear and flaps UP
- BLEED switch on AUTO and BLEED HI msg OFF

Legend :

OAT : °C IAS : KIAS
 FF : USG/h
 FF : kg/h TAS : KTAS

Pressure altitude (feet)	TRQ (%)	ISA - 20°C		ISA - 10°C		ISA		ISA + 10°C		ISA + 20°C	
15 000	42	-34	156	-24	155	-14	154	-4	153	6	152
		42.3		42.9		43.5		44.0		44.6	
		126	193	128	195	129	198	131	201	133	203
18 000	42	-40	154	-30	152	-20	151	-10	150	0	149
		40.0		40.4		41.0		41.6		42.1	
		119	199	120	201	122	204	124	207	125	209
19 000	43	-42	156	-32	154	-22	152	-12	151	-2	150
		40.0		40.3		40.7		41.3		41.9	
		119	205	120	207	121	209	123	211	124	214
20 000	43	-44	154	-34	153	-24	151	-14	150	-4	149
		38.9		39.5		39.9		40.5		41.1	
		116	206	117	209	118	211	120	214	122	216
21 000	44	-46	153	-36	152	-26	151	-16	150	-6	149
		38.2		38.7		39.4		39.9		40.6	
		113	208	115	211	117	214	119	217	121	220
22 000	44	-48	152	-38	151	-28	150	-18	149	-8	148
		37.4		38.0		38.6		39.2		39.8	
		111	210	113	213	115	216	117	219	118	222
23 000	44	-50	152	-40	151	-30	149	-20	148	-10	147
		36.9		37.5		37.9		38.5		39.1	
		110	213	111	217	113	219	114	222	116	225
24 000	44	-52	150	-42	149	-32	148	-22	147	-12	146
		36.0		36.6		37.2		37.8		38.4	
		107	214	109	218	111	221	112	224	114	227

Figure 5.11.18 (1/2) - Cruise performance
 Long range cruise (6300 lbs - 2858 kg) (Altitude < 24000 ft)

Long range cruise (6300 lbs - 2858 kg)

Conditions :

- Landing gear and flaps UP
- BLEED switch on AUTO and BLEED HI msg OFF

Legend :

OAT : °C IAS : KIAS
 FF : USG/h
 FF : kg/h TAS : KTAS

Pressure altitude (feet)	TRQ (%)	ISA - 20°C		ISA - 10°C		ISA		ISA + 10°C		ISA + 20°C	
24 000	44	-52	150	-42	149	-32	148	-22	147	-12	146
		36.0		36.6		37.2		37.8		38.4	
		107	214	109	218	111	221	112	224	114	227
25 000	44	-54	149	-44	148	-34	147	-24	145	-14	143
		35.4		36.0		36.6		36.9		37.2	
		105	216	107	220	109	223	110	225	111	226
26 000	45	-56	152	-46	150	-36	148	-26	147	-16	146
		35.9		36.2		36.6		37.2		37.8	
		107	224	108	226	109	228	111	232	112	235
27 000	47	-57	154	-47	152	-37	150	-27	148	-17	147
		36.2		36.5		36.9		37.2		37.8	
		107	231	108	233	109	235	111	237	112	241
28 000	49	-59	156	-49	154	-39	152	-29	151	-19	149
		36.5		36.8		37.2		37.8		38.2	
		108	238	109	240	111	243	112	246	113	248
29 000	49	-61	155	-51	153	-41	151	-31	149	-21	147
		36.1		36.4		36.8		37.1		37.4	
		107	240	108	243	109	245	110	247	111	249
30 000	50	-63	155	-53	153	-43	151	-33	149	-23	147
		35.9		36.2		36.6		37.0		37.3	
		107	244	108	247	109	250	110	252	111	254
31 000	50	-65	154	-55	152	-45	150	-35	148	-25	146
		35.5		35.8		36.2		36.6		37.0	
		105	247	106	250	108	252	109	255	110	257

Figure 5.11.18 (2/2) - Cruise performance
 Long range cruise (6300 lbs - 2858 kg) (Altitude > 24000 ft)

Pilot's Operating Handbook

Long range cruise (7100 lbs - 3220 kg)

Conditions :

- Landing gear and flaps UP
- BLEED switch on AUTO and BLEED HI msg OFF

Legend :

OAT : °C IAS : KIAS
 FF : USG/h
 FF : kg/h TAS : KTAS

Pressure altitude (feet)	TRQ (%)	ISA - 20°C		ISA - 10°C		ISA		ISA + 10°C		ISA + 20°C	
15 000	48	-34	164	-24	163	-14	162	-4	161	6	160
		45.4		46.0		46.7		47.4		48.0	
		135	202	137	205	139	208	141	211	143	213
18 000	49	-40	161	-30	160	-20	159	-10	158	0	157
		42.7		43.5		43.9		44.8		45.5	
		127	208	129	211	130	214	133	217	135	220
19 000	49	-42	160	-32	159	-22	158	-12	157	-2	156
		42.0		42.6		43.3		44.0		44.6	
		125	210	127	213	129	217	131	219	133	222
20 000	49	-44	160	-34	159	-24	157	-14	156	-4	155
		41.4		42.1		42.5		43.2		43.9	
		123	214	125	217	126	219	128	222	130	225
21 000	49	-46	158	-36	157	-26	156	-16	155	-6	154
		40.4		41.1		41.8		42.4		43.1	
		120	214	122	218	124	221	126	224	128	227
22 000	49	-48	157	-38	156	-28	155	-18	153	-8	152
		39.8		40.4		41.0		41.4		42.1	
		118	217	120	220	122	223	123	225	125	228
23 000	49	-50	155	-40	154	-30	153	-20	150	-10	148
		38.9		39.5		40.1		40.3		40.7	
		116	217	117	221	119	224	120	225	121	226
24 000	49	-52	154	-42	153	-32	152	-22	150	-12	149
		38.3		38.9		39.6		40.0		40.6	
		114	220	116	223	118	227	119	228	121	231

Figure 5.11.19 (1/2) - Cruise performance
 Long range cruise (7100 lbs - 3220 kg) (Altitude < 24000 ft)

Long range cruise (7100 lbs - 3220 kg)

Conditions :

- Landing gear and flaps UP
- BLEED switch on AUTO and BLEED HI msg OFF

Legend :

OAT : °C IAS : KIAS
 FF : USG/h
 FF : kg/h TAS : KTAS

Pressure altitude (feet)	TRQ (%)	ISA - 20°C		ISA - 10°C		ISA		ISA + 10°C		ISA + 20°C	
24 000	49	-52	154	-42	153	-32	152	-22	150	-12	149
		38.3		38.9		39.6		40.0		40.6	
		114	220	116	223	118	227	119	228	121	231
25 000	49	-54	153	-44	152	-34	151	-24	149	-14	147
		37.7		38.3		39.0		39.4		39.8	
		112	222	114	226	116	229	117	231	118	232
26 000	51	-56	153	-46	151	-36	150	-26	149	-16	148
		37.4		37.9		38.5		39.2		39.8	
		111	226	113	228	114	231	117	235	118	238
27 000	52	-57	155	-47	153	-37	151	-27	149	-17	148
		37.7		38.1		38.5		39.0		39.6	
		112	232	113	235	114	237	116	239	118	242
28 000	53	-59	157	-49	154	-39	152	-29	150	-19	149
		38.1		38.2		38.7		39.1		39.8	
		113	239	114	240	115	243	116	245	118	248
29 000	53	-61	156	-51	154	-41	152	-31	150	-21	148
		37.7		38.1		38.6		39.0		39.5	
		112	242	113	244	115	247	116	249	117	251
30 000	53	-63	155	-53	153	-43	151	-33	149	-23	147
		37.3		37.8		38.2		38.7		39.1	
		111	244	112	247	113	250	115	252	116	254
31 000	49	-65	155	-55	153	-45	150	-35	148	-25	146
		37.3		37.7		37.9		38.3		38.8	
		111	249	112	251	113	252	114	255	115	257

Figure 5.11.19 (2/2) - Cruise performance
 Long range cruise (7100 lbs - 3220 kg) (Altitude > 24000 ft)

5.12 - Time, consumption and descent distance

Conditions :

- Power as required to maintain constant Vz
- Landing gear and flaps UP
- CAS = 230 KCAS - BLEED switch on AUTO

Pressure altitude (feet)	Vz = 1500 ft/min					Vz = 2000 ft/min					Vz = 2500 ft/min				
	Time (min. s)	Consump.			Dist. (NM)	Time (min. s)	Consump.			Dist. (NM)	Time (min. s)	Consump.			Dist. (NM)
		l	kg	us gal			l	kg	us gal			l	kg	us gal	
31000	20:40	70	55	18.5	101	15:30	47	37	12.4	75	12:25	34	27	9.0	60
30000	20:00	68	53	17.9	97	15:00	45	36	12.0	72	12:00	33	26	8.8	58
28000	18:40	64	50	16.8	89	14:00	43	34	11.3	66	11:10	31	25	8.3	53
26000	17:20	59	47	15.7	81	13:00	40	31	10.6	61	10:25	29	23	7.8	48
24000	16:00	55	43	14.5	73	12:00	37	29	9.8	55	09:35	28	22	7.3	44
22000	14:40	51	40	13.4	66	11:00	34	27	9.1	50	08:50	26	20	6.8	40
20000	13:20	47	37	12.3	59	10:00	32	25	8.4	44	08:00	24	19	6.3	35
18000	12:00	42	33	11.1	53	09:00	29	23	7.6	39	07:10	22	17	5.8	31
16000	10:40	38	30	10.0	46	08:00	26	20	6.8	34	06:25	20	15	5.2	27
14000	09:20	33	26	8.8	40	07:00	23	18	6.1	30	05:35	18	14	4.6	24
12000	08:00	29	23	7.6	33	06:00	20	16	5.3	25	04:50	15	12	4.1	20
10000	06:40	24	19	6.4	27	05:00	17	13	4.5	21	04:00	13	10	3.4	16
8000	05:20	20	15	5.2	22	04:00	14	11	3.7	16	03:10	11	8	2.8	13
6000	04:00	15	12	3.9	16	03:00	11	8	2.8	12	02:25	8	6	2.2	10
4000	02:40	10	8	2.7	10	02:00	7	6	1.9	8	01:35	6	4	1.5	6
2000	01:20	5	4	1.4	5	01:00	4	3	1.0	4	00:50	3	2	0.8	3
SL	00:00	0	0	0	0	00:00	0	0	0	0	00:00	0	0	0	0

Figure 5.12.1 - Time, consumption and descent distance

Intentionally left blank

5.13 - Holding time

Conditions :

- Landing gear and flaps UP
- IAS = 120 KIAS - BLEED switch on AUTO
- TRQ ≈ 26 %

Pressure altitude (feet)	Fuel used during holding time											
	Weight 5500 lbs (2495 kg)						Weight 6300 lbs (2858 kg)					
	10 min			30 min			10 min			30 min		
	l	kg	USG	l	kg	USG	l	kg	USG	l	kg	USG
SL	30	23	7.8	89	70	23.5	30	24	8.0	91	71	24.1
5000	26	21	6.9	79	62	20.8	27	21	7.1	81	64	21.4
10000	24	18	6.2	71	55	18.7	24	19	6.5	73	58	19.4
15000	22	17	5.8	66	51	17.3	23	18	6.0	69	54	18.1
20000	20	16	5.3	60	47	15.9	21	17	5.6	63	50	16.7

Figure 5.13.1 - Holding time

Intentionally left blank

5.14 - Landing distances

The following tables give the landing distances for several weight configurations.

All common information applicable to tables (pages 5.14.2 to 5.14.4) are listed below.

Associated conditions :

- Landing gear DN and flaps LDG
- Maximum braking without reverse
- Hard, dry and level runway

In table headings :

- GR = Ground roll (in ft)
- D₅₀ = Landing distance (clear to 50 ft) (in ft)

Corrections :

- In case of wind, apply the following corrections :
 - Reduce total distances by 10 % every 10 kts of headwind
 - Increase total distances by 30 % every 10 kts of tail wind
- Other runway surfaces :

Landing distances given in the tables are for landing on hard, dry and level runway. Other runway surfaces require the following correction factors.

Increase distances by :

- 7 % on hard grass
- 10 % on short grass
- 15 % on wet runway
- 25 % on high grass
- 30 % on slippery runway

Weight : 7024 lbs (3186 kg)

Associated conditions :

- Approach speed IAS = 85 KIAS
- Touch-down speed IAS = 78 KIAS

Pressure altitude ft	ISA - 35°C		ISA - 20°C		ISA - 10°C		ISA	
	GR	D50	GR	D50	GR	D50	GR	D50
0	1575	2135	1675	2265	1740	2330	1840	2430
2000	1675	2265	1805	2395	1870	2495	1970	2590
4000	1805	2395	1940	2560	2035	2660	2135	2790
6000	1940	2560	2100	2725	2200	2855	2300	2955
8000	2100	2725	2265	2920	2360	3020	2495	3180
Pressure altitude ft	ISA + 10°C		ISA + 20°C		ISA + 30°C		ISA + 37°C	
	GR	D50	GR	D50	GR	D50	GR	D50
0	1905	2530	2000	2625	2070	2690	2135	2790
2000	2070	2690	2135	2790	2230	2890	2300	2955
4000	2230	2890	2330	2985	2430	3085	2495	3185
6000	2395	3050	2530	3215	2625	3315	2690	3380
8000	2590	3280	2725	3410	2855	3570	2920	3640

Figure 5.14.1 - Landing distances - 7024 lbs (3186 kg)

▲ **CAUTION** ▲

Refer to page 5.14.1 for correction factors.



Weight : 6250 lbs (2835 kg)

Associated conditions :

- Approach speed IAS = 80 KIAS
- Touch-down speed IAS = 65 KIAS

Pressure altitude ft	ISA - 35°C		ISA - 20°C		ISA - 10°C		ISA	
	GR	D50	GR	D50	GR	D50	GR	D50
0	1050	1900	1115	2000	1180	2070	1215	2135
2000	1115	2000	1215	2100	1245	2200	1310	2265
4000	1180	2100	1280	2230	1345	2330	1410	2395
6000	1280	2230	1380	2360	1445	2460	1510	2525
8000	1380	2360	1475	2490	1540	2590	1610	2690
Pressure altitude ft	ISA + 10°C		ISA + 20°C		ISA + 30°C		ISA + 37°C	
	GR	D50	GR	D50	GR	D50	GR	D50
0	1280	2200	1310	2300	1380	2360	1445	2430
2000	1345	2330	1410	2430	1475	2495	1540	2560
4000	1445	2460	1510	2560	1575	2655	1640	2755
6000	1575	2645	1640	2720	1705	2820	1770	2920
8000	1705	2790	1770	2885	1835	2985	1900	3085

Figure 5.14.2 - Landing distances - 6250 lbs (2835 kg)

▲ CAUTION ▲

Refer to page 5.14.1 for correction factors.



Weight : 5071 lbs (2300 kg)

Associated conditions :

- Approach speed IAS = 80 KIAS
- Touch-down speed IAS = 60 KIAS

Pressure altitude ft	ISA - 35°C		ISA - 20°C		ISA - 10°C		ISA	
	GR	D50	GR	D50	GR	D50	GR	D50
0	885	1900	950	2000	1000	2070	1030	2135
2000	950	2000	1030	2100	1065	2200	1115	2265
4000	1000	2100	1080	2230	1150	2330	1200	2395
6000	1080	2230	1180	2360	1230	2460	1280	2525
8000	1180	2360	1245	2490	1310	2590	1360	2690
Pressure altitude ft	ISA + 10°C		ISA + 20°C		ISA + 30°C		ISA + 37°C	
	GR	D50	GR	D50	GR	D50	GR	D50
0	1080	2200	1115	2300	1180	2360	1230	2430
2000	1150	2330	1200	2430	1245	2495	1310	2560
4000	1230	2460	1280	2560	1345	2655	1395	2755
6000	1345	2645	1395	2720	1445	2820	1510	2920
8000	1445	2790	1510	2885	1560	2985	1610	3085

Figure 5.14.3 - Landing distances - 5071 lbs (2300 kg)

▲ **CAUTION** ▲

Refer to page 5.14.1 for correction factors.



Section 6**Weight and balance**

Table of contents

6.1	-	General	6.1.1
6.2	-	Airplane weighing procedures	6.2.1
6.3	-	Baggage loading	6.3.1
6.4	-	Determining weight and balance	6.4.1
		General	6.4.1
		Utilization of weight and balance graph	6.4.1
		Airplane loading form (m, kg)	6.4.4
		Example of airplane weight and balance report	6.4.8
		Weight and balance form and diagram (m, kg)	6.4.10
		Weight and balance form and diagram (in, lbs)	6.4.14
		Weight and balance samples (m, kg)	6.4.19
		Weight and balance samples (in, lbs)	6.4.23
		Determining empty airplane characteristics	6.4.26
6.5	-	List of equipment	6.5.1

Intentionally left blank

6.1 - General

This section is intended to provide the pilot with the procedure to determine the weight and balance of the airplane.

▲ WARNING ▲

It is the pilot's responsibility to ensure that the airplane is properly loaded and the weight and balance limits are adhered to.



This airplane allows multiple cabin seat configurations between 2 seats and 6 seats, as required by the operator - refer to chapter 7.3.

A list of equipment available for this airplane is referenced at the end of this POH - refer to chapter 6.5.

The list of specific optional equipment installed on your airplane as delivered from the factory can be found in the records carried in the airplane.

Intentionally left blank

6.2 - Airplane weighing procedures

Refer to maintenance manual for the procedures to use.

• NOTE •

Weighing carried out at the factory takes into account all equipment installed on the airplane. The list of this equipment and the total weight is noted in the individual inspection record.

•

Intentionally left blank

6.3 - Baggage loading

There are two baggage compartments :

- one in fuselage non pressurized forward section, between firewall and cockpit with maximum baggage capacity of 110 lbs (50 kg),
- one located in the rear of the pressurized cabin with following characteristics :

>> *With 6-seat configuration*

- in the baggage compartment, behind the rear seats, with maximum loading capacity of 220 lbs (100 kg).
- stowing straps are provided for securing parcels and baggage on compartment floor. A partition net separating the cabin from the baggage compartment is attached to frame C14.

>> *With other allowed seat accommodations*

There are two loading areas :

- one in place of the 2 removed rear seats, with maximum loading capacity of 176 lbs (80 kg),
- one, in the baggage compartment, behind the rear seats area, with maximum loading capacity of 220 lbs (100 kg).

Two types of baggage securing nets can be used :

- the small cargo net is attached through nine anchoring points on seat rails, between frame C11 and frame C13bis - refer to section 2 for limitations, Figure 7.2.1B.
- the large cargo net is attached through seven anchoring points on seat rails, between frame C11 and frame C13bis and six anchoring points on fuselage sides, at frame C14 - refer to section 2 for limitations, Figure 7.2.1A.

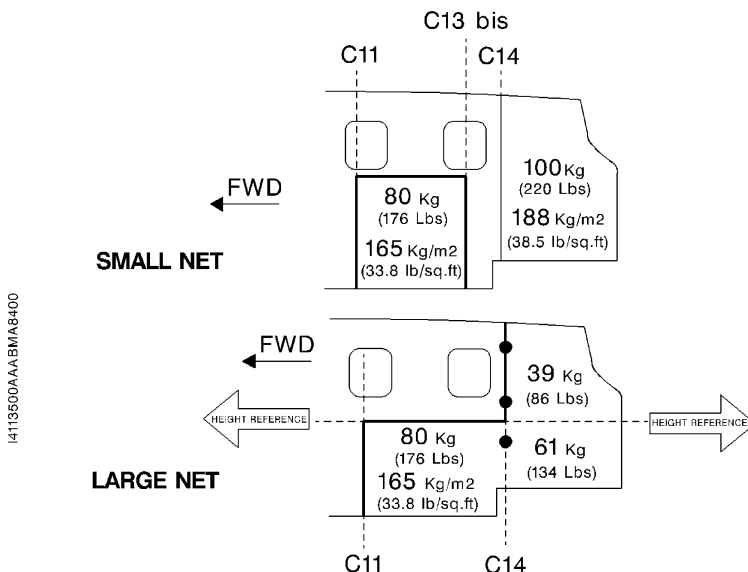

Figure 6.3.1 - Baggage limits

Authorized anchoring points are identified with green self-adhesive labels affixed to the inside of the rail.

A placard indicates loading limits for each securing net.

Evenly distribute the load within the cargo zone and ensure that overall weight is centered.

When using the large net, distribute the weight in each zone, delineated by the step in the floor, according to the zone limits.

>> All

▲ WARNING ▲

It is the pilot's responsibility to check that all parcels and baggages are properly secured in the cabin.

Transport of dangerous product is normally prohibited, however if transport of such product is necessary, it must be performed in compliance with regulations concerning transport of dangerous product and any other applicable regulation.



Baggage compartments loading must be done in accordance with the weight and balance limits of the airplane - refer to section 2 for limitations.

Generally, if rear seats are not used or are removed, first load AFT compartment, then, if required, FWD compartment. If rear seats are used, first load FWD compartment, then, if required, AFT compartment.

Compute and check the weight and balance diagram to ensure the airplane is within the allowable limits.

Intentionally left blank

6.4 - Determining weight and balance

General

This section is intended to provide the pilot with the procedure to determine the weight and balance of the airplane.

▲ WARNING ▲

It is the pilot's responsibility to ensure that the airplane is properly loaded and that the weight and balance limits are adhered to.



The procedure requires the following data related to the basic characteristics of the empty airplane to be obtained from the last airplane weight and balance report :

- the empty weight, expressed in kg or lbs,
- the moment, expressed in m.kg or in.lbs,
- the CG, expressed in MAC %

If the airplane empty weight has varied since last weight and balance report (for example, due to installation of optional equipment), refer to paragraph Determining empty airplane characteristics to determine new empty weight and the corresponding moment.

Utilization of weight and balance graph

This procedure determines the airplane weight and balance characteristics for flight.

Select the units for the weight and balance determination, either m and kg, or lb and in, and use the dedicated form - see figures 6.4.3 to 6.4.6, appropriate to the chosen units.

- 1) Record the basic empty weight (1a), moment (1b) and CG (MAC %) (1c) from the last weight and balance report - see sample of weight and balance report, figures 6.4.1 and 6.4.2.
- 2) Record the expected loading (2a) and compute each associated moment (2b).
- 3) Compute zero fuel weight (3a) and moment (3b) as sum of all the above weights (1a)+(2a) and moments (1b) + (2b).
- 4) Check value (3a) to be below maximum zero fuel weight.
- 5) Compute zero fuel weight arm (5) and CG (MAC %) (5c) using given formulas.
- 6) Record the loaded fuel (6a) and compute associated moment (6b).
- 7) Compute ramp weight (7a) and moment (7b) as sum of zero fuel weight (3a) + loaded fuel (6a) and moments (3b) + (6b).
- 8) Check value (7a) to be below maximum ramp weight.
- 9) Compute ramp weight arm (9) and CG (MAC %) (9c) using given formulas.
- 10) Record the expected taxi fuel (negative value) (10a) and compute associated moment (10b).
- 11) Compute takeoff weight (11a) and moment (11b) as sum of ramp weight (7a) + taxi fuel (10a) and moments (7b) + (10b).
- 12) Check value (11a) to be below maximum takeoff weight.
- 13) Compute takeoff weight arm (13) and CG (MAC %) (13c) using given formulas.
- 14) Record the expected trip fuel (negative value) (14a) and compute associated moment (14b).
- 15) Compute landing weight (15a) and moment (15b) as sum of takeoff weight (11a) + trip fuel (14a) and moments (11b) + (14b).
- 16) Check value (15a) to be below maximum landing weight.
- 17) Compute landing weight arm (17) and CG (MAC %) (17c) using given formulas.
- 18) Plot zero fuel weight, takeoff weight and landing weight on weight and balance diagram.

- 19) Check that all points are within the weight and balance limits and check that they are vertically aligned.
- 20) Record these data on your navigation log.

Airplane loading form (m, kg)

Moment = Weight x Arm $CG (MAC \%) = \frac{(Arm (m) - 4.392)}{1.51} \times 100$

>> Up to S/N 1159

Item	Weight (kg)	Arm (m)	Moment (m.kg)	CG (MAC %)
Empty weight (kg)	(1a)		(1b)	(1c)
Baggage FWD (< 50 kg)	(2a)	3.250	(2b)	
Front seats (kg)	(2a)	4.534	(2b)	
Inter. seats	-17.5 kg per seat removed	5.710	(2b)	
	Pax		(2b)	
Rear bench/net	-24 kg per seat removed	6.785	(2b)	
	Pax		(2b)	
	Cargo (< 80 kg)		(2b)	
Baggage AFT (< 100 kg)	(2a)	7.695	(2b)	
Zero fuel weight (< 2736 kg)	(3a)	(5)	(3b)	(5c)
Fuel (kg)	(6a)	4.820	(6b)	
Ramp weight (< 3370 kg)	(7a)	(9)	(7b)	(9c)
Taxi fuel (kg)	(10a)	4.820	(10b)	
Takeoff weight (< 3354 kg)	(11a)	(13)	(11b)	(13c)
Trip fuel (kg)	(14a)	4.820	(14b)	
Landing weight (< 3186 kg)	(15a)	(17)	(17)	(17c)

>> Up to S/N 1159

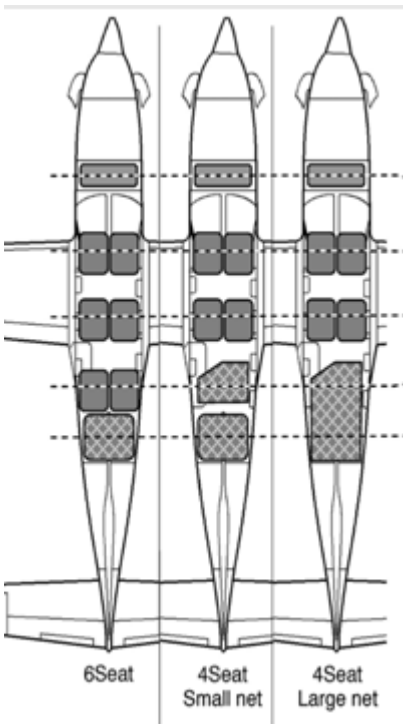

Item		Weight (kg)
Empty weight		(1a)
Baggage FWD	(< 50 kg)	(2a)
Front seats		(2a)
Inter. seats	-17.5 kg per seat removed	(2a)
	Pax	(2a)
Rear bench/net	-24 kg per seat removed	(2a)
	Pax	(2a)
	Cargo (< 80 kg)	(2a)
Baggage AFT	(< 100 kg)	(2a)

Moment = Weight x Arm

$$CG (MAC \%) = \frac{(Arm (m) - 4.392)}{1.51} \times 100$$

>> From S/N 1160

Item	Weight (kg)	Arm (m)	Moment (m.kg)	CG (MAC %)
Empty weight (kg)	(1a)		(1b)	(1c)
Baggage FWD (< 50 kg)	(2a)	3.250	(2b)	
Front seats (kg)	(2a)	4.534	(2b)	
Inter. seats	-15 kg per seat removed *	5.710	(2b)	
	Pax		(2b)	
Rear bench/net	-20.5 kg per seat removed *	6.785	(2b)	
	Pax		(2b)	
	Cargo (< 80 kg)		(2b)	
Baggage AFT (< 100 kg)	(2a)	7.695	(2b)	
Zero fuel weight (< 2736 kg)	(3a)	(5)	(3b)	(5c)
Fuel (kg)	(6a)	4.820	(6b)	
Ramp weight (< 3370 kg)	(7a)	(9)	(7b)	(9c)
Taxi fuel (kg)	(10a)	4.820	(10b)	
Takeoff weight (< 3354 kg)	(11a)	(13)	(11b)	(13c)
Trip fuel (kg)	(14a)	4.820	(14b)	
Landing weight (< 3186 kg)	(15a)	(17)	(17)	(17c)

* Seats weights do not include seat heating system

>> From S/N 1160

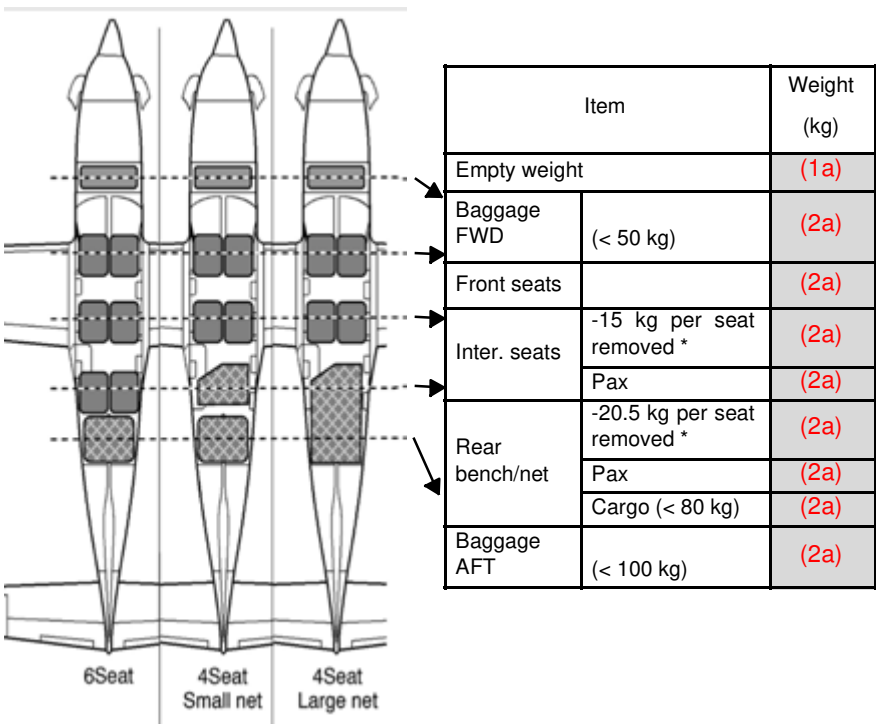

* Seats weights do not include seat heating system

Example of airplane weight and balance report

• NOTE •

Airplane original report shall be kept with airplane POH

REGISTRE INDIVIDUEL DE CONTROLE INDIVIDUAL INSPECTION RECORD		TBM 700																				
FICHE DE PESEE CONFIGURATION 6 PLACES		S/N : F : 8																				
Mise de niveau :	Rails de sieges	SEULEMENT POUR INFORMATION, SE REFERER A LA LIMITATION DU MANUEL DE VOL SECTION 2																				
<p>Point de levage avant</p> <p>Points de levage gauche et droit</p>	<p>LIMITATION</p> <p>Masse max au décollage : 3354 Kg H</p> <p>Masse max à l'atterrissage : 3186 Kg H</p> <p>Centrage (trains sortis et volets rentrés)</p> <p>2000 Kg 14 à 35,5 % H</p> <p>2835 Kg 18 à 35,5 % H</p> <p>2864 Kg 20 à 35,5 % H</p>																					
	<p>PESEE EFFECTUEE SUR POINTS DE LEVAGE</p> <p>Avion non peint Sans huile moteur</p> <table border="1"> <thead> <tr> <th>Point</th> <th>Masse (Kg)</th> <th>Force (Kg)</th> <th>Masse (Kg)</th> </tr> </thead> <tbody> <tr> <td>Point gauche</td> <td>793,5</td> <td>P1</td> <td>P2</td> </tr> <tr> <td>Point droit</td> <td>825</td> <td>P2</td> <td>P3</td> </tr> <tr> <td>Point avant</td> <td>499,5</td> <td>P3</td> <td>P0</td> </tr> </tbody> </table> <p>Masse P0 (Kg) = 2119,0</p>		Point	Masse (Kg)	Force (Kg)	Masse (Kg)	Point gauche	793,5	P1	P2	Point droit	825	P2	P3	Point avant	499,5	P3	P0	<p>DISTANCE DU C.G. A LA REFERENCE</p> $d0 = \frac{(P1 \times d1) + (P2 \times P3) \times d2}{P0}$ $d0 = \frac{(499,5 \times 2,085) + (793,5 + 825) \times 5,297}{2119,0} = 4,752$			
Point	Masse (Kg)	Force (Kg)	Masse (Kg)																			
Point gauche	793,5	P1	P2																			
Point droit	825	P2	P3																			
Point avant	499,5	P3	P0																			
<p>CORRECTION</p> <table border="1"> <thead> <tr> <th>Masse (Kg)</th> <th>bras (m)</th> <th>Moment (m * Kg)</th> </tr> </thead> <tbody> <tr> <td>Masse P0</td> <td>2119,0</td> <td>4,752</td> <td>10064,74</td> </tr> <tr> <td>Peinture (2)</td> <td>30</td> <td>4,873</td> <td>146,19</td> </tr> <tr> <td>Huile moteur (3)</td> <td>11,2</td> <td>2,09</td> <td>23,41</td> </tr> <tr> <td>Carburant inconnu</td> <td>(1a) 27,2</td> <td>4,7</td> <td>127,84</td> </tr> </tbody> </table>		Masse (Kg)	bras (m)	Moment (m * Kg)	Masse P0	2119,0	4,752	10064,74	Peinture (2)	30	4,873	146,19	Huile moteur (3)	11,2	2,09	23,41	Carburant inconnu	(1a) 27,2	4,7	127,84	<p>CENTRAGE A VIDE (EN % DE LA CMA)</p> $CG = \frac{d0 - 4,392}{1,51} \times 100$ $CG = \frac{4,751 - 4,392}{1,51} \times 100 = 23,8$	
Masse (Kg)	bras (m)	Moment (m * Kg)																				
Masse P0	2119,0	4,752	10064,74																			
Peinture (2)	30	4,873	146,19																			
Huile moteur (3)	11,2	2,09	23,41																			
Carburant inconnu	(1a) 27,2	4,7	127,84																			
<p>RESULTATS W: 2145,2 D0: 4,751 M: 10192,58 (1b)</p>																						
<p>CALCUL DE L'INDEX DE BASE Cf section 6 du manuel de vol</p> <p>Masse à vide (W) : 2145,2 Kg (1a)</p> <p>Centrage à Vide (CG) : 23,8 % (1c)</p> <p>Moment (M) : 10192,58</p>																						
<p>1 - Rayer la mention inutile. 2 - Valeur non prise en compte si l'avion était peint lors de la pesée. 3 - Valeur non prise en compte si l'avion a été pesé avec huile.</p>																						
DATE :		VISA DE CONTRÔLE :																				

Figure 6.4.1 - Example of weight and balance report and basic airplane characteristics, in kg and m

• NOTE •

Airplane original report shall be kept with airplane POH

REGISTRE INDIVIDUEL DE CONTROLE INDIVIDUAL INSPECTION RECORD		TBM 700																
WEIGHT AND BALANCE REPORT		S/N :																
6-SEAT CONFIGURATION		F : 6																
<p>Leveling : </p> <p>WEIGHING CARRIED OUT ON JACK POINTS</p>		<p>ONLY FOR INFORMATION, REFER TO LIMITATIONS SECTION 2 OF POH</p> <p>LIMITATIONS</p> <p>Maximum take off weight : 7394.3 lbs H</p> <p>Maximum landing weight : 7024 lbs H</p> <p>Balance (landing gear down and flaps up)</p> <table border="0"> <tr> <td>4400 lbs</td> <td>44 - 35.5 %</td> <td rowspan="3">H</td> </tr> <tr> <td>6250 lbs</td> <td>48 - 35.5 %</td> </tr> <tr> <td>6579 lbs</td> <td>20 - 35.5 %</td> </tr> </table>		4400 lbs	44 - 35.5 %	H	6250 lbs	48 - 35.5 %	6579 lbs	20 - 35.5 %								
4400 lbs	44 - 35.5 %	H																
6250 lbs	48 - 35.5 %																	
6579 lbs	20 - 35.5 %																	
<p>Not painted airplane Without engine oil</p> <table border="1"> <thead> <tr> <th>Weight (lb)</th> <th>Arm (in)</th> <th>Moment (in" lb)</th> </tr> </thead> <tbody> <tr> <td>1749.4</td> <td>187.0</td> <td>327156.8</td> </tr> <tr> <td>1818.8</td> <td>191.8</td> <td>348992.2</td> </tr> <tr> <td>1101.2</td> <td>62.3</td> <td>68604.8</td> </tr> <tr> <td>Weight PO (lb) =</td> <td>4669.4</td> <td>744953.8</td> </tr> </tbody> </table> <p>Weight PO (lb) = 4669.4</p>		Weight (lb)	Arm (in)	Moment (in" lb)	1749.4	187.0	327156.8	1818.8	191.8	348992.2	1101.2	62.3	68604.8	Weight PO (lb) =	4669.4	744953.8	<p>Distance from C.G. TO REFERENCE</p> $(P1 \times d1) + (P2 + P3) \times d2$ $\frac{(1101.2 \times 117.5) + (1749.4 + 1818.8) \times 208.5}{4669.4} = 187.0$	
Weight (lb)	Arm (in)	Moment (in" lb)																
1749.4	187.0	327156.8																
1818.8	191.8	348992.2																
1101.2	62.3	68604.8																
Weight PO (lb) =	4669.4	744953.8																
<p>CORRECTIONS</p> <table border="1"> <thead> <tr> <th>Weight (lb)</th> <th>Arm (in)</th> <th>Moment (in" lb)</th> </tr> </thead> <tbody> <tr> <td>Weight PO</td> <td>4669.4</td> <td>744953.8</td> </tr> <tr> <td>Paint (2)</td> <td>65.2</td> <td>12697.2</td> </tr> <tr> <td>Engine oil (3)</td> <td>68.3</td> <td>2632.8</td> </tr> <tr> <td>Unusable fuel</td> <td>60</td> <td>11100.0</td> </tr> </tbody> </table>		Weight (lb)	Arm (in)	Moment (in" lb)	Weight PO	4669.4	744953.8	Paint (2)	65.2	12697.2	Engine oil (3)	68.3	2632.8	Unusable fuel	60	11100.0	<p>BALANCE MAC (%)</p> $CG = \frac{D0 - 173}{59.5} \times 100$ $CG = \frac{187 - 173}{59.5} \times 100 = 23.8$	
Weight (lb)	Arm (in)	Moment (in" lb)																
Weight PO	4669.4	744953.8																
Paint (2)	65.2	12697.2																
Engine oil (3)	68.3	2632.8																
Unusable fuel	60	11100.0																
<p>RESULTS W: 4729.4 D0: 187 M: 884460.7 (1b)</p>																		
<p>BASIC INDEX CALCULATION See section 6 of Pilot's Operating Handbook</p> <p>Empty weight (W) : 4729.4 lb (1a)</p> <p>Balance (CG) : 23.8 % (1c)</p> <p>Moment (M) : 884460.7</p>																		
<p>1 - Scratch useless mention. 2 - Values not taken into account if the airplane was painted when weighed. 3 - Values not taken account if the oil tank was full when the airplane was weighed.</p> <p>DATE : INSPECTION VISA :</p>																		

Figure 6.4.2 - Example of weight and balance report and basic airplane characteristics, in lb and in

Weight and balance form and diagram (m, kg)

Moment = Weight x Arm

$$CG (MAC \%) = \frac{(Arm (m) - 4.392)}{1.51} \times 100$$

>> Up to S/N 1159

Item		Weight (kg)	Arm (m)	Moment (m.kg)	CG (MAC %)
Empty weight (kg)					
Baggage FWD (< 50 kg)			3.250		
Front seats (kg)			4.534		
Inter. seats	- 17.5 kg per seat removed		5.710		
	Pax				
Rear bench/net	- 24 kg per seat removed		6.785		
	Pax				
	Cargo (< 80 kg)				
Baggage AFT (< 100 kg)			7.695		
Zero fuel weight (< 2736 kg)					
Fuel (kg)			4.820		
Ramp weight (< 3370 kg)					
Taxi fuel (kg)			4.820		
Takeoff weight (< 3354 kg)					
Trip fuel (kg)			4.820		
Landing weight (< 3186 kg)					

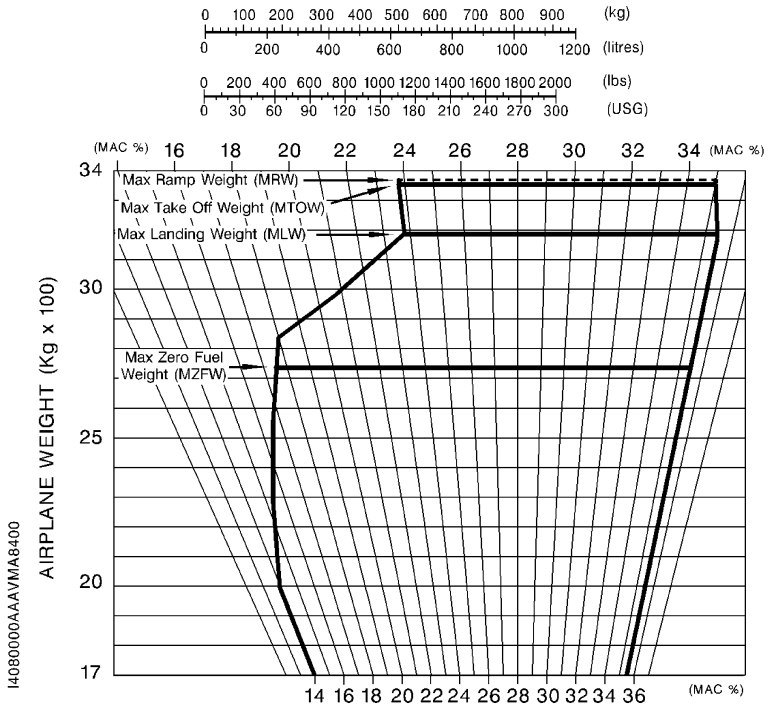

Figure 6.4.3 - Weight and balance diagram

Moment = Weight x Arm

$$CG (MAC \%) = \frac{(Arm (m) - 4.392)}{1.51} \times 100$$

>> From S/N 1160

Item	Weight (kg)	Arm (m)	Moment (m.kg)	CG (MAC %)
Empty weight (kg)				
Baggage FWD (< 50 kg)		3.250		
Front seats (kg)		4.534		
Inter. seats	- 15 kg per seat removed *	5.710		
	Pax			
Rear bench/net	- 20.5 kg per seat removed *	6.785		
	Pax			
	Cargo (< 80 kg)			
Baggage AFT (< 100 kg)		7.695		
Zero fuel weight (< 2736 kg)				
Fuel (kg)		4.820		
Ramp weight (< 3370 kg)				
Taxi fuel (kg)		4.820		
Takeoff weight (< 3354 kg)				
Trip fuel (kg)		4.820		
Landing weight (< 3186 kg)				

* Seats weights do not include seat heating system

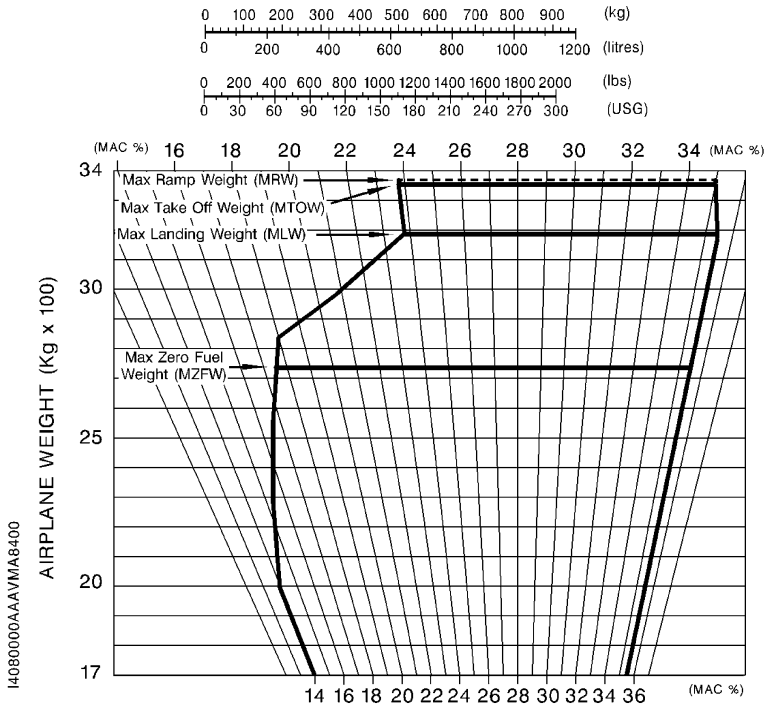

Figure 6.4.4 - Weight and balance diagram

Weight and balance form and diagram (in, lbs)

Moment = Weight x Arm $CG (MAC\%) = \frac{(Arm (in) - 172.93)}{59.45} \times 100$

>> Up to S/N 1159

Item	Weight (lbs)	Arm (in)	Moment (in.lbs)	CG (MAC %)
Empty weight (lbs)				
Baggage FWD (< 110 lbs)		128.0		
Front seats (lbs)		178.5		
Inter. seats	- 38.6 lbs per seat removed	224.8		
	Pax			
Rear bench/net	- 52.9 lbs per seat removed	267.1		
	Pax			
	Cargo (< 176 lbs)			
Baggage AFT (< 220 lbs)		303.0		
Zero fuel weight (< 6032 lbs)				
Fuel (lbs)		189.8		
Ramp weight (< 7430 lbs)				
Taxi fuel (lbs)		189.8		
Takeoff weight (< 7394 lbs)				
Trip fuel (lbs)		189.8		
Landing weight (< 7024 lbs)				

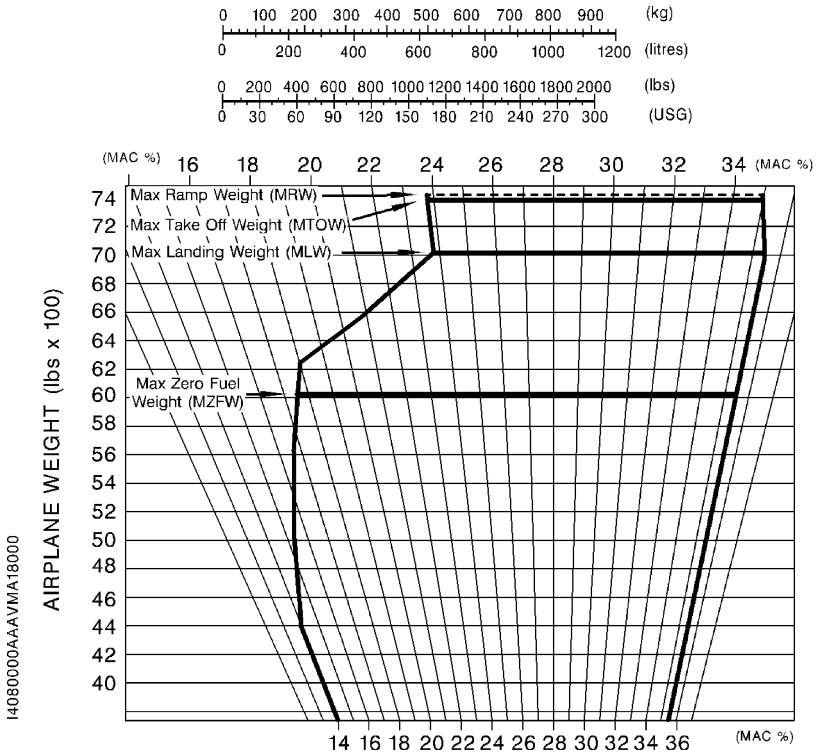

Figure 6.4.5 - Weight and balance diagram

Moment = Weight x Arm

$$CG (MAC \%) = \frac{(Arm (in) - 172.93)}{59.45} \times 100$$

>> From S/N 1160

Item	Weight (lbs)	Arm (in)	Moment (in.lbs)	CG (MAC %)
Empty weight (lbs)				
Baggage FWD (< 110 lbs)		128.0		
Front seats (lbs)		178.5		
Inter. seats	- 33.1 lbs per seat removed *	224.8		
	Pax			
Rear bench/net	- 45.2 lbs per seat removed *	267.1		
	Pax			
	Cargo (< 176 lbs)			
Baggage AFT (< 220 lbs)		303.0		
Zero fuel weight (< 6032 lbs)				
Fuel (lbs)		189.8		
Ramp weight (< 7430 lbs)				
Taxi fuel (lbs)		189.8		
Takeoff weight (< 7394 lbs)				
Trip fuel (lbs)		189.8		
Landing weight (< 7024 lbs)				

* Seats weights do not include seat heating system

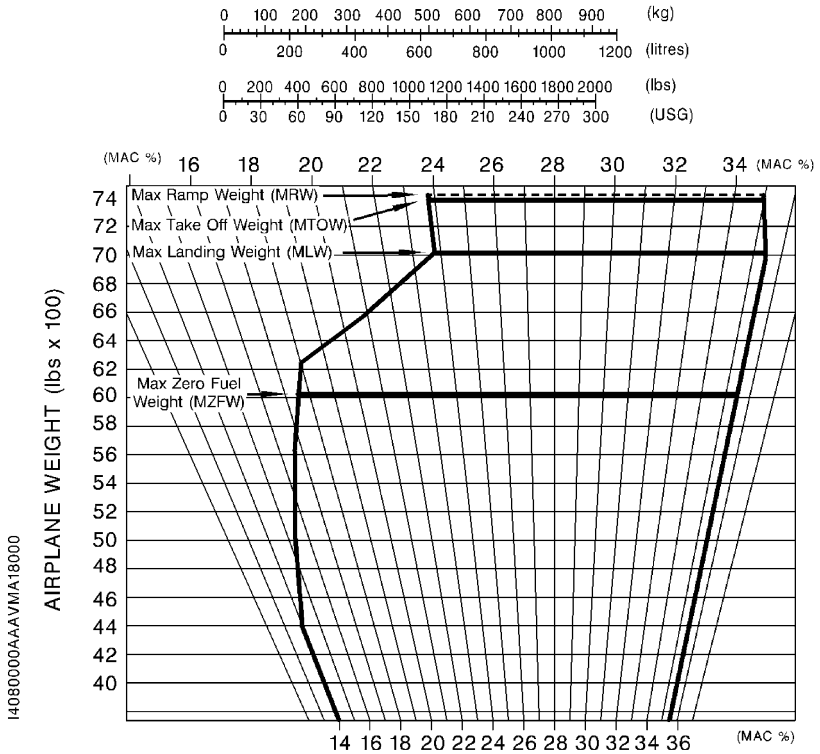

Figure 6.4.6 - Weight and balance diagram

Intentionally left blank

Weight and balance samples (m, kg)

>> Up to S/N 1159

▲ CAUTION ▲

Loading samples - see figure 6.4.7 or 6.4.8 - are only given as an example ; for calculation concerning your airplane, refer to the diagram corresponding to its validity.



	Fig. 6.4.5
1 - Airplane basic characteristics :	
W = Empty weight	2 126 kg
Moment	10 073 m.kg
Balance arm	4.738 m
CG (MAC %)	22.9 %
2 - Foreseen loading :	
1 Pilot and 1 front passenger	200 kg
2 Rear passengers	160 kg
AFT Cargo in baggage compartment	50 kg
Fuel	820 kg
3 - Foreseen fuel :	
Taxi fuel	- 16 kg
Trip fuel	- 600 kg

Moment = Weight x Arm

$$CG (MAC \%) = \frac{(Arm (m) - 4.392)}{1.51} \times 100$$

>> Up to S/N 1159

Item	Weight (kg)	Arm (m)	Moment (m.kg)	CG (MAC %)	
Empty weight (kg)	2 126	4.738	10 073	22.9	
Baggage FWD (< 50 kg)	0	3.250	0		
Front seats (kg)	200	4.534	907		
Inter. seats	- 17.5 kg per seat removed	5.710	0		
	Pax		0		
Rear bench/net	- 24 kg per seat removed	6.785	0		
	Pax		160		1 086
	Cargo (< 80 kg)		0		0
Baggage AFT (< 100 kg)	50	7.695	385		
Zero fuel weight (< 2736 kg)	2 536	4.910	12 451	34.3	
Fuel (kg)	820	4.820	3 952		
Ramp weight (< 3370 kg)	3 356	4.888	16 403	32.8	
Taxi fuel (kg)	- 16	4.820	- 77		
Takeoff weight (< 3354 kg)	3 340	4.888	16 326	32.8	
Trip fuel (kg)	- 600	4.820	- 2 892		
Landing weight (< 3186 kg)	2 740	4.903	13 434	33.8	

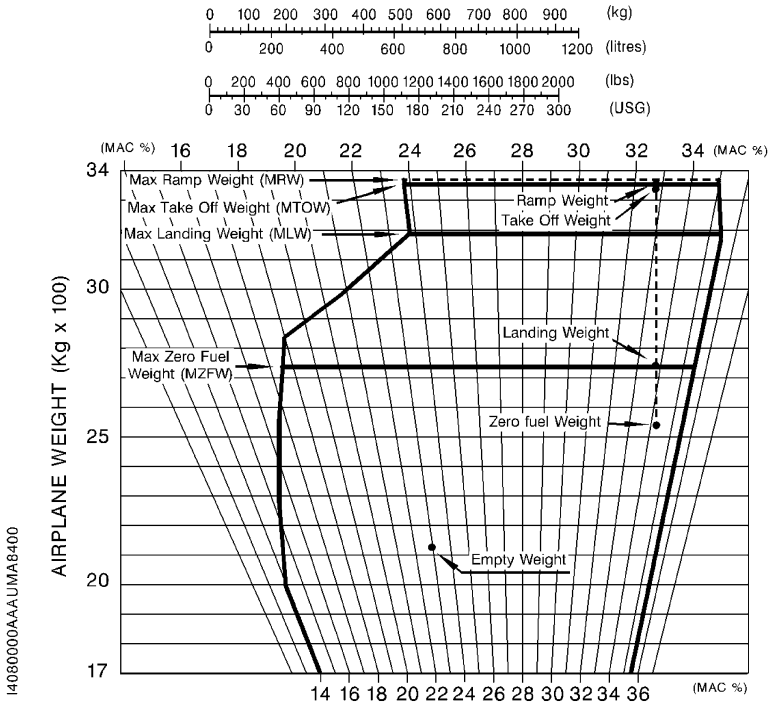

1408000AAAUMAB400

Figure 6.4.7 - Loading sample (in kg and m)

Intentionally left blank

Weight and balance samples (in, lbs)

■ >> From S/N 1160

▲ **CAUTION** ▲

■ Loading samples - see figure 6.4.7 or 6.4.8 - are only given as an example ; for calculation concerning your airplane, refer to the diagram corresponding to its validity.



	Fig. 6.4.6
1 - Airplane basic characteristics :	
W = Empty weight	4 638 lbs
Moment	864 173 in.lbs
Balance arm	186.3 in
CG (MAC %)	22.6 %
2 - Foreseen loading :	
FWD compartment	0 lbs
1 Pilot and 1 front passenger	400 lbs
1 Intermediate passenger	220 lbs
2 Rear seats removed	- 92.4 lbs
Rear cargo	176 lbs
AFT Cargo in baggage compartment	220 lbs
Fuel	1 850 lbs
3 - Foreseen fuel :	
Taxi fuel	- 36 lbs
Trip fuel	- 1 400 lbs

Moment = Weight x Arm

$$CG (MAC \%) = \frac{(Arm (in) - 172.93)}{59.45} \times 100$$

■ >> From S/N 1160

Item		Weight (lbs)	Arm (in)	Moment (in.lbs)	CG (MAC %)
Empty weight (lbs)		4 638	186.3	864 173	22.6
Baggage FWD (< 110 lbs)		0	128.0	0	
Front seats (lbs)		400	178.5	71 400	
Inter. seats	- 34 lbs per seat removed *	0	224.8	0	
	Pax	220		49 456	
Rear bench/net	- 46.2 lbs per seat removed *	- 92.4	267.1	- 24 680	
	Pax	0		0	
	Cargo (< 176 lbs)	176		47 010	
Baggage AFT (< 220 lbs)		220	303.0	66 660	
Zero fuel weight (< 6032 lbs)		5 562	193.1	1 074 019	33.9
Fuel (lbs)		1 850	189.8	351 130	
Ramp weight (< 7430 lbs)		7 412	192.3	1 425 149	32.6
Taxi fuel (lbs)		- 36	189.8	- 6 833	
Takeoff weight (< 7394 lbs)		7 376	192.3	1 418 316	32.6
Trip fuel (lbs)		- 1 400	189.8	- 265 720	
Landing weight (< 7024 lbs)		5 976	192.9	1 152 596	33.6

* Seats weights include seat heating system

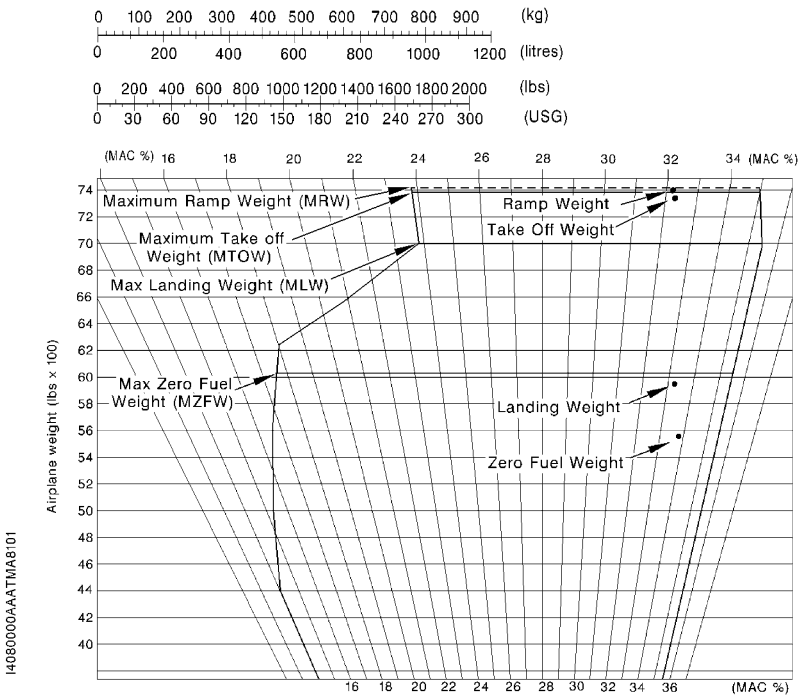

Figure 6.4.8 - Loading samples (in lbs and in)

Determining empty airplane characteristics

Empty airplane characteristics (weight and balance) may vary with regard to those indicated on weighing form according to installed optional equipment and installed seats.

List of equipment (refer to chapter 6.5) contains the standard and optional equipment, as well as their characteristics (weight, arm), except those listed in this Chapter.

Use the chart below to compute new empty weight and corresponding balance if necessary.

Date	Equipment or modification description	(+) (-)	Weight modification			Basic empty weight		
			Weight lb	Arm in.	Moment lb.in/1000	Weight W	Arm "d _o "	Moment
	According to delivery							

Figure 6.4.9 - Sample weight and balance record

$$CG \text{ m.a.c.\%} = \frac{(d_o - 172.93)}{59.45} \times 100$$

Use the above formula to express arm "d_o" in % of mean aerodynamic chord.

• NOTE •

Arm expressed in inches with regard to reference.



FWD baggage compartment : 128.0 in. (3.250 m)

Baggage compartment in pressurized cabin : 303.0 in. (7.695 m)

Fuel : 189.8 in. (4.820 m)

S/ R/ A/ O	Item OPT70 or MOD70	Required (R) or Standard (S) or Optional (A or O) equipment	Weight per unit lb (kg)	Arm in. (m)
		10 - Parking, mooring, storage and return to service		
		Board kit		
S		- Blanking caps bag	8.31 (3.77)	128.00 (3.250)
S		- Towing bar	8.77 (3.98)	128.00 (3.250)
S		- Control lock device	0.90 (0.41)	133.86 (3.400)
		25 - Equipment and furnishings (partial)		
S	0503-25A	- Upholstery Version 2016, of which :	$\Delta + 2.73$ ($\Delta + 1.24$)	228.30 (5.799)
		. Carpets for 6-place configuration	26.68 (12.100)	/
		. Carpets for 4-place configuration	20.59 (9.340)	/
A	0503-25A	- Generation 2008 cabinets :		
		. L.H. low storage	9.48 (4.300)	203.74 (5.175)
		. R.H. low storage	9.48 (4.300)	203.74 (5.175)
		. L.H. low + high storage	17.20 (7.800)	203.74 (5.175)
		. R.H. low + high storage	17.20 (7.800)	203.74 (5.175)
		. L.H. low + top pilot case support	9.70 (4.400)	203.74 (5.175)

S/ R/ A/ O	Item OPT70 or MOD70	Required (R) or Standard (S) or Optional (A or O) equipment	Weight per unit lb (kg)	Arm in. (m)
		. R.H. low + top pilot case support	9.70 (4.400)	203.74 (5.175)
S	0557-25A	- Upholstery Version 2017, of which :	Δ Neglig.	/
		. Carpets for 6-place configuration	26.68 (12.100)	/
		. Carpets for 4-place configuration	20.59 (9.340)	/
A	0557-25A	- Generation 2008 cabinets - From S/N 1160 to S/N 1269 :		
		. L.H. low storage	9.48 (4.300)	203.74 (5.175)
		. R.H. low storage	9.48 (4.300)	203.74 (5.175)
		. L.H. low + high storage	17.20 (7.800)	203.74 (5.175)
		. R.H. low + high storage	17.20 (7.800)	203.74 (5.175)
		. L.H. low + top pilot case support	9.70 (4.400)	203.74 (5.175)
		. R.H. low + top pilot case support	9.70 (4.400)	203.74 (5.175)
		Leather seats		
S		- L.H. intermediate seat (back to or in flight direction) - Up to S/N 1159	38.58 (17.50)	224.80 (5.710)
S	0553-25A	- L.H. intermediate seat (back to or in flight direction) - From S/N 1160 to S/N 1214	33.07 (15.00)	224.80 (5.710)
S	0588-25	- L.H. intermediate seat with seats heaters system (back to or in flight direction) - From S/N 1215	34.06 (15.45)	224.80 (5.710)

S/ R/ A/ O	Item OPT70 or MOD70	Required (R) or Standard (S) or Optional (A or O) equipment	Weight per unit lb (kg)	Arm in. (m)
S		- R.H. intermediate seat (back to or in flight direction) - Up to S/N 1159	38.58 (17.50)	224.80 (5.710)
S	0553-25A	- R.H. intermediate seat (back to or in flight direction) - From S/N 1160 to S/N 1214	33.07 (15.00)	224.80 (5.710)
S	0588-25	- R.H. intermediate seat with seats heaters system (back to or in flight direction) - From S/N 1215	34.06 (15.45)	224.80 (5.710)
		- Double chair		
		. L.H. Seat - Up to 1159	52.91 (24.00)	278.19 (7.066)
S	0553-25A	. L.H. seat - From S/N 1160 to S/N 1214	45.20 (20.50)	278.62 (7.077)
S	0588-25	. L.H. seat, with seats heaters system - From S/N 1215	46.25 (20.98)	278.62 (7.077)
		. R.H. Seat - Up to 1159	52.91 (24.00)	278.19 (7.066)
	0553-25A	. R.H. seat - From S/N 1160 to S/N 1214	45.20 (20.50)	278.62 (7.077)
S	0588-25	. R.H. seat, with seats heaters system - From S/N 1215	46.25 (20.98)	278.62 (7.077)
		Nets		
S	0315-25	- Small cargo net GP SOCT704CC-10	15.00 (7.00)	/
S	0315-25	- Large cargo net GP SOCT704CS-10	13.00 (6.00)	/
S	25026B	Partition net at Frame 14 (between the cabin and the baggage compartment) T700B2590001 of which	3.64 (1.65)	289.53 (7.354)
		- Partition net	1.70 (0.77)	289.53 (7.354)

Intentionally left blank

6.5 - List of equipment

The list of equipment is available in manufacturer Report reference NAV No.34/90-RJ-App 6, located at the end of this POH.

A separate list of equipment of items installed at the factory in your specific airplane is provided in your airplane file.

Intentionally left blank

Section 7

Description

Table of contents

7.1	-	General	7.1.1
7.2	-	Airframe	7.2.1
		Wings	7.2.5
		Ailerons, spoilers and pitch trim tab	7.2.5
		Wing flaps	7.2.5
		Empennages	7.2.5
7.3	-	Accommodations	7.3.1
		Instrument panel	7.3.1
		Doors, windows and emergency exit	7.3.20
		Seats, belts and harnesses	7.3.28
		Baggage compartments	7.3.34
		Use of cargo nets	7.3.37
7.4	-	Flight controls	7.4.1
		Roll	7.4.1
		Roll trim	7.4.1
		Elevator	7.4.6
		Pitch trim	7.4.6
		Rudder	7.4.11
		Rudder trim	7.4.11
7.5	-	Landing gear	7.5.1
		Hydraulic pressure	7.5.1
		Landing gear lever	7.5.1
		Landing gear position indicator	7.5.2
		Safety	7.5.4
		Ground maneuvers	7.5.6
		Brake system	7.5.9
		Parking brake	7.5.9

7.6	-	Powerplant	7.6.1
		Turboprop engine operation	7.6.1
		Engine control levers	7.6.4
		Engine instruments	7.6.7
		Engine lubrication	7.6.7
		Engine starting	7.6.8
		Engine air inlet	7.6.10
		Exhaust system	7.6.10
		Engine accessories	7.6.10
		Propeller	7.6.12
7.7	-	Fuel system	7.7.1
		Fuel tanks	7.7.1
		Fuel unit	7.7.1
		Tank manual selector	7.7.1
		Automatic tank selector	7.7.4
		Electric boost pump (AUX BP)	7.7.5
		Main mechanical boost pump	7.7.8
		Engine fuel system	7.7.8
		Fuel gaging installation	7.7.8
		Fuel system monitoring	7.7.8
		Fuel system draining and clogging indicator	7.7.9
7.8	-	Electrical system	7.8.1
		Starter generator	7.8.1
		Stand-by generator	7.8.2
		Battery	7.8.2
		Ground power receptacle	7.8.2
		Distribution	7.8.3
		Emergency use	7.8.4
		Indicating	7.8.15
		Protection - safety	7.8.15
		Exterior lighting	7.8.17
		Interior lighting	7.8.20
7.9	-	Air conditioning and pressurization	7.9.1
		Engine bleed air system	7.9.2
		Cabin pressurization control system	7.9.3
		Dual-zone environmental control system	7.9.6

Pilot's Operating Handbook

7.10	-	Emergency oxygen system	7.10.1
		Flight above 15000 ft with possible emergency descent	7.10.4
		When required to remain above 15000 ft due to minimum enroute altitude	7.10.5
		Flight between 15000 ft and 10000 ft	7.10.6
		O ₂ smart mike mask, if installed	7.10.7
7.11	-	Air data system and instruments	7.11.1
		Static pressure systems	7.11.1
		Dynamic pressure system	7.11.2
7.12	-	Vacuum system and instruments	7.12.1
		Standby attitude module (MD302)	7.12.1
7.13	-	Ice protection equipment	7.13.1
		Wing and empennage deicing	7.13.1
		Propeller deicing	7.13.2
		Windshield deicing	7.13.2
		Heating of pitots and stall warning sensor (PITOT L HTR and PITOT R & STALL HTR)	7.13.3
		Turbine air inlet protection	7.13.3
7.14	-	Miscellaneous equipment	7.14.1
		Stall warning system	7.14.1
		Static dischargers	7.14.2
		Cabin fire extinguisher	7.14.2
		Autopilot	7.14.2
		GPS	7.14.2
		Weather radar GWX 70	7.14.3
		Emergency locator transmitter	7.14.6
		Lightweight data recorder (LDR 1000)	7.14.7
		ADS-B OUT function	7.14.8
		Flight deck information system (FS 510), if installed	7.14.8
		Data collection and transmission system (FASTBOX), if installed	7.14.9
		GARMIN Integrated Flight Deck (GIFD) approaches	7.14.9
		Optional equipment	7.14.15

Intentionally left blank

7.1 - General

This section provides description and operation of the airplane and its systems.

Some of the equipment described herein is optional and may not be installed in the airplane.

Complete description and operation of the GARMIN integrated flight deck are detailed in the GARMIN Integrated Flight Deck Pilot's Guide. References to this guide are often made all along this section to get more details about some systems.

Details of other optional systems and equipment are presented in section 9 Supplements of the POH.

Intentionally left blank

7.2 - Airframe - see figures 7.2.1, 7.2.1A and 7.2.1B

This airplane is a six-place, low wing airplane.

The airplane can be changed into 2, 3, 4 or 5-seat accommodation.

The structure is a semi-monocoque all-metal construction and is equipped with a retractable tricycle landing gear.

The pressurized cabin is equipped, on the left side of fuselage, with a one-piece access door and folding stairs comprising a hand rail allowing pilot and passengers boarding. The occupants have access to cockpit and to rear seats through a central aisle.

An optional pilot door located forward of the cabin on the left side allows access to the cockpit by means of folding stairs.

The aft cabin section is a baggage compartment.

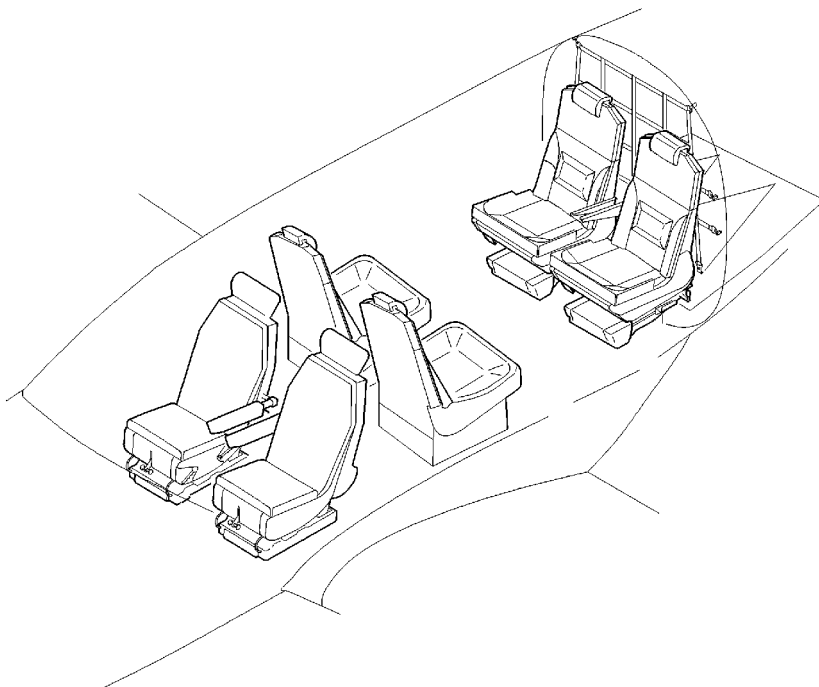

14251201AAAKMA8000

Figure 7.2.1 - Cabin arrangement
6-seat accommodation

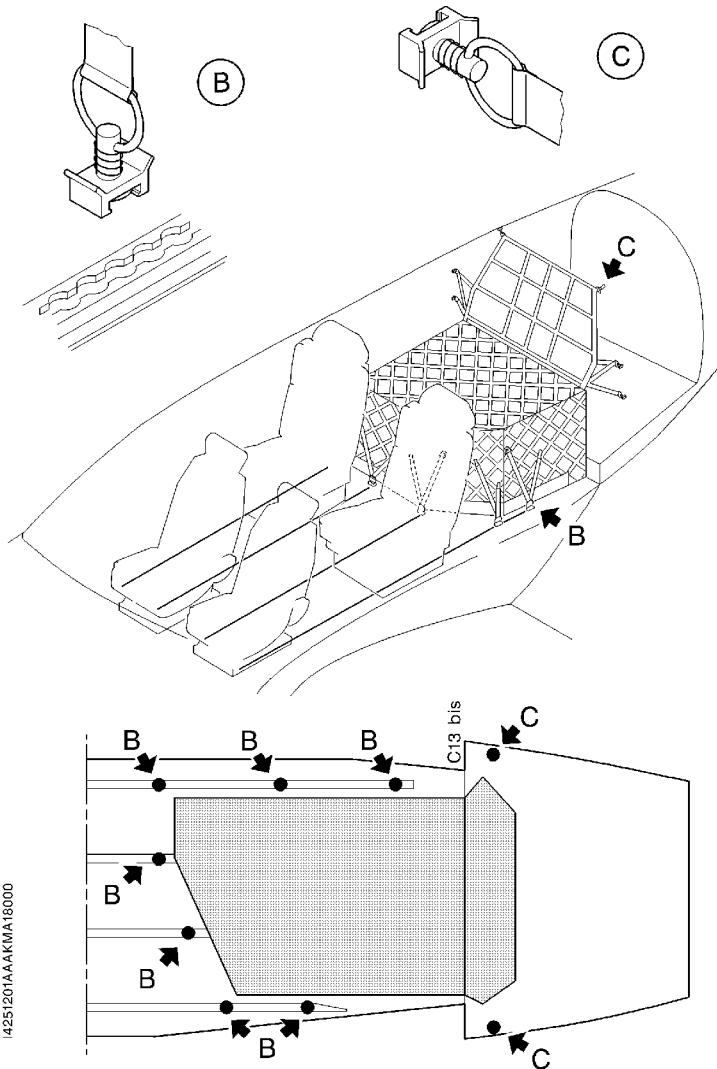

Figure 7.2.1A - Cabin arrangement
4-seat accommodation with large securing net

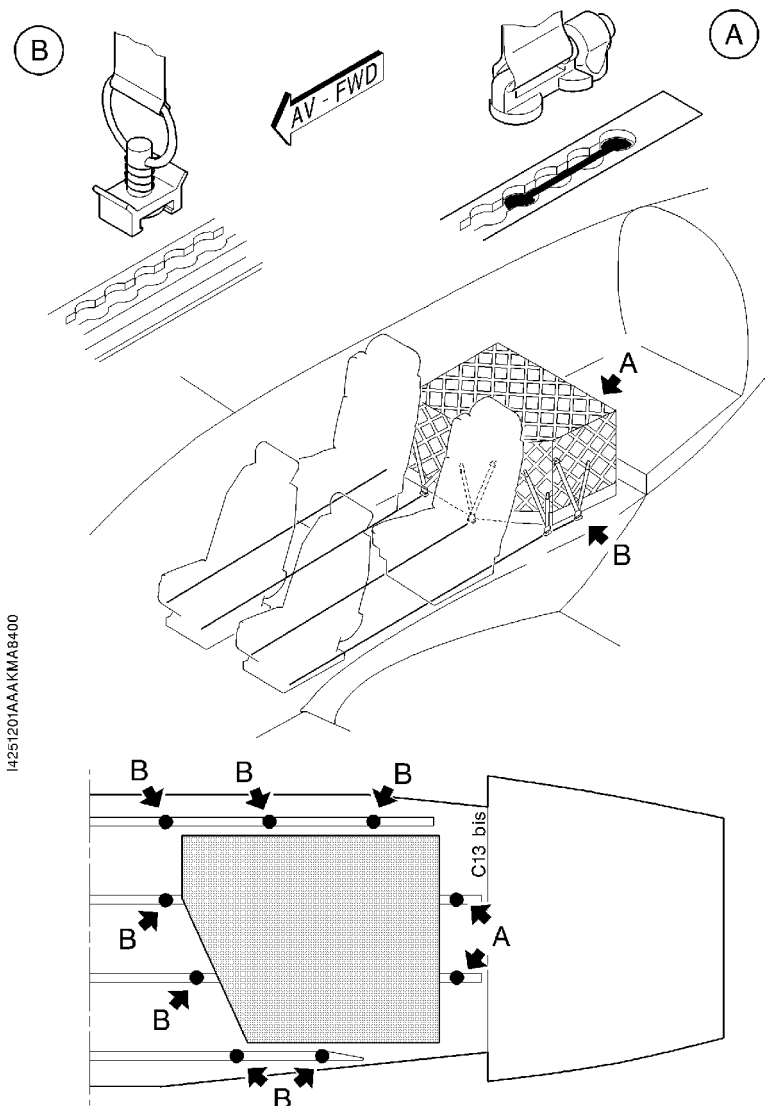

Figure 7.2.1B - Cabin arrangement
4-seat accommodation with small securing net

Wings

The wings are monocoque, bi-spar structures. Main spars of each wing are linked to the fuselage by two integral attach fittings. Each wing contains a main landing gear well and sealed casings forming the fuel tank. The wing leading edge is equipped with a deicing system.

Each wing extremity is equipped with a winglet.

Ailerons, spoilers and roll trim tab

The ailerons located on external trailing edge of each wing are hinged on two attach fittings fixed on the rear spar. They allow airplane lateral control and are controlled mechanically through control wheel rotation.

The spoilers located in front of flaps, on top skin side, are mechanically linked to the ailerons.

Trim tab attached on the trailing edge of left side aileron is electrically activated by a trim switch, through an actuator.

Wing flaps - see figure 7.2.2

The wing flaps are large span slotted flaps with a single rotation point. They are activated by actuating rod-controlled screw jacks linked to an electric motor located under the floor, inside the fuselage.

A preselection control located on the right side of pedestal console allows the pilot to select one of the three positions (UP - TO - LDG). For each control position, a deflection angle is defined (0°, 10°, 34°).

A monitoring device interrupts flaps movement as soon as a deflection dissymmetry is detected.

Empennages

Empennages are composite structures. The horizontal empennage consists of a horizontal stabilizer (PHF), control surfaces and elevator trim tabs ; the vertical empennage consists of a vertical stabilizer, the rudder and the rudder trim tab. The empennage leading edge is equipped with a deicing system.

- 1) Geared motor
- 2) Internal actuator
- 3) Intermediate bearings
- 4) Wing flap
- 5) External actuator
- 6) Rods
- 7) Control selector

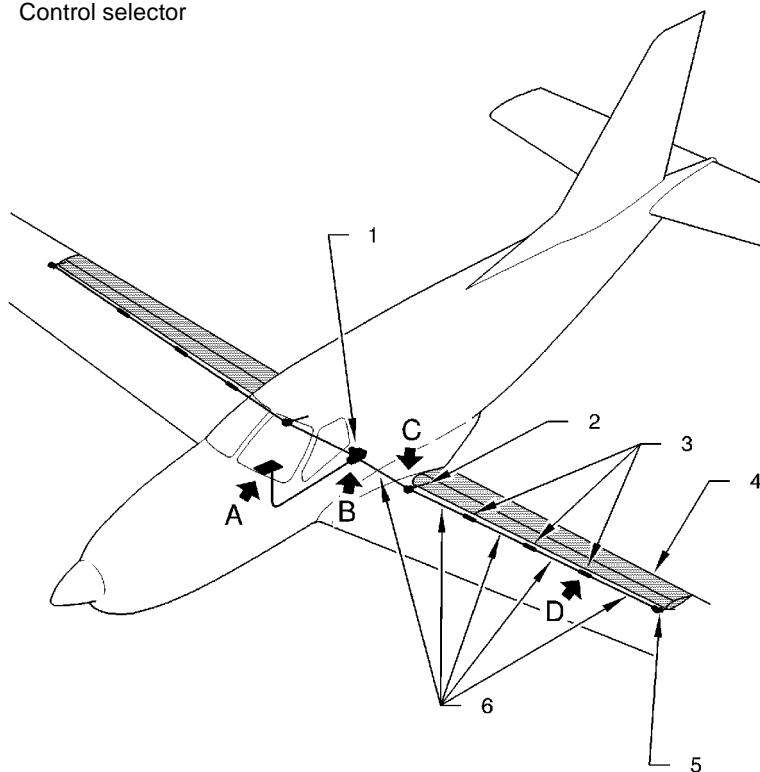

14275000/AAAAA/8003

Figure 7.2.2 (1/2) - Wing flaps

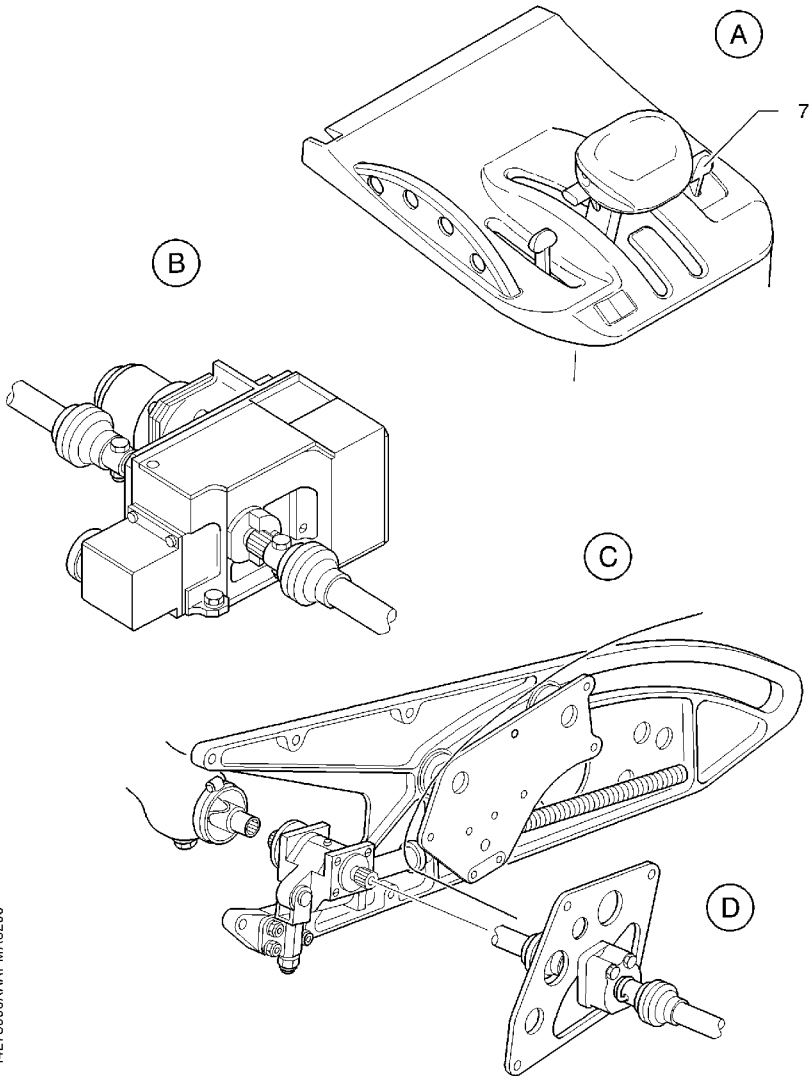

14275000AAAPMA8200

Figure 7.2.2 (2/2) - Wing flaps

Intentionally left blank

7.3 - Accomodations

Instrument panel

The instrument panel contains instruments and controls necessary for flight monitoring. The typical instrument panel consists of all standard equipment, as well as additional optional equipment.

Upper panel - see figure 7.3.2

The upper panel located at the top part of the windshield, contains electrical generation control panels, engine starting, electrical systems, AP/TRIMS switch, ELT remote control switch and the FUEL control panel.

Rearwards of upper panel, the central part of cockpit overhead panel provides loud-speakers and cockpit floodlights.

Instrument panel - see figure 7.3.1

The instrument panel consists of the integrated flight deck composed of three screens [two primary flight displays (PFD) and one multi-function display (MFD)] - refer to the GARMIN Pilot's Guide for detailed description. Apart from the GARMIN flight deck system, equipment listed below complete the instrument panel.

- Left area instrument panel includes - see figure 7.3.3 :
 - . on top : MD302, MASTER CAUTION and MASTER WARNING,
 - . on the left : DISPLAY BACKUP push-button, A/C CONTROL and SEATS HTRS MASTER (Post-MOD70-0588-25) panels
 - . at bottom : deicing controls and indicators, MICRO/MASK switch, hourmeter (Post-MOD70-0533-31A), landing gear control panel, parking brake control and left station control wheel.
- Central area instrument panel includes - see figure 7.3.4 :
 - . on top : surmounted by the stand-by compass, AFCS control unit, BARO knobs and the LVL push-button
 - . at bottom : touchscreen controllers and PRESSURIZATION panel.
- Right area instrument panel includes - see figures 7.3.5 and 7.3.5A :
 - . on top : locations for optional equipment,
 - . on the right: DISPLAY BACKUP push-button
 - . at bottom : alternate static source selector and the right station control wheel.
- Emergency air control is located under the right area instrument panel.

>> *Before digital hourmeter installation (Pre-MOD70-0533-31A)*

An hourmeter is located above circuit breakers panel.

>> *All*

An adjustable air outlet is located on both sides of instrument panel lower part.

Reception-micro jacks are located inside the recess under the arm-rest on both lateral sides of the cockpit, on R.H. side of intermediate R.H. passenger's seat and on the arm-rest of rear R.H. passenger's seat.

Pedestal console - see figure 7.3.6

The pedestal console, under the touchscreen controllers, comprises flaps controls, pitch trim tab control wheel, aileron trim switch, engine controls and fuel tank selector.

Circuit breakers panel - see figures 7.3.7 and 7.8.4

Circuit breakers for all electrical equipment supplied by bus bars are located on a separate panel installed on the right side of cockpit.

General alarms warning lights and CAS messages

WARNING, **CAUTION** and **ADVISORY** messages appear on the MFD CAS window to alert crew about monitored systems discrepancies. As a message appears, a chime is heard. Refer to the GARMIN Pilot's Guide to know all possible CAS messages.

A **MASTER WARNING** red flashing indicator and a **MASTER CAUTION** amber indicator located on instrument panel - see figure 7.3.8, in front of the pilot, illuminate as soon as one or several messages of same color light on.

To cancel and reset a general alarm, press on the red or amber indicator. A pressure on the red indicator also stops red message associated chimes.

Aural warnings - see figure 7.3.2

The aural warnings are intended to alert the pilot during some configurations. The aural signals are heard through the loud-speakers installed in cockpit overhead panel and through the pilot's and R.H. station headsets.

The aural warnings consist of :

- the GARMIN flight deck system (GIA and GMA),
- the loud-speaker.

The system uses :

- the stall warning system,

Pilot's Operating Handbook

- the airspeed indicator,
- the landing gear control unit,
- the flap geared motor,
- the idle position sensor.

Aural warning alerts

According to the airplane configuration, different aural warning alerts sound :

- gear up and idle \longrightarrow landing gear / landing gear
- gear up and extended flaps \longrightarrow landing gear / landing gear
- stall \longrightarrow stall / stall
- gear up, idle and stall \longrightarrow stall / landing gear
- gear up, extended flaps and stall \longrightarrow stall / landing gear
- IAS > 269 \pm 3 KIAS \longrightarrow overspeed / overspeed

Refer to the GARMIN Pilot's Guide for description of the other aural warning alerts.

Cockpit overhead panel - see figure 7.3.2

This panel includes following elements :

- the loud-speaker of GMA,
- the TEST push-button,
- the emergency lighting rheostat.

It is attached to the cabin upper part between frames C6 and C7.

The emergency lighting rheostat is electrically supplied by BATT BUS bar and protected by PANEL EMER circuit breaker.

The TEST push-button allows to test :

- the autopilot control panel backlighting,
- the MASTER WARNING and MASTER CAUTION indicators,
- the deicing panel led,
- the stick shaker system,
- the fire detection system, if installed,
- the stall aural warning alert,
- the DISPLAY BACKUP push-buttons backlighting,
- the LVL push-button.

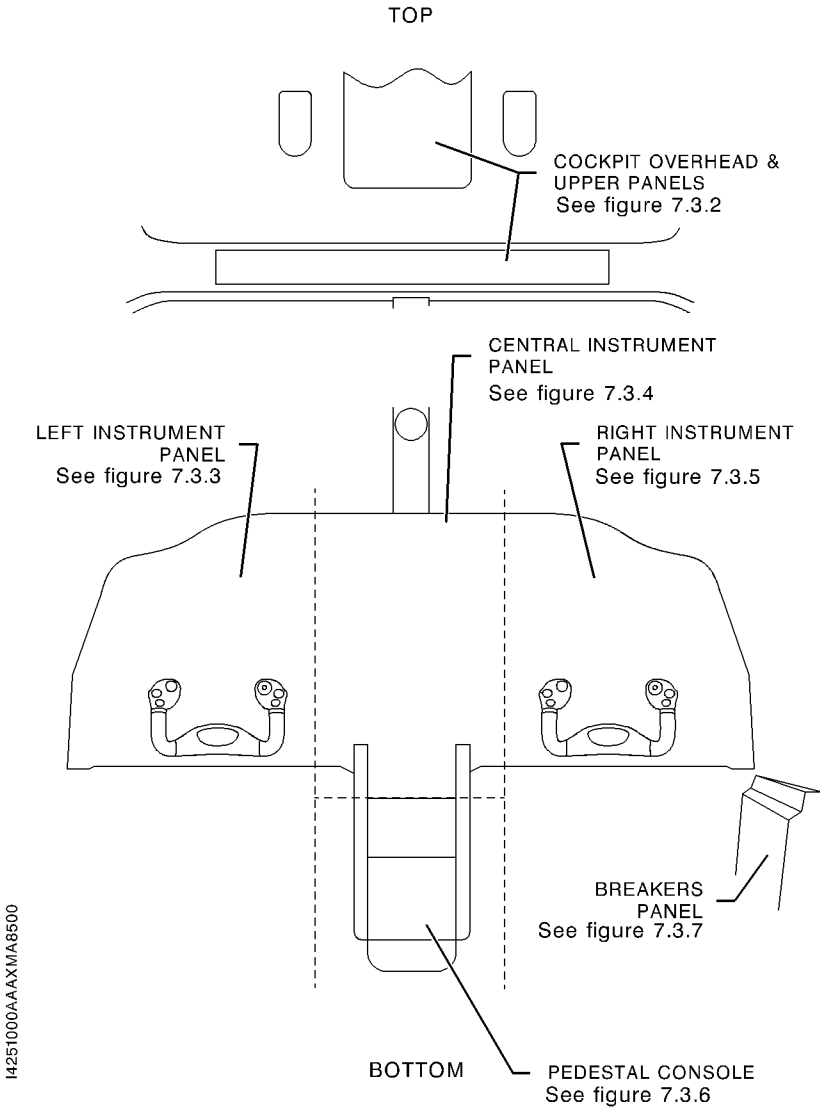

Figure 7.3.1 - Instrument panel assembly
(Typical arrangement)

Intentionally left blank

- 1) L.H. instrument panel emergency lighting
- 2) Loud-speaker of GMA
- 3) R.H. instrument panel emergency lighting
- 4) Instrument panel emergency lighting switches (rheostats)
- 5) R.H. cockpit floodlight
- 6) ELT remote control switch
- 7) AP/TRIMS switch
- 8) FUEL control panel - see figure 7.7.3
- 9) ENGINE START switches - see figure 7.6.4
- 10) ELECTRIC POWER switches - see figure 7.8.5
- 11) INT LIGHTS internal lighting switches - see figure 7.8.7
- 12) EXT LIGHTS external lighting switches - see figure 7.8.6
- 13) L.H. cockpit floodlight
- 14) TEST push-button

Figure 7.3.2 (1/2) - Upper panel and cockpit overhead panel

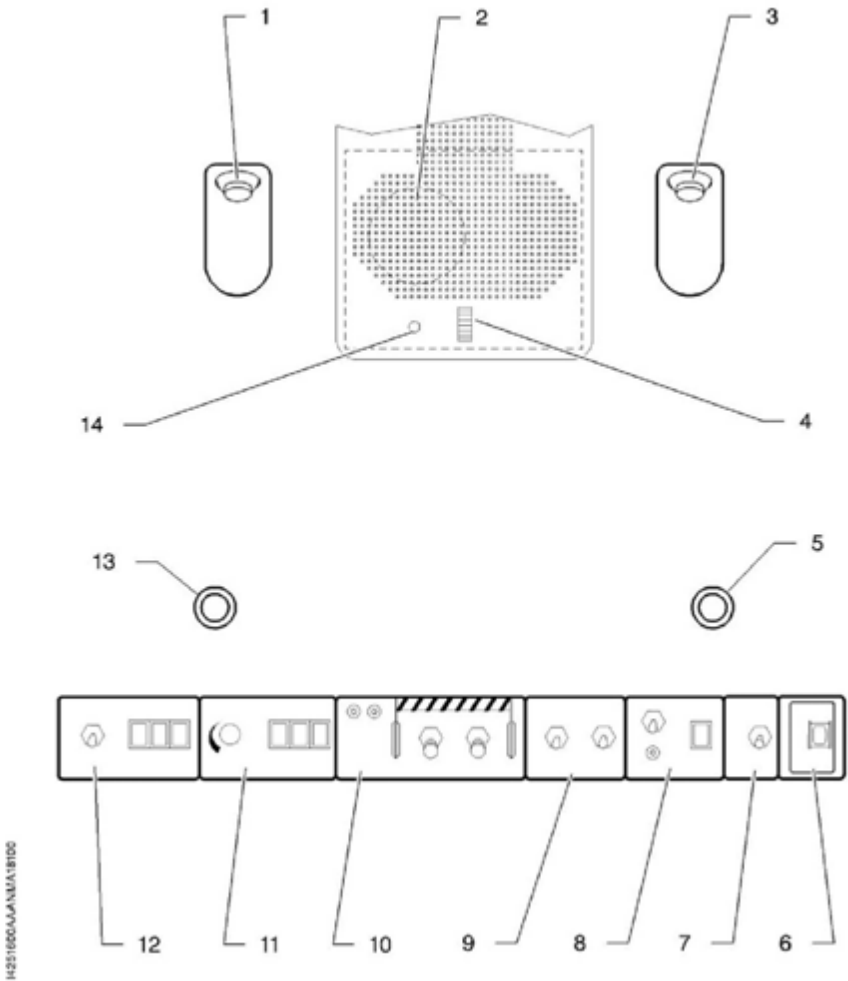

Figure 7.3.2 (2/2) - Upper panel and cockpit overhead panel

- 1) DISPLAY BACKUP, A/C CONTROL and SEATS HTRS MASTER (Post-MOD70-0588-25) panels - see figure 7.9.3
 - 2) General alarm red and amber indicators
 - 3) PFD 1
 - 4) MD302
 - 5) Landing gear configuration and control panel - see figure 7.5.1
 - 6) Parking brake control - see figure 7.5.6
 - 7) Left station control wheel tube
 - 8) Deicing control and check panel - see figure 7.13.1
 - 9) L.H. station rudder pedals adjusting handle
 - 10) Left station reception-micro jacks
 - 11) Pitch & Yaw trim setting management
 - 12) Push To Talk button (PTT)
 - 13) AP / TRIM DISC push-button
 - 14) CWS
 - 15) Paper clip
 - 16) Chronometer management
 - 17) Transponder Ident sequence
 - 18) Stormscope clear
 - 19) COM 2 (Stand-by / active)
 - 20) Flight conditions and instruction placard
 - 21) Adjustable air outlet
 - 22) Circuit breaker panel lighting switch
 - 23) MICRO / MASK switch - see figure 7.10.1
- >> After digital hourmeter installation (Post-MOD70-0533-31A)
- 24) Hourmeter
- >> After servicing plugs installation (Post-MOD70-0531-25)
- 25) USB servicing plug

Figure 7.3.3 (1/2) - Left instrument panel



Figure 7.3.3 (2/2) - Left instrument panel
(Typical arrangement)

- 1) Stand-by compass
- 2) BARO knobs
- 3) Registration
- 4) AFCS control unit
- 5) Touchscreen controllers
- 6) PRESSURIZATION panel - see figure 7.9.1
- 7) MFD
- 8) Micro LDR
- 9) LVL push-button

Figure 7.3.4 (1/2) - Central instrument panel



Figure 7.3.4 (2/2) - Central instrument panel
(Typical arrangement)

>> *Up to S/N 1159*

- 1) PFD 2
- 2) DISPLAY BACKUP push-button
- 3) Right station control wheel tube
- 4) Crew music
- 5) Adjustable air outlet
- 6) Right station reception-micro jacks
- 7) Hourmeter
- 8) R. H. station rudder pedals adjusting handle
- 9) Circuit breakers panel postlight
- 10) Cigar lighter and two USB servicing plugs
- 11) Cabin emergency air control (EMERGENCY RAM AIR control knob)
- 12) Static source selector
- 13) COM 2 (Stand-by / active)
- 14) Stormscope clear
- 15) Transponder Ident sequence
- 16) Chronometer management
- 17) Paper clip
- 18) CWS
- 19) AP / TRIM DISC push-button
- 20) Push To Talk button (PTT)
- 21) Pitch & Yaw trim setting management

Figure 7.3.5 (1/2) - Right instrument panel



Figure 7.3.5 (2/2) - Right instrument panel
(Typical arrangement) - Up to S/N1159

>> From S/N 1160

- 1) PFD 2
- 2) DISPLAY BACKUP push-button
- 3) Right station control wheel tube
- 4) Crew music
- 5) Adjustable air outlet
- 6) Right station reception-micro jacks
- 7) R. H. station rudder pedals adjusting handle
- 8) Circuit breakers panel postlight
- 9) USB servicing plugs
- 10) Cabin emergency air control (EMERGENCY RAM AIR control knob)
- 11) Static source selector
- 12) COM 2 (Stand-by / active)
- 13) Stormscope clear
- 14) Transponder Ident sequence
- 15) Chronometer management
- 16) Paper clip
- 17) CWS
- 18) AP / TRIM DISC push-button
- 19) Push To Talk button (PTT)
- 20) Pitch & Yaw trim setting management

Figure 7.3.5A (1/2) - Right instrument panel

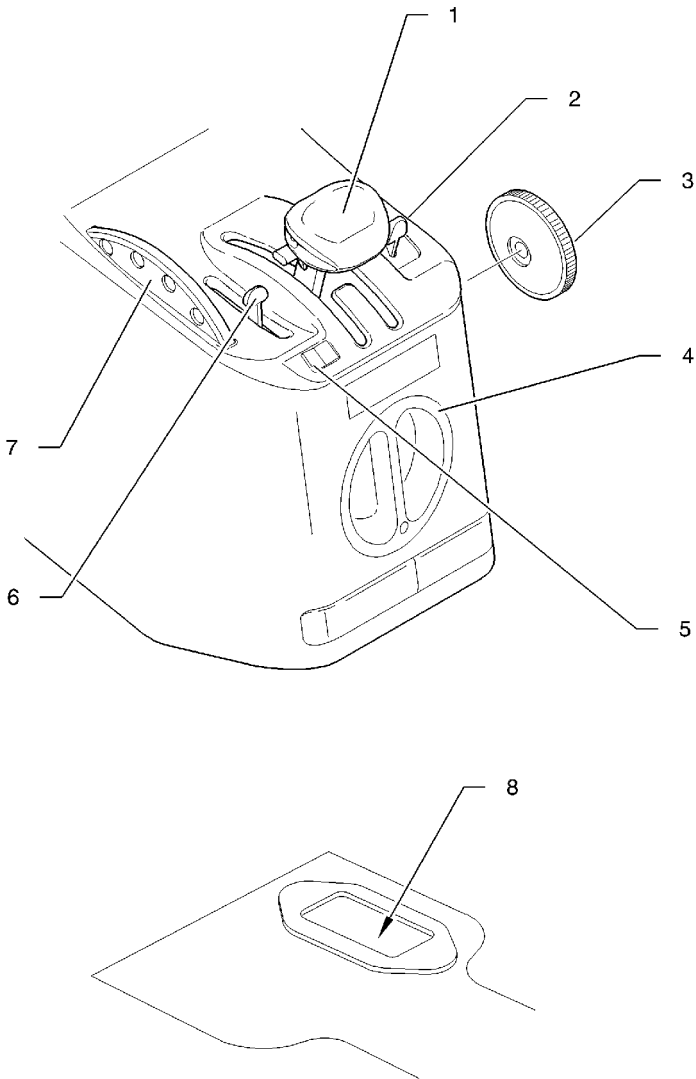

Figure 7.3.5A (2/2) - Right instrument panel
(Typical arrangement) - From S/N 1160

■ >> All

- 1) THROTTLE
- 2) FLAPS lever
- 3) THROTTLE friction adjustment
- 4) Manual FUEL TANK SELECTOR - see figure 7.7.2
- 5) Roll trim tab control
- 6) MAN OVRD emergency fuel regulation lever
- 7) Pitch trim tab control
- 8) Lock for access door to landing gear emergency pump - see figure 7.5.2

Figure 7.3.6 (1/2) - Pedestal console



I4274004AAACMA8200

Figure 7.3.6 (2/2) - Pedestal console
(Typical arrangement)

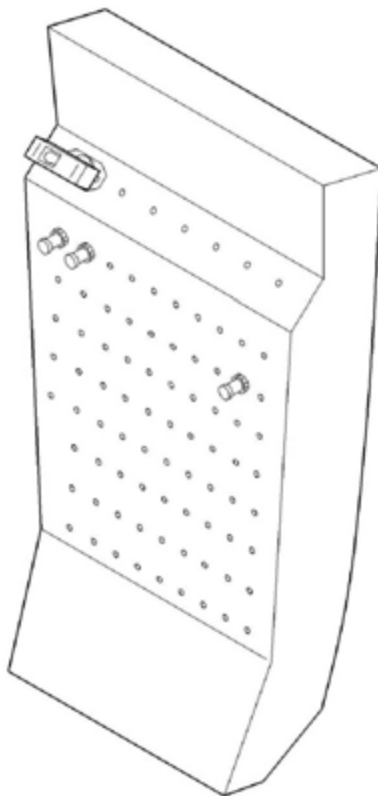
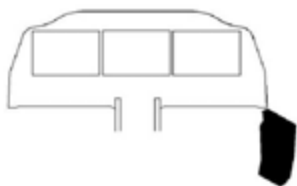

1425004AAA/P/M/0200

Figure 7.3.7 - Circuit breakers panel



Figure 7.3.8 - General alarms warning lights

Doors, windows and emergency exit

Cabin access door - see figure 7.3.9

The cabin one-piece access door, located on the left side of fuselage aft of the wings, opens outside. The retractable stairs and hand rail make boarding easier.

To open the door from outside the airplane (make sure the door is not locked), press on front end of the handle embedded in door (this pressure disengages the handle from its recess), then turn the handle upwards. Raise the door helping it to open. Two compensation actuators bring and maintain the door at its maximum opening position.

After door opening, tilt stairs downwards. Stairs down movement is damped by means of two gas struts and leads the hand rail to extend.

▲ CAUTION ▲

Retract stairs before closing access door and make sure door deflection area is clear.



To retract stairs, press on locking pin located on stairs front string board (see detail 1), raise retractable handle - see detail 2 and pull stairs inside cabin. While stairs are retracted, the hand rail folds up.

To close the door from inside the airplane, press on knob inside cabin forward of the door. The door driven by a geared motor tilts downwards up to a position near the complete closing. Pull the door until it aligns with fuselage and lock it by moving inside handle downwards. Check that all latch pins and hooks are correctly engaged (visible green marks).

DOOR lights on as long as cabin access door and pilot access door, if installed, are not correctly locked.

▲ CAUTION ▲

Before opening access door, make sure door deflection area is clear.



To open door from inside the cabin, unlock the handle by pressing on knob located on its left side, pull the handle toward inside and move it upwards. Open the door by pushing it upwards.

After door opening, tilt stairs downwards which leads the hand rail to extend.

▲ CAUTION ▲

Retract stairs before closing access door and make sure door deflection area is clear.



To retract stairs from outside the airplane, raise stairs by pushing them upwards from the lower part and fold them inside cabin. While stairs are retracted, the hand rail folds up.

To close the door from outside the airplane, press on knob on outside fuselage at the right side of the door. The door driven by a geared motor tilts downwards up to a position near the complete closing. Push the door until it aligns with fuselage and lock it by moving outside handle downwards, then fold handle in its recess.

Check that all latch pins and hooks are correctly engaged, with green marks visible.

In case of geared motor failure, the door can be manually tilted downwards by pulling sufficiently to override action of compensating struts.

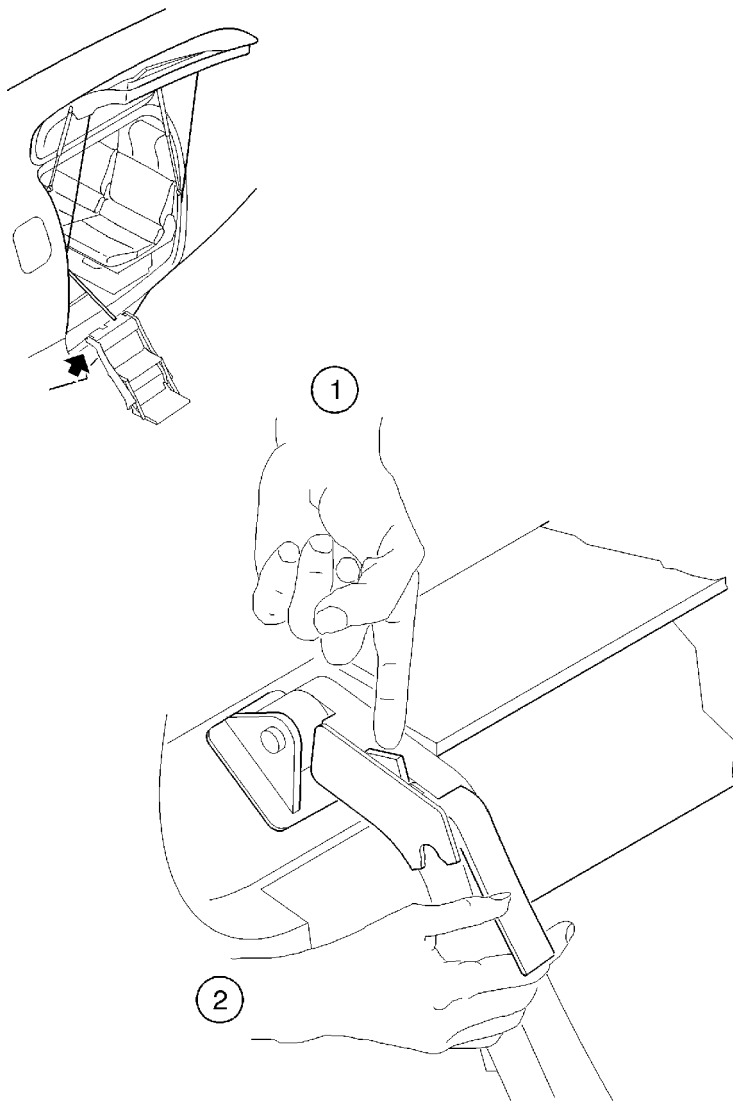

14623000AAA FMA8001

Figure 7.3.9 - Cabin access door

Cockpit access door - see figure 7.3.9A

The cockpit access door, so-called pilot door, if installed located on the left side of fuselage forward of the wings, opens outside. Retractable footstep makes boarding easier.

▲ WARNING ▲

As the pilot door is located in a dangerous area, wait for complete engine stop before operating this door.



To open the door from outside the airplane (make sure the door is not locked), press on front end of the handle embedded in door (this pressure disengages the handle from its recess), then turn the handle downwards. Pull the door helping it to open until it reaches its maximum opening position.

After door opening, tilt and unfold footstep.

▲ CAUTION ▲

Retract footstep before closing access door.



Fold and tilt footstep upwards.

To close the door from inside the airplane, pull the door until it aligns with fuselage and lock it by moving inside handle downwards. Check that each latch is correctly engaged in its recess, with green marks visible.

DOOR lights on as long as cabin access door and pilot access door, if installed, are not correctly locked.

To open door from inside the cockpit, unlock the handle by pressing on knob located on its right side, pull the handle inwards and move it upwards. Open the door helping it to open until it reaches its maximum opening position.

After door opening, tilt and unfold footstep.

▲ CAUTION ▲

Retract footstep before closing access door.



Fold and tilt footstep upwards.

To close the door from outside the airplane, push the door until it aligns with fuselage and lock it by moving outside handle upwards, then fold handle in its recess.

FWD compartment door

The FWD compartment door is located on the airplane left side between the firewall and the front pressure bulkhead. It is hinged at the top. It is maintained in the up position by a compensation rod. Two interlocking-type latches ensure its closing and it is equipped with a lock (same key as for the access door and the pilot door, if installed). When the door is closed, latches are flush with the fuselage profile.

CARGO DOOR lights on as long as FWD compartment door is not locked.

Windows

Windows do not open. The windshield consists of two parts electrically deiced.

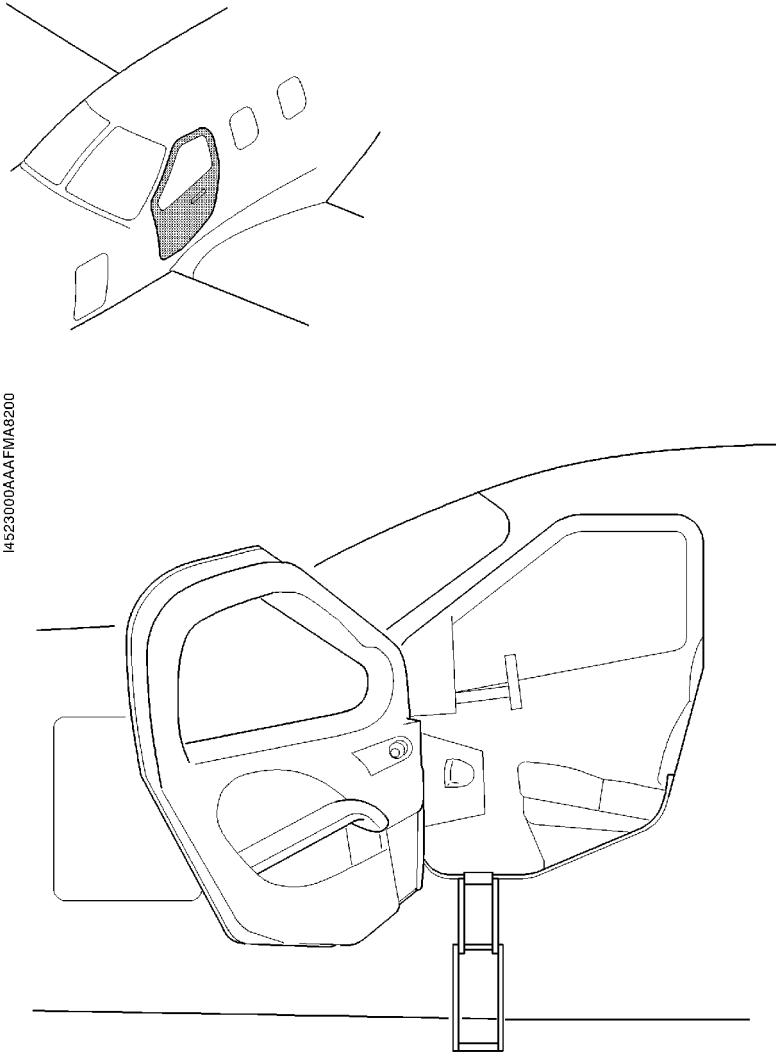

Figure 7.3.9A - Cockpit access door (pilot door)

Emergency exit - see figure 7.3.10

The emergency exit is installed on the right side of the fuselage and opens towards the inside. It is equipped with two handles, one inside and the other outside, each located on the upper frame.

When the airplane is parked, the closing system may be locked by a safety pin provided with a flag marker. The handle is then inoperable.

▲ WARNING ▲

Taxiing and flying with thief-proof safety pin installed is forbidden.



To open the emergency exit, pull one of the two handles and tilt the emergency exit from top to bottom towards inside of airplane.

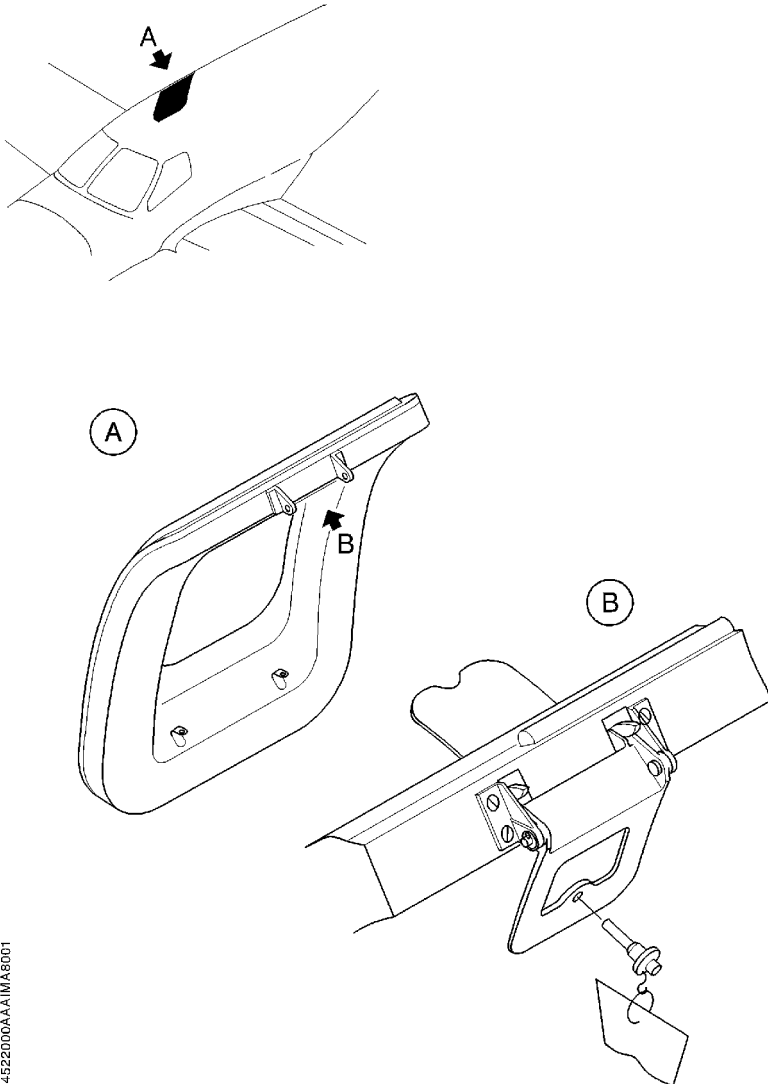

14522000AA-A1MIA8001

Figure 7.3.10 - Emergency exit

Seats, belts and harnesses

>> *Airplane with seat heaters (Post-MOD70-0588-25)*

Heated seats - see figure 7.3.11

Cockpit and cabin seats are equipped with a heating system for the comfort of pilot and passengers.

The system consists of :

- One heating element in the cushion and one heating element in the backrest of each seat,
- The SEATS HTRS MASTER switch located on the instrument panel,
- HI/OFF/LOW three-position switch located on each cockpit and cabin seat,
- The seat heaters control box and relays located under the floor panel.

Each seat is equipped with a power supply wire with a connector. A clip attaches the connector to the seat to prevent damage during seat operation or seat storage.

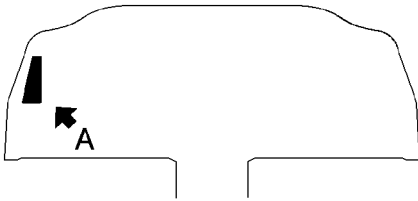

- 1) SEATS HTRS MASTER switch
- 2) Backrest surface heating
- 3) Seat surface heating
- 4) HI/OFF/LOW three position switch
- 5) Tactile marks

14251204A AAA MA18000

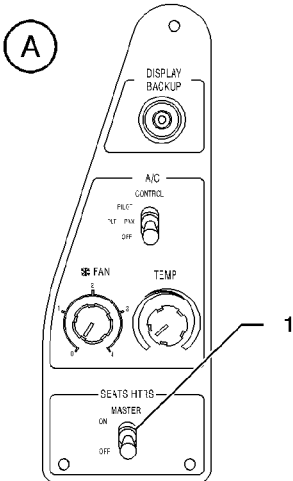

(B)

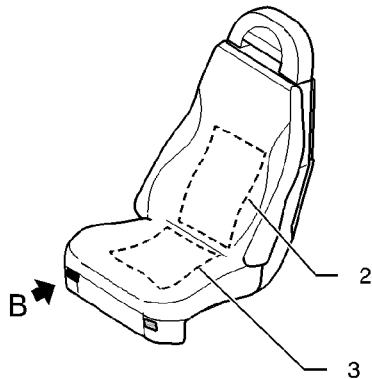
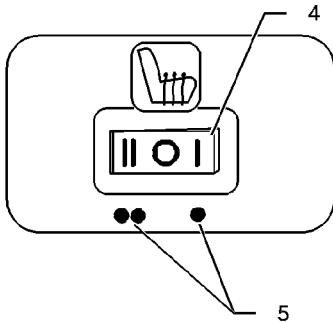

 ALTERNATE LOCATION

Figure 7.3.11 - Heated seat

The seats heating is only available when the airplane is connected to a GPU or when the main generator is supplying power.

The system does not operate if GENERATOR selector is set to ST-BY.

The SEATS HTRS MASTER switch allows the pilot to enable or not the electrical supply of all seats heaters.

Each seat is then individually controlled by the HI/OFF/LOW switch :

● NOTE ●

Two tactile marks located under the HI / OFF / LOW switch enables to determine which position is selected.

●

- OFF position is obtained when the switch is in the central position. In this position the seat does not heat.
- HI position is obtained by positioning the switch to the right. In this position the seat heats at its maximum capacity.
- LOW position is obtained by positioning the switch to the left. In this position the seat heats less than HI position.

● NOTE ●

In HI position, the heating sensation comes up after approximately 3 minutes.

●

To avoid overheating, each seat is equipped with thermal sensors which remove power supply in case of overtemperature detection.

Precaution of use of the seats heaters system :

- Do not place any sharp or heavy objects on the seat, as the seat heater could otherwise be damaged.
- Persons with an impaired sensitivity to heat should only operate the seat heater at low level.
- Do not place any heat insulating objects, such as blankets or coats, on the seat when the seat heater is switched on.
- The seat heater can be damaged by fluids spilt on the seat.
- Never switch the seat heater on when it is wet.

■ >> *All*

Cockpit seats - see figure 7.3.12

L.H. and R.H. front seats are mounted on rails attached to the structure. Longitudinal position, height and back-rest tilting of each seat can be adjusted and the arm-rest is hinged.

Pull up the handle located forward for longitudinal setting.

The seat height is adjusted by pulling up side forward handle while relieving the seat from the body weight.

The seat back angle is adjusted by pulling up side rearward handle.

Passenger seats - see figures 7.3.12 and 7.3.12A

>> *With 6-seat accommodation*

The accommodation consists of :

- two individual seats, installed back to the flight direction, mounted on the same rails as the front seats.
The seat back angle is adjusted by pulling up side handle.
- two rear seats arranged as a bench, mounted on the same rails as the front seats.
The seat back-rests tilt forward by pulling up the handle located forward on L.H. side of each seat which may tilt forwards by pulling up a rear handle to ease baggage loading in baggage compartment.
For longitudinal setting pull up the handle located forward, on R.H. side.

>> *With 4-seat accommodation*

The accommodation consists of :

- two individual seats, installed facing flight direction, mounted on the same rails as the front seats.
The seat back angle is adjusted by pulling up side handle.

Many accommodations are possible. They are described hereafter

ONLY zone **B** and zone **C** can be modified for seat configurations

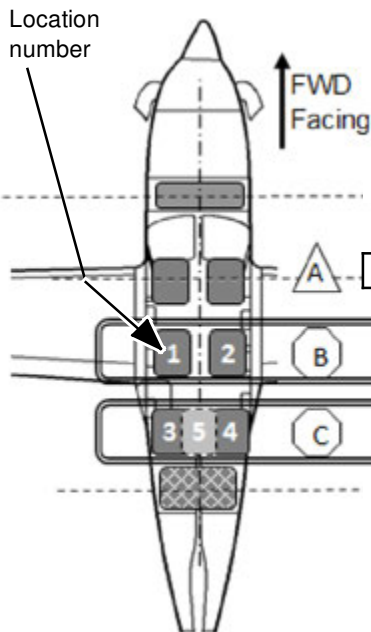

For all configurations, verify that your luggages are stowed and attached in the appropriate areas

Fwd baggage zone

Pilot zone: No modification allowed

MID Seat Zone = Possibility of seat configuration

REAR Seat Zone = Possibility of seat configuration if no net installations

Cargo zone

If installed, cabinets can be removed or added by Service Center

For the MID Seat zone **B**

ONLY the Middle Seats can be installed in MID Seat Zone.
This zone accepts Fwd and Aft Facing Mid Seat when rear seats are installed

The zone **B** accepts zero or 1 or 2 seats.

(The zone **B** is not a luggage area).

Location number	FWD Facing	AFT Facing	Number of seat can be installed
1	YES	YES	1 or 0
2	YES	YES	1 or 0

For the REAR Seat zone **C**

ONLY the Rear Seat can be installed in Rear Seat Zone.

The Zone **C** accepts zero or 1 or 2 seats.

Location number	FWD Facing	Number of seat can be installed
3	YES	1 or 0
4	YES	1 or 0
5 *(1)	YES *(1)	1 or 0 *(1)

*(1) Centered on the fuselage axis

Here are all the configurations possibilities

Configuration name	Location number				
	1	2	3	4	5
C1	X	X	X	X	
C2 (2)	X	X			X
C3	X	X		X	
C4 (1)	X	X			
C5	X	X	X		
C6	X		X	X	
C7	X		X		
C8	X			X	
C9 (2)	X				X
C10 (1)	X				
C11		X	X	X	
C12 (2)		X			X
C13		X	X		
C14		X		X	
C15 (1)		X			
C16			X	X	
C17			X		
C18				X	
C19 (2)					X
C20 (1)					
	Zone B		Zone C		

(1) This configuration accepts small net or large net

(2) With seats heaters system (MOD70-0588-25)

In this position, the seats heaters system cannot be connected to the rear seat.

Each cross indicates that you have a seat at the correspondent location number.

Belts and harnesses - see figure 7.3.13

▲ WARNING ▲

Incorrect closure of the safety belt may introduce a risk. Make sure it is tightened when buckled. To be most efficient, the belt must not be twisted. Check that there is no constraint when operated. After a serious accident, replace all belts.



Each cockpit seat is equipped with a four-point restraint system consisting of an adjustable lap belt and a dual-strap inertia reel-type shoulder harness with airbags, if installed.

Each passenger seat is equipped with a three-point restraint system consisting of an adjustable lap belt and an inertia reel-type shoulder harness.

Airbags, if installed, are inflated by two inflators located under the backrest fairing, which are activated by an accelerometer fixed under the floor panel in front of the seat.

Baggage compartments

>> *With 6-seat accommodation*

There are two baggage compartments :

- An AFT compartment located in the pressurized cabin between rear passenger seats and rear pressure bulkhead.
- A FWD compartment (non-pressurized) located between firewall and fwd pressure bulkhead.

The AFT compartment is accessible through the cabin by tilting forward the L.H. rear seat and / or L.H. or R.H. rear seat back-rests. Rings fitted with lashing straps are provided for securing parcels and baggage on compartment floor.

The FWD compartment is accessible by opening the external door located on the left side of the airplane.

These locations are designed for the carrying of low density loads ; loading and unloading must be carried out with caution to avoid any damage to airplane.

The cabin is separated from the baggage compartment by a partition net intended to protect the passengers from injuries that could be caused by improper tie-down of a content.

The partition net is mounted at frame C14 - see figure 7.2.1, it is secured at the bottom to 4 points of the floor and on the sides to 6 points of the structure.

Maximum loads allowable in the baggage compartments depend on airplane equipment, refer to section 6 Weight and balance.

▲ **WARNING** ▲

Any parcel or baggage must be stowed by straps.

It is the pilot's responsibility to check that all the parcels and baggage are properly secured in the cabin.

In case of transport of dangerous materials, respect the law concerning transport of dangerous materials and any other applicable regulation.



>> *With 4-seat accommodation*

Two cargo nets are available for the pilot to safely secure and transport baggage :

- the small cargo net is attached through nine anchoring points on seat rails, between frame C11 and frame C13bis - see figure 7.2.1B.

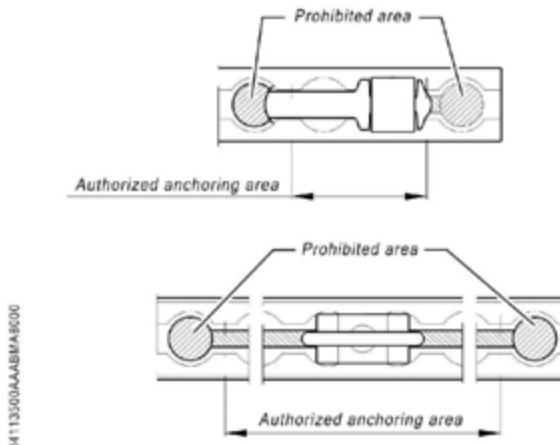

- the large cargo net is attached through seven anchoring points on seat rails, between frame C11 and frame C13bis and six anchoring points on fuselage sides, at frame C14 - see figure 7.2.1A.

● **NOTE** ●

Original partition net must be disconnected from side walls and placed on the floor.



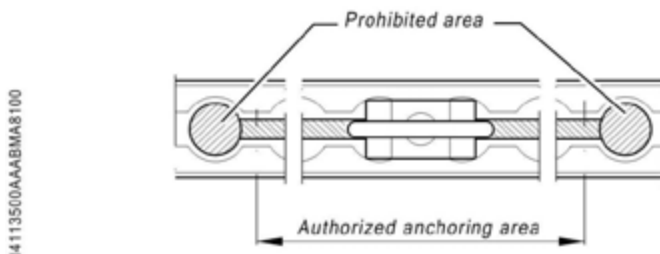

Authorized anchoring points are identified with green self-adhesive labels affixed to the inside of the seat rail.

A placard indicates loading limits for each cargo net :

- for the small cargo net, it is affixed on frame C13bis,
- for the large cargo net, it is affixed on R.H. side upholstery panel, in the rear baggage compartment.

Maximum loads allowable in the baggage compartments depend on airplane equipment, refer to section 6 Weight and balance.

▲ WARNING ▲

Any parcel or baggage in cabin must be stowed by cargo net and straps.

It is the pilot's responsibility to check that all the parcels and baggage are properly secured.

In case of transport of dangerous materials, respect the law concerning transport of dangerous materials and any other applicable regulation.



Use of cargo nets

Net inspection

Before each use, visually inspect net for :

- webbing condition,
- seam condition of tensioning strap,
- metallic part condition.

Installation instructions

Tensioning straps must be installed so that they make a V with a minimum angle of 40° between both strands attached on the net. The net must be properly tight.

Damage acceptance criteria

If any damage is detected, such as :

- damage or absence of hook, buckle or stud on tensioning strap : strap must **mandatorily** be discarded and replaced,
- webbing frayed or cut on less than 30 % of its surface : reduce maximum load by 50 %,
- seam of vertical net tensioning straps damaged on less than 30 % of its length : reduce maximum load by 50 %,
- seam of tensioning straps attached on the rails damaged on less than 30 % of its length : reduce maximum load by 50 %,
- beyond 30% damage for above-mentioned cases, defective element must mandatorily be discarded and replaced,
- netting cut or torn on less than 3.9 in (100 mm) : still serviceable, no impact,
- netting cut or torn on more than 3.9 in (100 mm) : do not carry small objects which dimensions are smaller than 4.9 x 4.9 x 4.9 in (125 x 125 x 125 mm).

>> *With 6-seat accommodation*

- 1) Front passenger seat
- 2) L. H. pilot seat
- 3) R. H. intermediate passenger seat, back to flight direction
- 4) L. H. intermediate passenger seat, back to flight direction
- 5) R. H. rear passenger seat
- 6) L. H. rear passenger seat
- 7) Front seat(s) longitudinal shift control
- 8) Front seat(s) height control
- 9) Front seat(s) back-rest tilt control
- 10) Drawer for pilot's piddle pak, if installed
(front side : new bags, rear side : used bags)
- 11) Intermediate seat(s) back-rest tilt control
- 12) Rear bench seat(s) back-rest tilt control
- 13) Rear bench L.H. seat tilt control
- 14) Rear bench seat(s) adjustment control handle

● NOTE ●

To have access to the baggage compartment, pull forwards the back-rest of rear bench L.H. seat, then pull forwards control (Item 13) to tilt L.H. seat assembly forwards.
If necessary, pull forwards the back-rest of rear bench R.H. seat.

●

Figure 7.3.12 (1/2) - Seats

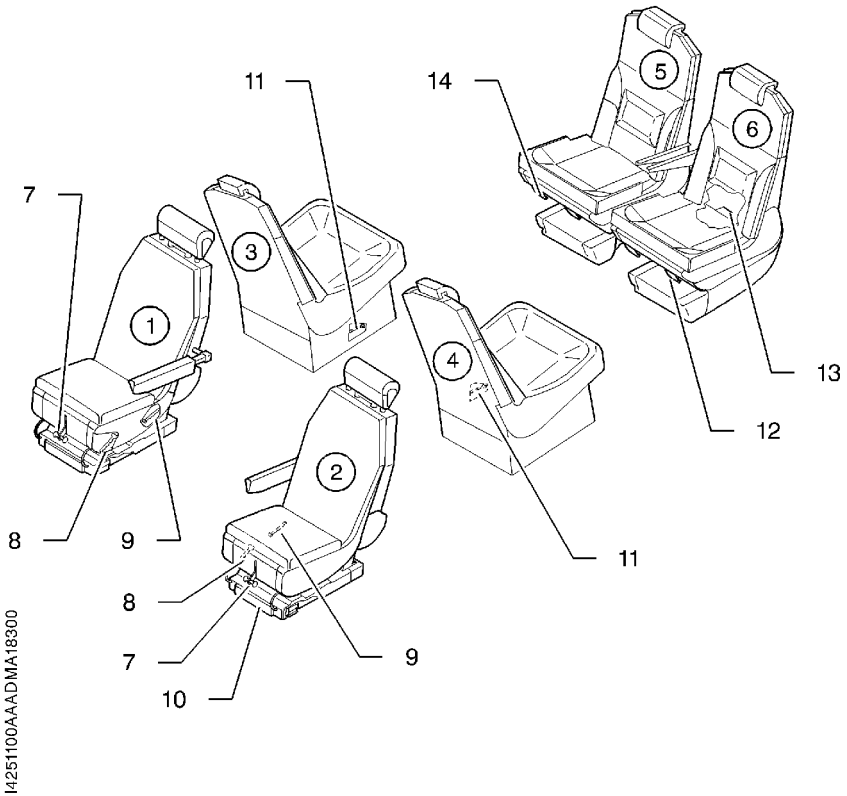
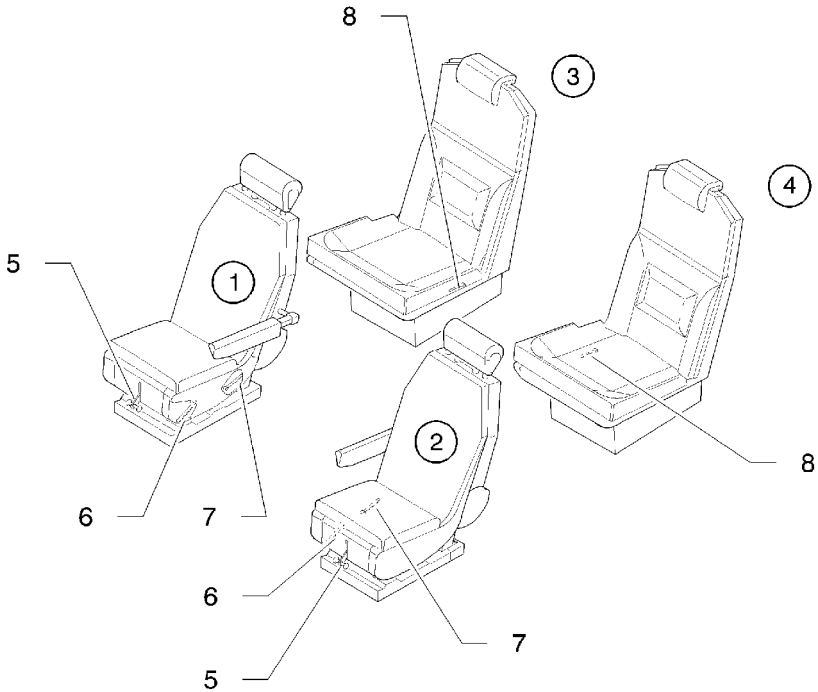

Figure 7.3.12 (2/2) - Seats

>> *With 4-seat accommodation*

- 1) Front passenger seat
- 2) L. H. pilot seat
- 3) R. H. intermediate passenger seat, facing flight direction
- 4) L. H. intermediate passenger seat, facing flight direction
- 5) Front seat(s) longitudinal shift control
- 6) Front seat(s) height control
- 7) Front seat(s) back-rest tilt control
- 8) Intermediate seat(s) back-rest tilt control

Figure 7.3.12A (1/2) - Seats



I4251100AAADMA18200

Figure 7.3.12A (2/2) - Seats

>> All

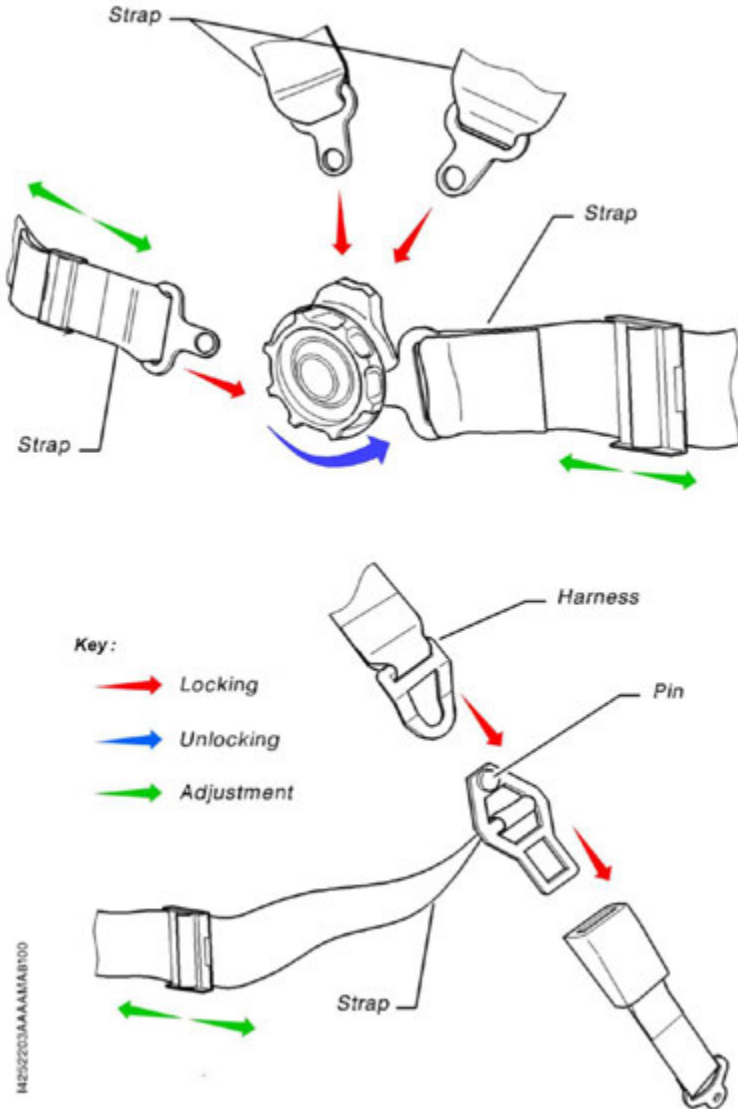

Figure 7.3.13 - Front and rear seat belts,with movable straps, and harnesses

7.4 - Flight controls

Flight controls consist of roll, pitch and rudder controls, as well as roll trim tab, pitch trim tab and rudder trim tab controls.

• NOTE •

During airplane parking, it is recommended to lock flight controls -
see figure 8.6.2

•

Roll - see figure 7.4.1

The roll control is activated by an assembly of rods and cables which links control wheels with the ailerons and the spoilers.

Aileron displacement is combined with that of spoilers, located at upper surface of each wing forward of flaps.

The spoiler rises from wing upper surface profile, when the aileron is deflected upwards and remains in wing profile, when the aileron is deflected downwards.

Control wheel movement is transmitted through rods to fuselage roll lever located under the floor. The movement is then transmitted through cables to the spoiler mechanism and from the spoiler mechanism to wing roll lever which activates the aileron through a rod.

A rudder / roll combination spring-type system induces roll deflection at the time of pedals movement and vice versa.

Roll trim - see figure 7.4.2

The roll trim is controlled by a trim tab attached at trailing edge of the L.H. aileron. The trim tab is connected through two links to an electric actuator located in the aileron. A trim switch located on pedestal controls the roll trim tab maneuver.

Roll trim tab electrical circuit is protected by the AIL TRIM breaker.

- 1) Pedestal assembly
- 2) Control wheels
- 3) Fuselage roll lever
- 4) Spoiler
- 5) Aileron
- 6) Aileron control in wing
- 7) Spoiler control

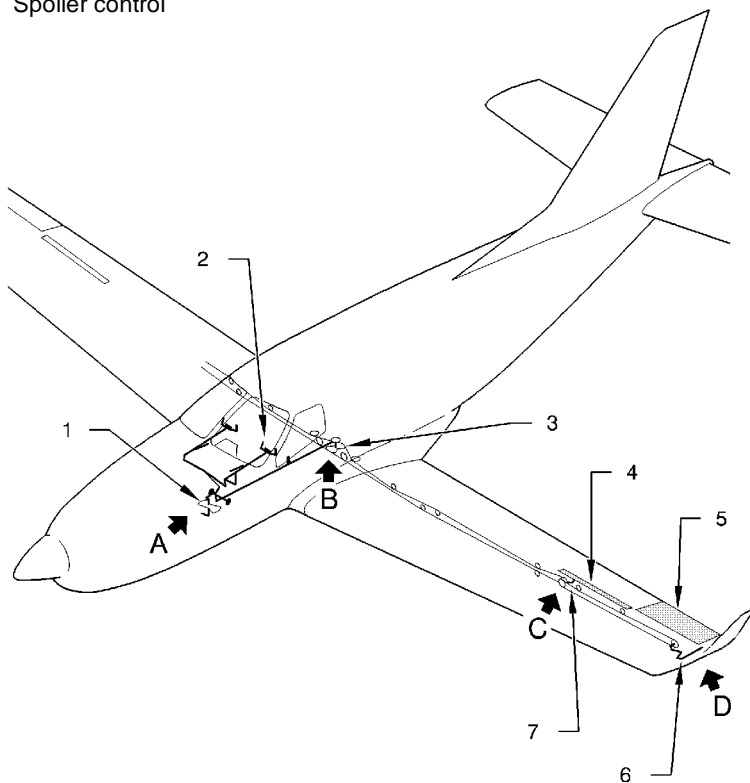

14271000AAAAMAB101

Figure 7.4.1 (1/2) - Roll

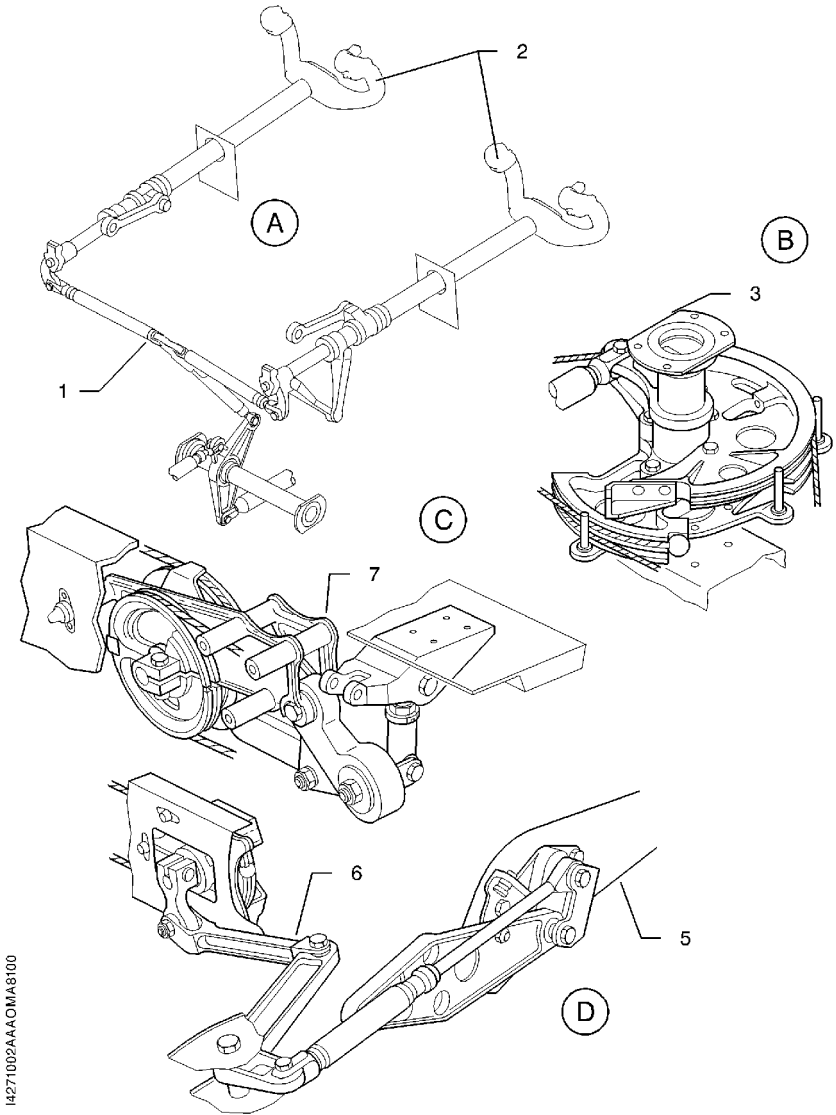

14271002AAACOMA8100

Figure 7.4.1 (2/2) - Roll

- 1) Roll trim tab
- 2) Aileron
- 3) Adjustable rods
- 4) Actuator
- 5) Trim tab control wiring
- 6) Trim switch on pedestal console

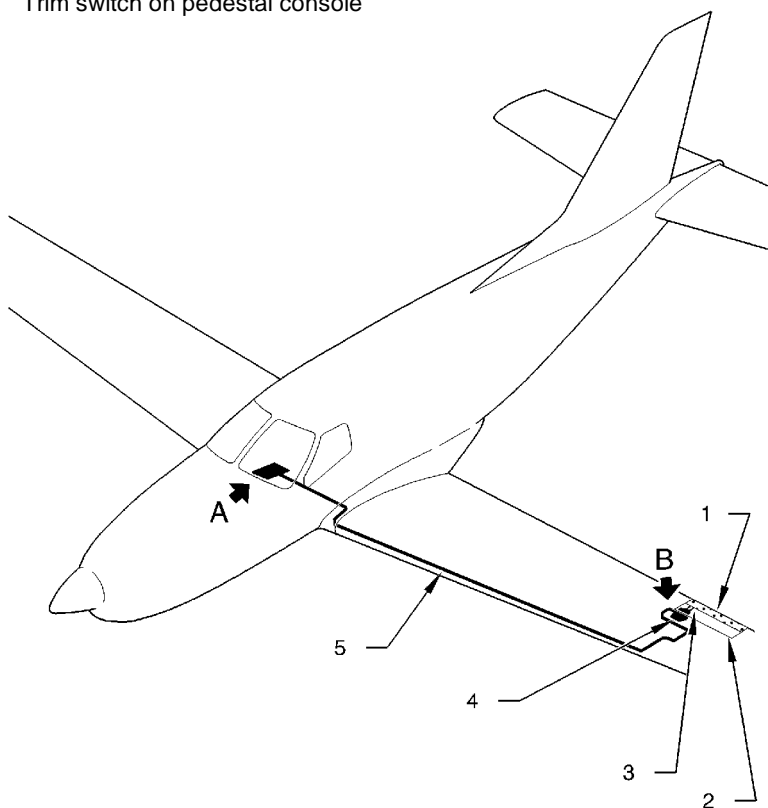

14271000AAAYMA8003

Figure 7.4.2 (1/2) - Lateral trim

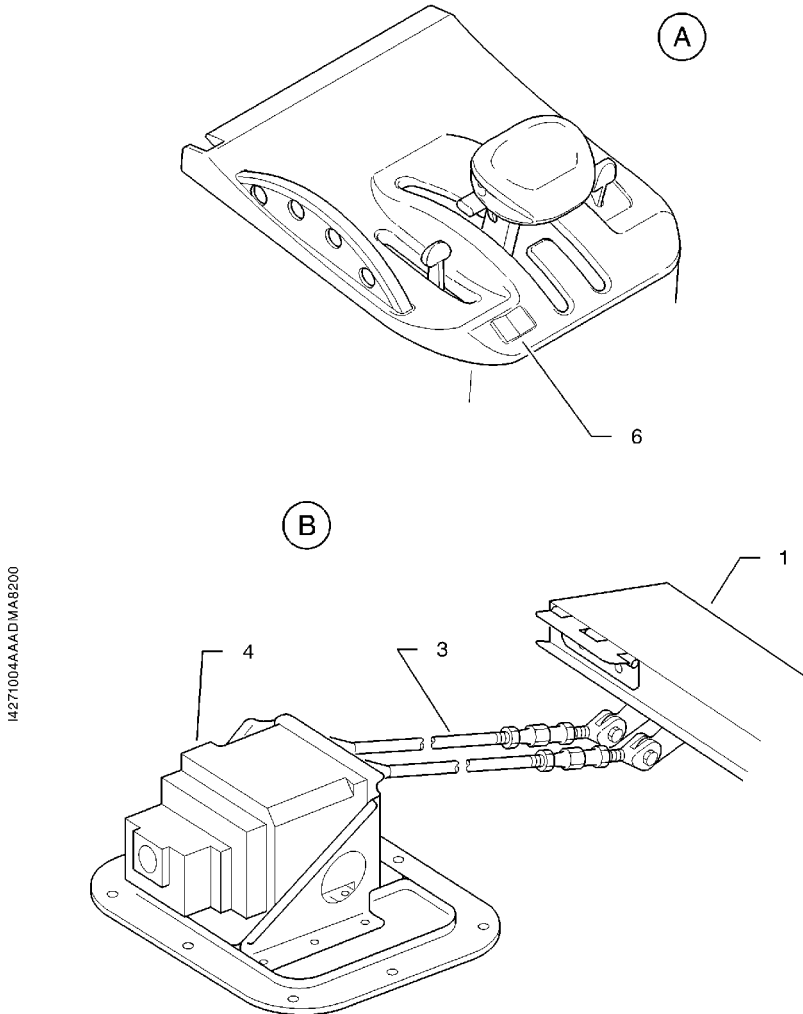

14271004AAA.DMA8200

Figure 7.4.2 (2/2) - Lateral trim

Elevator - see figure 7.4.3

Both elevators are activated simultaneously by the same control. Each control surface is hinged at three points to the rear part of horizontal stabilizer.

The control wheel controls the two elevators through rods, bearings and bellcranks.

A stick shaker is fixed on the pitch lever linked to the pilot control column lever. This is a mechanical device to vibrate the control wheel to warn the pilot in case of an imminent stall. When the data received from the AoA (angle of attack) sensor indicates an imminent stall, the AoA computer actuates both the stick shaker and the stall warning.

A spring actuator creates a nose-down artificial force which allows a better static stability.

Each control surface is provided with an automatic anti-tab (automaticity about 0.3), which is also used as trim tab.

Pitch trim - see figure 7.4.4

The pitch trim is accomplished through the two anti-tabs located on left and right elevators.

The trim tab can be controlled electrically or manually. It is activated through cables and a chain on two screw actuators attached to the horizontal empennage.

The electrical control consists of a switch (NOSE UP - NOSE DOWN) located on the pilot control wheel and a servo-motor attached under the pedestal.

The electrical circuit for pitch trims is protected by the AP SERVOS breaker.

Manual control wheel is installed vertically on left side of pedestal console.

- 1) Control wheel assembly
- 2) Elevators
- 3) Lever assembly, fuselage rear part
- 4) Elevator bellcrank
- 5) Rod with presseal connection
- 6) Lever assembly under floor
- 7) Pedestal assembly
- 8) Actuator
- 9) Stick shaker

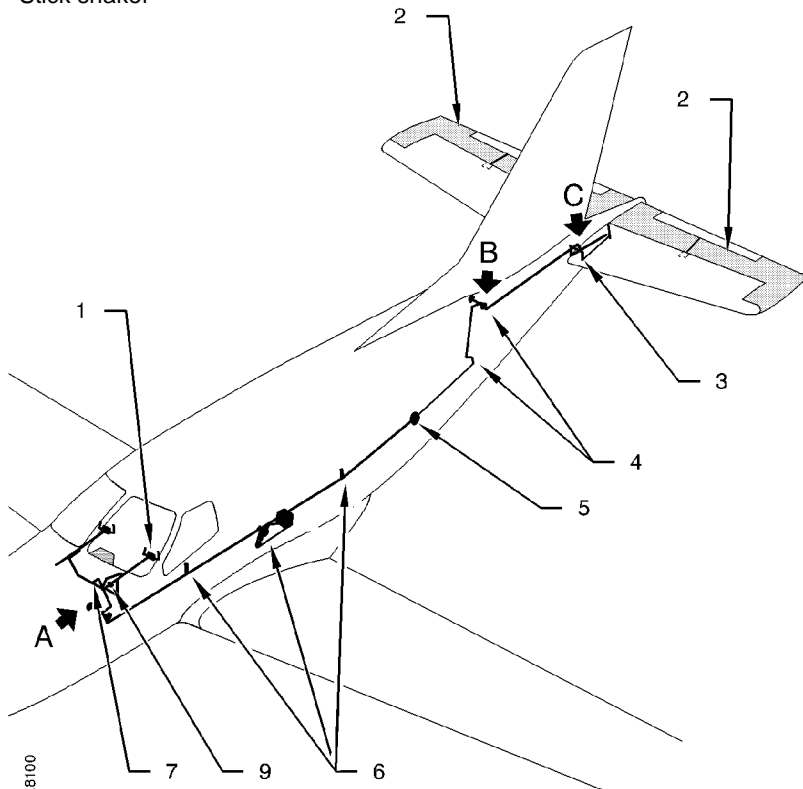

14273000A-AAAAB100

Figure 7.4.3 (1/2) - Elevator

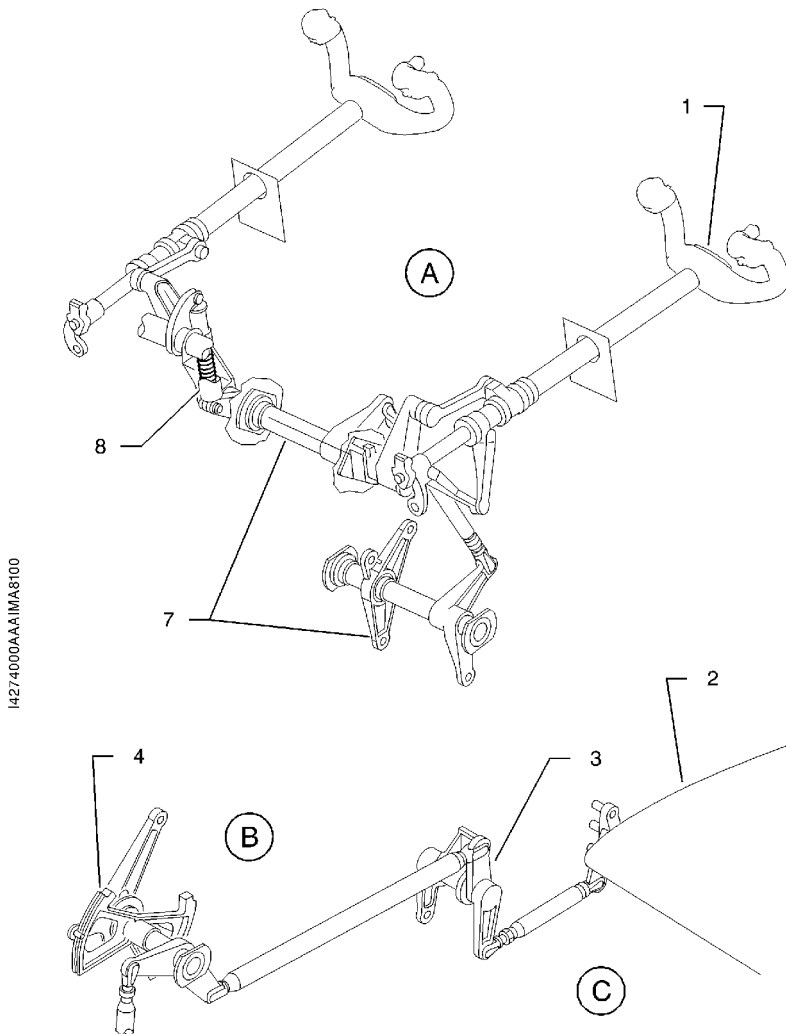
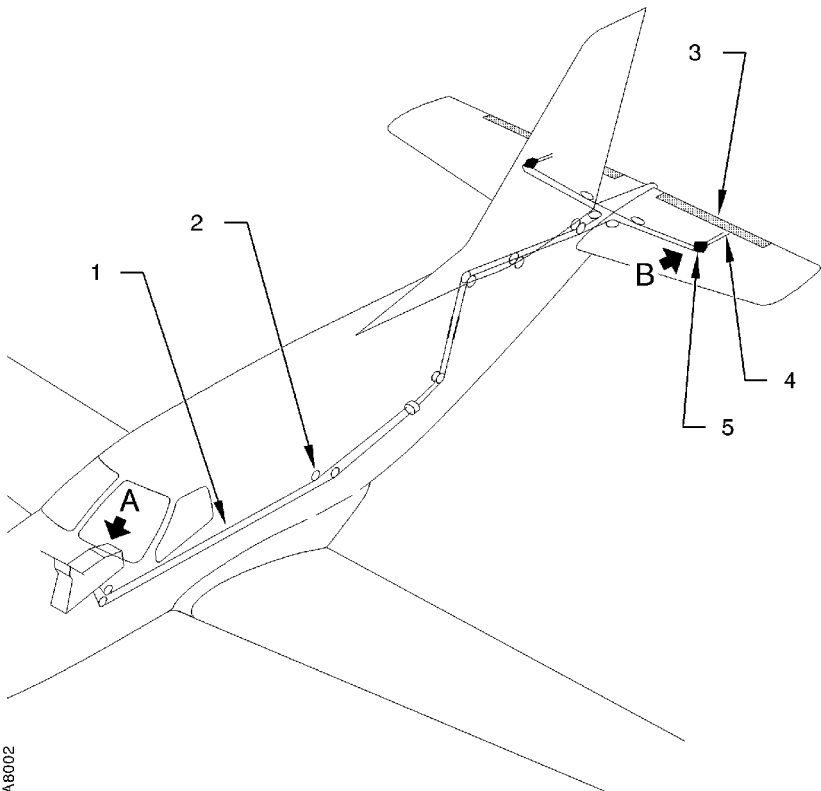

Figure 7.4.3 (2/2) - Elevator

- 1) Cables
- 2) Pulleys
- 3) Pitch trim tabs
- 4) Actuating rods
- 5) Actuator
- 6) Pitch trim manual control wheel
- 7) Electric pitch trim control



14274000AAABMA8002

Figure 7.4.4 (1/2) - Pitch trim

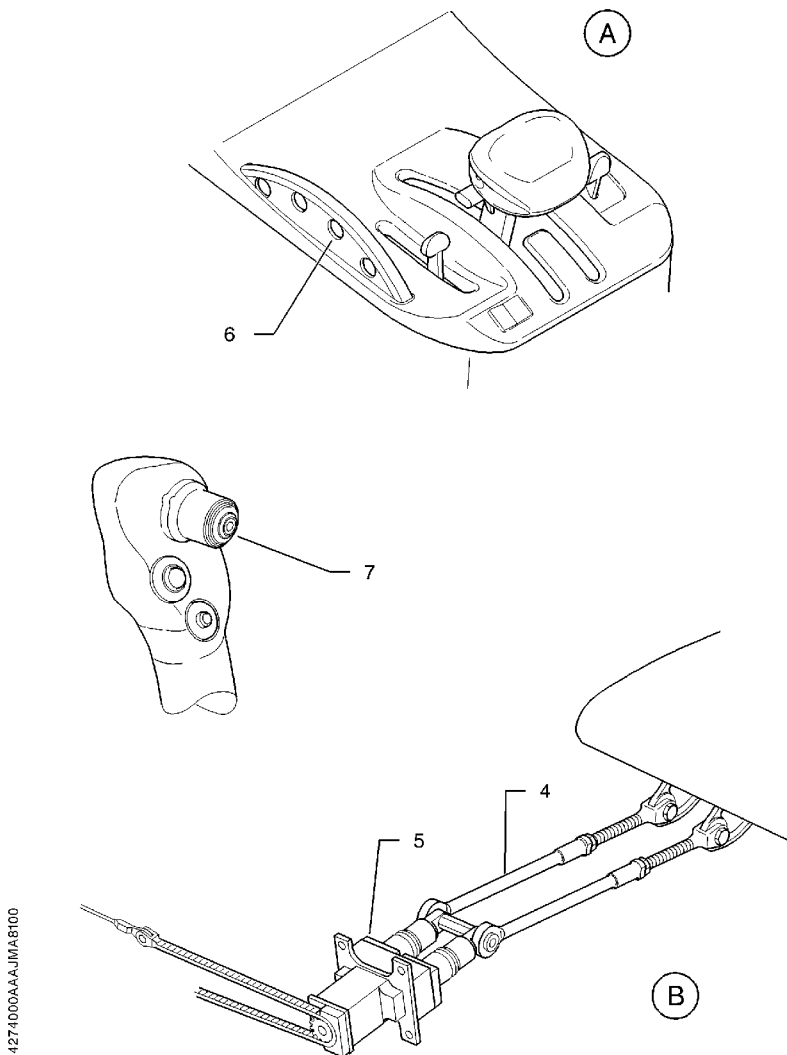

Figure 7.4.4 (2/2) - Pitch trim

Rudder - see figure 7.4.5

The rudder is hinged on three fittings attached to the vertical stabilizer rear spar.

The rudder pedals / rudder linkage is ensured through cables and a rod.

Pilot and R.H. station rudder pedal positions are adjustable at each station. The rudder pedal adjustment mechanism (for piloting comfort purposes) includes a manual control located against the external bulkhead beneath the instrument panel and a locking device on the rudder pedals. This ball locking device allows selecting six different positions.

When landing gear is down, rudder pedals are linked to nose gear steering system.

Spring system of rudder / roll combination induces aileron deflection at the time of pedal displacement and vice versa.

Rudder trim - see figure 7.4.6

A trim tab hinged at two points located at rudder trailing edge provides rudder trim.

Trim tab is linked by two rods to an electric actuator attached to rudder. It is controlled by rudder trim switch (Y L / Y R) located on pilot control wheel.

Electrical circuit of rudder trim tab is protected by RUD TRIM breaker.

- 1) Roll / rudder combination bellcrank installation
- 2) Rudder pedals assembly
- 3) Control cables
- 4) Pulleys
- 5) Rudder lever assembly
- 6) Rod
- 7) Rudder
- 8) Nose gear steering rod

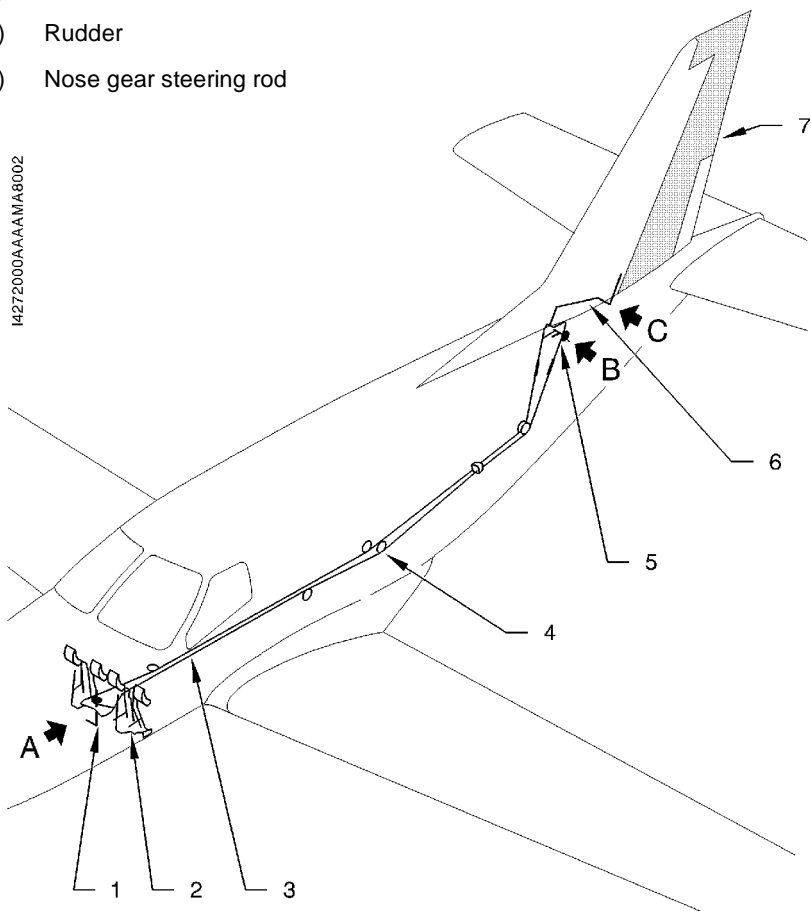

Figure 7.4.5 (1/2) - Rudder

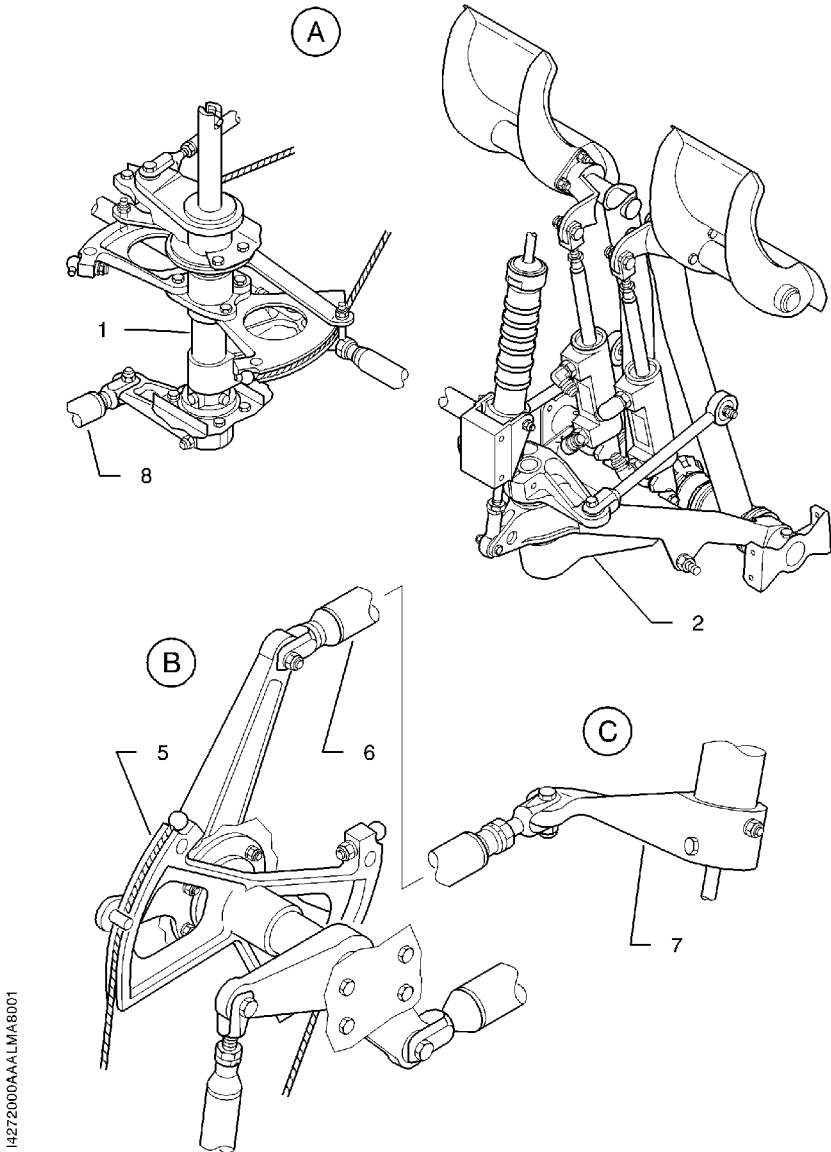

Figure 7.4.5 (2/2) - Rudder

- 1) Trim switch on control wheel
- 2) Actuator
- 3) Rudder trim tab
- 4) Rods
- 5) Rudder trim control wiring

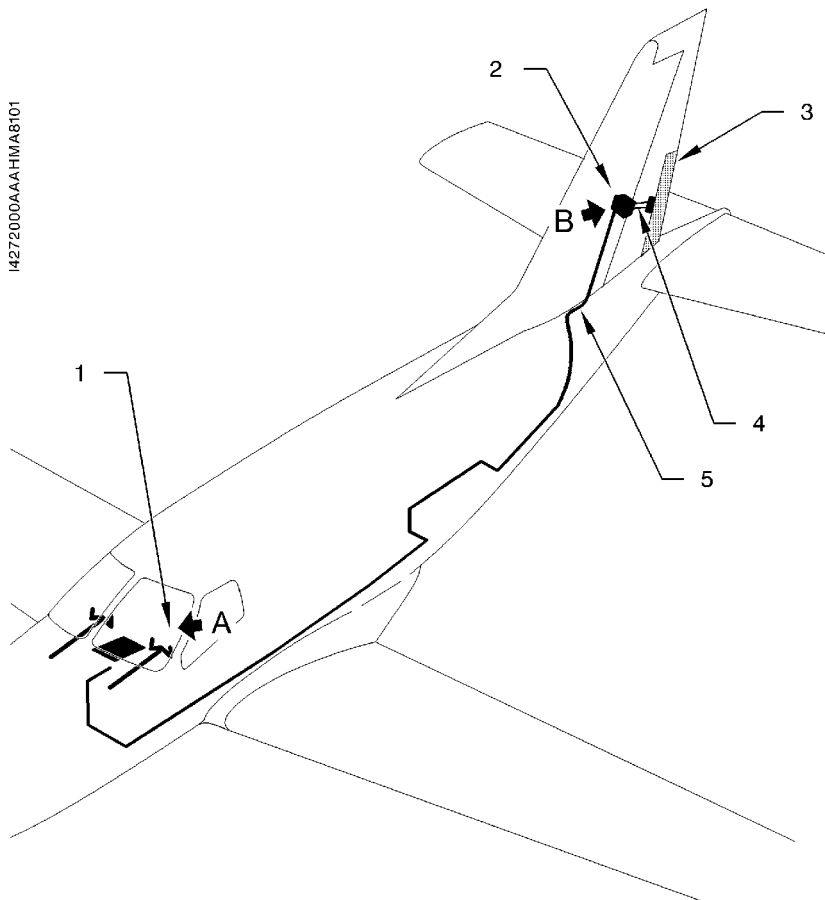
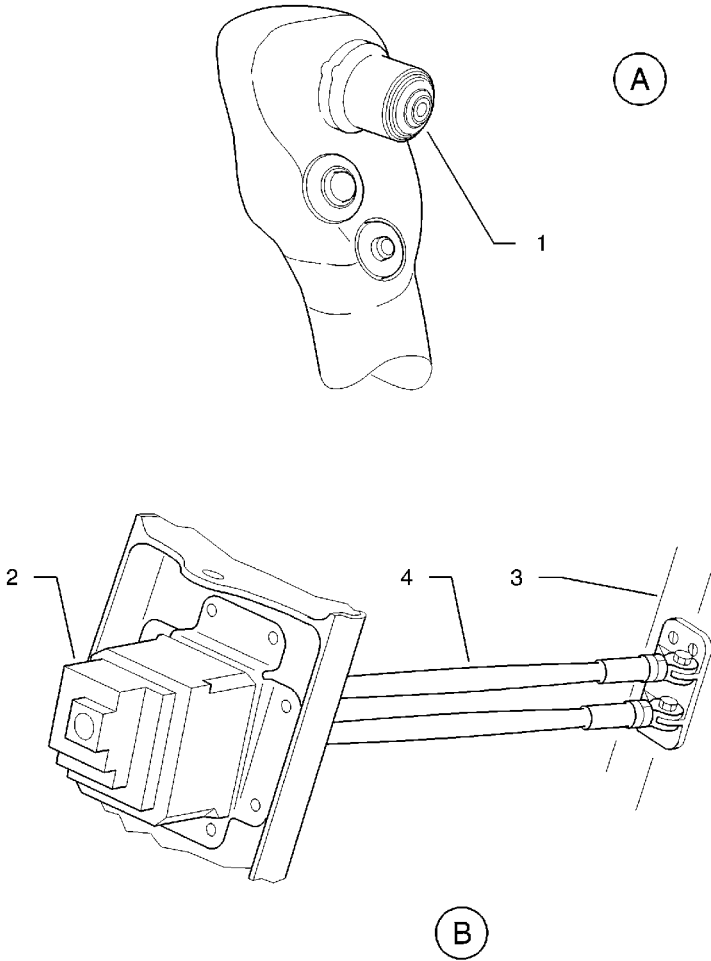

Figure 7.4.6 (1/2) - Rudder trim



14272002AAAAGMA8200

Figure 7.4.6 (2/2) - Rudder trim

Intentionally left blank

7.5 - Landing gear

The airplane is equipped with electro-hydraulically actuated, fully retractable tricycle landing gear.

Each landing gear is equipped with one wheel and an oil-air shock absorber integrated in the strut.

Main landing gears swivel on two ball joints installed on wing spars. Each landing gear retracts toward airplane centerline. The operation is accomplished by a hydraulic actuating cylinder which also provides up and down locking.

Nose gear swivels on two ball joints installed on a tubular steel mount frame. Its operation is accomplished by a hydraulic actuating cylinder which also provides up and down locking. The nose wheel is steerable. It is connected to pedals through a spring rod and is provided with a shimmy damper. In UP position, nose wheel is automatically disconnected.

Actuating cylinders have a locking device integrated at both ends. This device maintains landing gear in up or down position.

Landing gear doors, two on the nose gear, two on each main landing gear, are driven and kept in UP position by the landing gear itself.

All doors are mechanically kept in down position.

Hydraulic pressure

Hydraulic pressure required for landing gear operation is provided :

- during normal operation, by an electro-hydraulic generator with integrated reservoir,
- during emergency extension operation by a hand pump supplied with an auxiliary reservoir.

Landing gear lever - see figure 7.5.1

LANDING GEAR lever, located on LANDING GEAR panel at the bottom of instrument panel left part, is accomplished by an electric selector actuated through a lever ending with a knob representing a wheel. Operation is carried out by pulling on lever and by putting it in the desired UP (retracted) or DN (extended) position. This selector controls hydraulic generator.

Landing gear position indicator - see figure 7.5.1

■ Landing gear position indication is displayed by 5 lights :

- On LANDING GEAR control panel
 - . 3 green indicator lights (one per landing gear),
 - . 1 red warning light GEAR UNSAFE
 - . 1 amber light in the LANDING GEAR lever.
- On MFD CAS window :
 - . **GEAR UNSAFE**

● NOTE ●

The amber light flashes while the hydraulic pump is operating to extend or retract the landing gear.

●

When landing gear is correctly retracted, all lights are OFF.

Down-locked correct indication is when there are 3 green indicator lights ON, the GEAR UNSAFE red warning light is OFF, the **GEAR UNSAFE** is OFF and the amber caution light is OFF. All other cases mean the gear is not down-locked.

■ If there is a doubt about the landing gear in the down-locked position, an independent electrical circuit provides a countercheck capability of the indicator system. Pressing the CHECK DOWN push-button, located on the LANDING GEAR panel, confirms the gear down and locked with a rapid flash rate (16 hertz) ; when flashing, each green indicator light indicates that the corresponding gear is down and locked.

Pressing the LIGHT TEST push-button enables the testing of all LANDING GEAR panel lights, making them flash at a low rate (1 hertz).

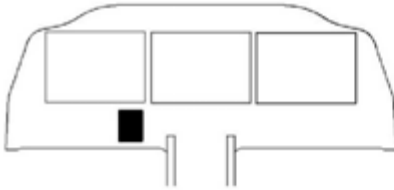

- 1) Green indicator light
- 2) Red warning light
- 3) LANDING GEAR lever
- 4) CHECK DOWN push-button
- 5) LIGHT TEST push-button
- 6) Amber light

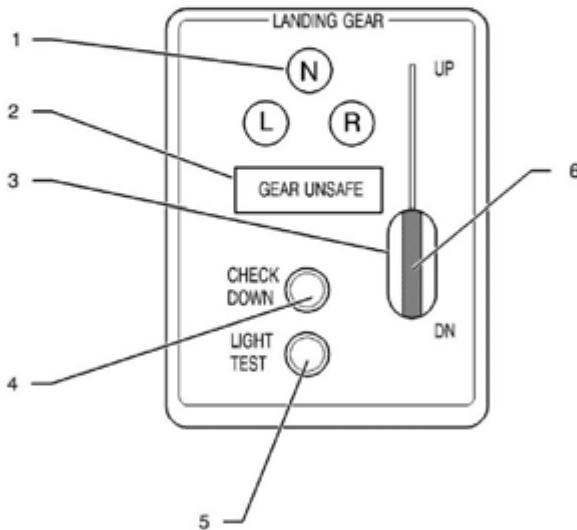

Figure 7.5.1 - Control panel and landing gear indicating

Safety

Safety switch - landing gear retraction

A safety switch installed on each main landing gear prevents, by detecting shock strut compression, landing gear accidental retraction when airplane is on ground.

Landing gear aural warning

Landing gear / Landing gear aural warning alert sounds when :

- THROTTLE is on IDLE position and landing gear is not down-locked,
- flaps are beyond TO position (Takeoff) and landing gear is not down-locked.

• NOTE •

If one of above conditions exists and airplane is in stall configuration, the Stall/landing gear aural warning alert sounds and the control wheel vibrates.



Emergency landing gear extension control - see figure 7.5.2

Emergency landing gear extension control consists of a hand pump and a by-pass selector.

This control is accessible by removing the floor panel located aft of the pedestal.

After bypass selector closing, hand pump operation sends hydraulic fluid directly into landing gear actuators ; landing gear full extension and locking requires up to 110 cycles.

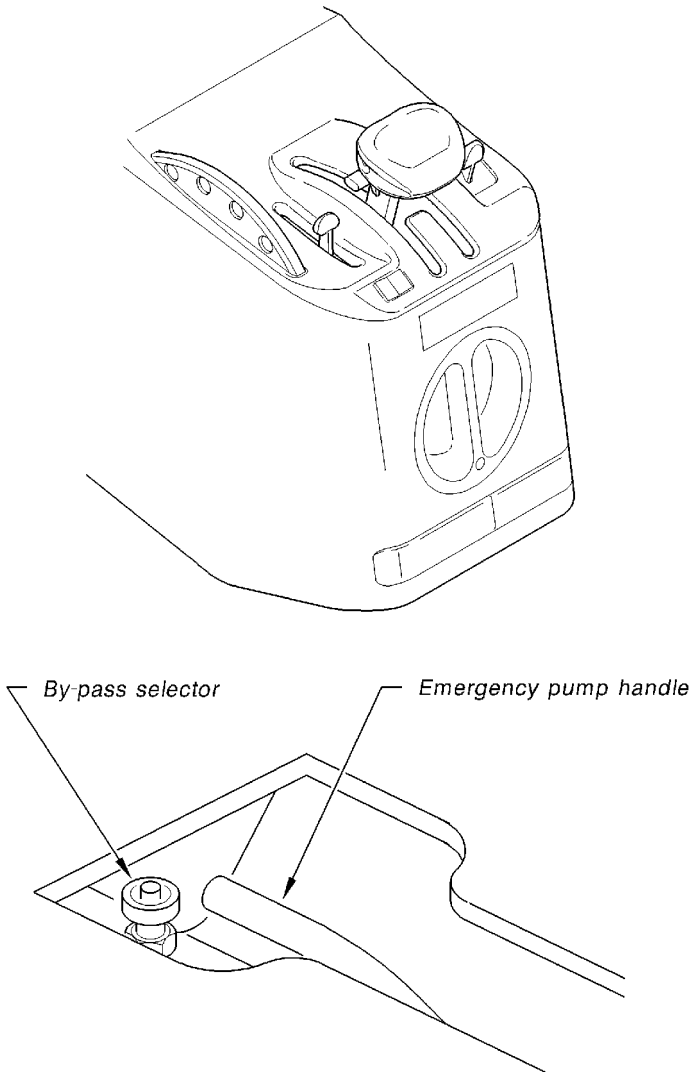

Figure 7.5.2 - Emergency landing gear extension control

Ground maneuvers

Nose gear steering control - see figures 7.5.3 and 7.5.4

Nose gear steering control is combined with rudder pedals and is fitted with a shimmy damper. When one of rudder pedals is fully pushed, nose wheel swivels about 20°. Steering may be increased up to 28° by applying differential braking to each side.

Airplane may be towed by attaching a steering or towing bar on nose gear, refer to chapter 8.6 for operation. In that case nose wheel steering angle is limited to $\pm 28^\circ$.

Minimum turn diameter

Minimum turn diameter, figure 7.5.4, is obtained by using nose gear steering and differential braking.

▲ CAUTION ▲

Since tight turns lead to untimely tire wear, turns should be made using the largest possible turning radius.



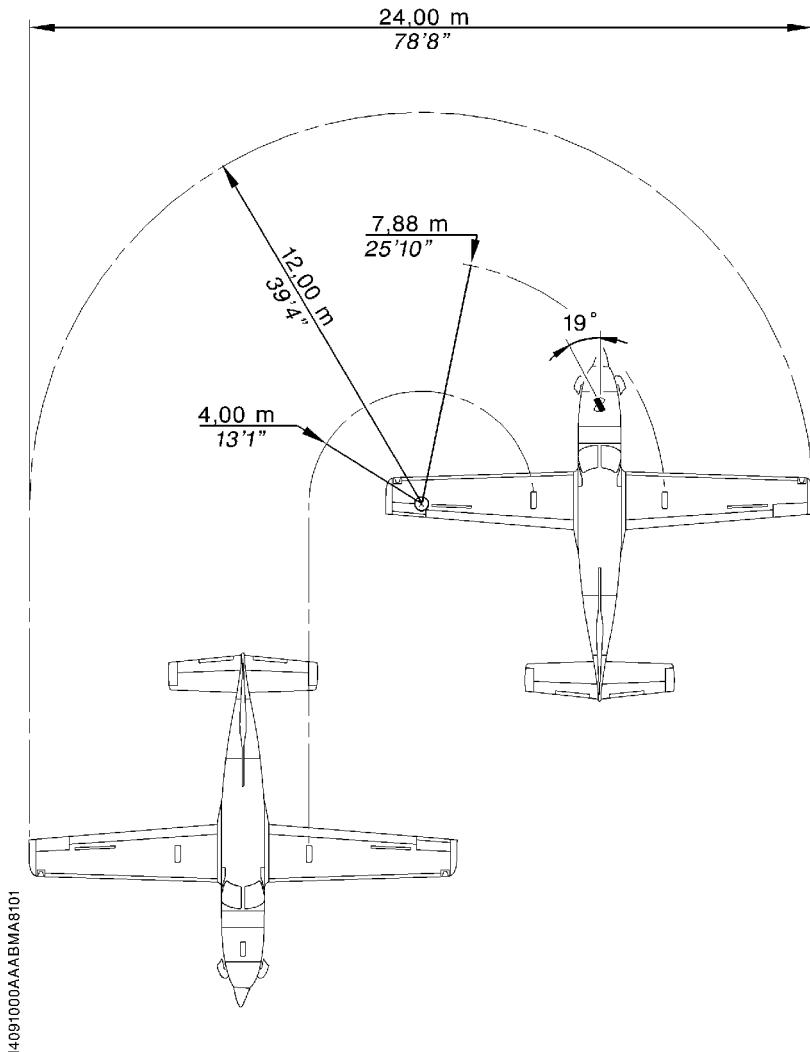

Figure 7.5.3 - Minimum turn diameter
(Full rudder pedals travel without using differential braking)

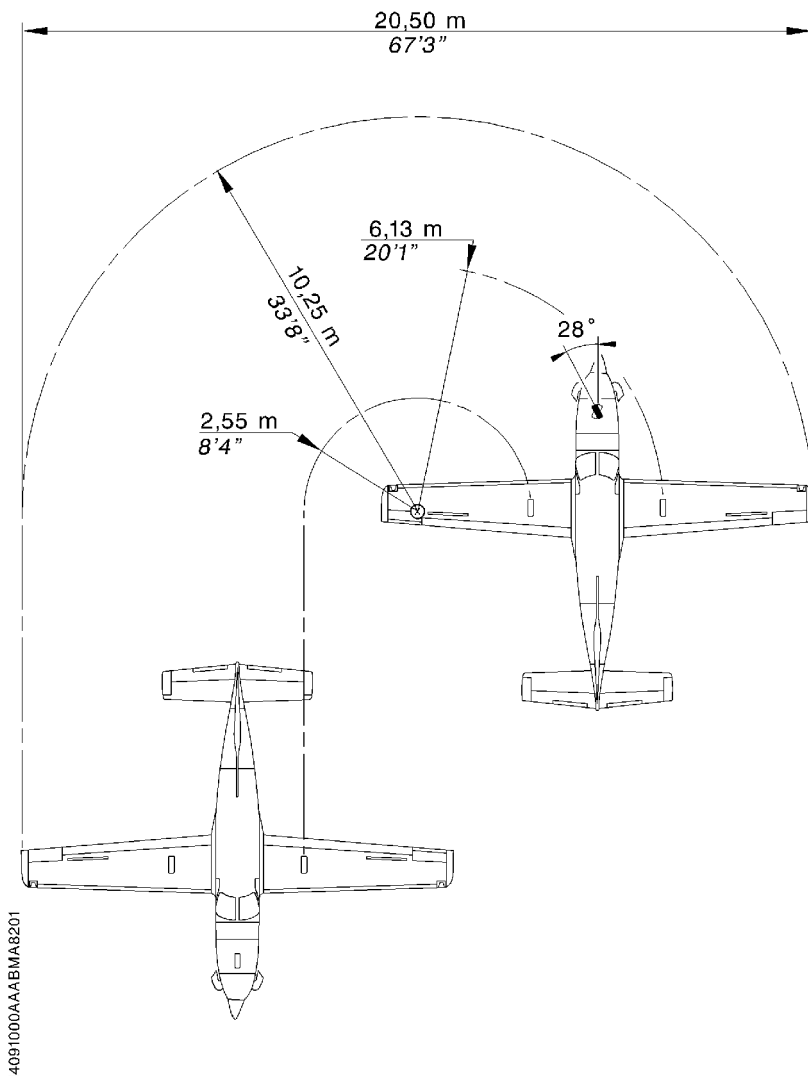

Figure 7.5.4 - Minimum turn diameter
(Full rudder pedals travel by using differential braking)

Brake system - see figure 7.5.5

The airplane is equipped with a hydraulically actuated disc braking system installed on the main landing gear wheels.

Each toe brake at pilot and front passenger stations is equipped with a master cylinder which sends hydraulic pressure to the corresponding disc brake : left pedals, left-side brake ; right pedals, right-side brake. Use differential braking to assist in maneuvering during taxiing.

Parking brake - see figures 7.5.5 and 7.5.6

Parking brake control consists of a control knob located on pilot's side lower instrument panel and a valve which regulates brake pressure.

To apply the parking brake, press on the rudder pedals' toe brake and set the control knob to ON.

PARK BRAKE is ON when the control knob is set to ON.

● NOTE ●

Operating the parking brake knob without applying pressure on rudder pedals does not cause the wheels to be braked.



▲ CAUTION ▲

Failure to apply brake pressure while releasing the parking brake can damage the parking brake valve. This damage can cause the parking brake valve to not release the pressure.



To release the parking brake, press on the rudder pedals' toe brake and set the control knob to OFF. Check that **PARK BRAKE** disappears at the same time.

- 1) Reservoir
- 2) Vent
- 3) R.H. station master cylinders
- 4) PARK BRAKE control knob
- 5) PARK BRAKE valve
- 6) Drain
- 7) Pilot's station master cylinders
- 8) L.H. brake assembly
- 9) R.H. brake assembly

Figure 7.5.5 (1/2) - Brake system

Key

- █ Supply hose
- █ Flexible pressure pipe
- █ Rigid pressure pipe

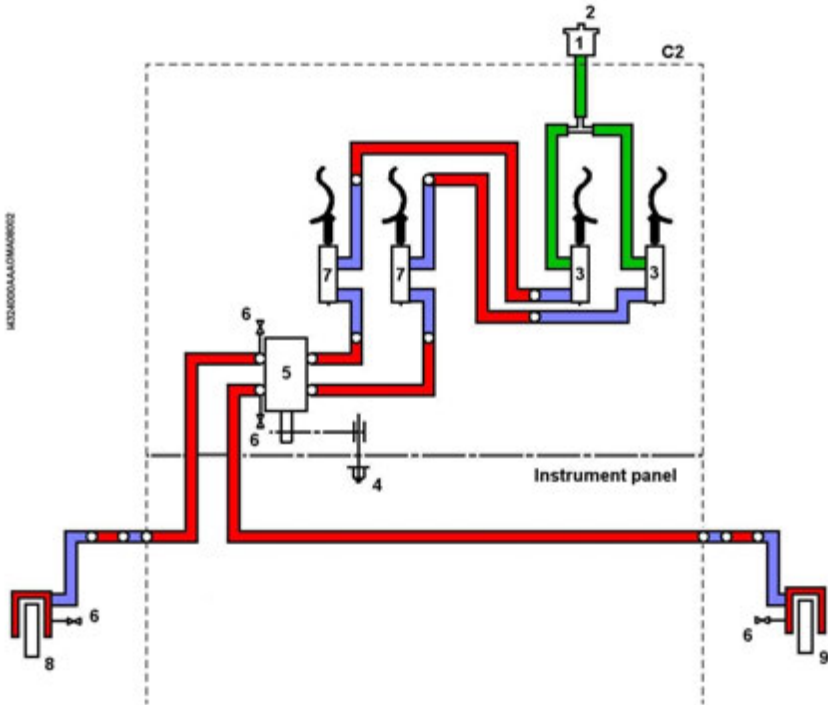
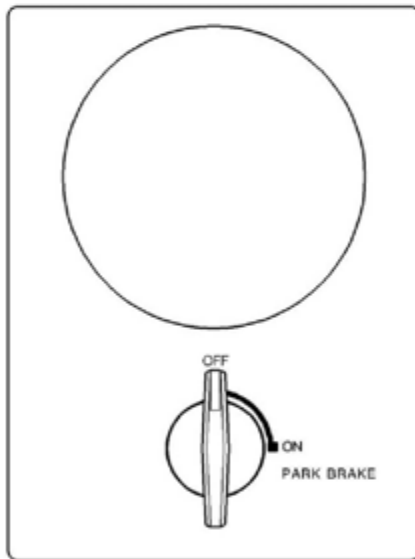
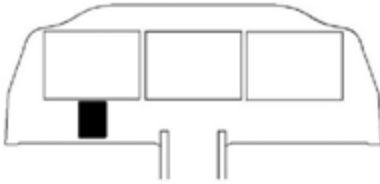

Figure 7.5.5 (2/2) - Brake system



143515700A-00-AMA-183200

Figure 7.5.6 - Brake system

7.6 - Powerplant

Turboprop engine operation - see figure 7.6.1

The PRATT & WHITNEY CANADA turboprop engine (PT6A-66D model) is a free turbine engine rated at 850 SHP and developing a thermodynamic power of 1825 ESHP.

Intake air enters engine through an annular casing and is then ducted toward compressor. The latter consists of four axial stages and one single centrifugal stage assembly to form a whole assembly. Compressed air and fuel are mixed and sprayed into combustion chamber by fuel nozzles. The mixture is first ignited by two spark igniter plugs, then combustion continues as a result of air-fuel mixture flow. Gases resulting from combustion expand through a series of turbines. The first one (gas generator turbine) drives compressor assembly and accessories, the two other ones (power turbines), independant from the first one, drive propeller shaft through a reduction gear box. Hot gases are evacuated through two exhaust stubs located laterally on both sides forward of engine cowling.

All engine driven accessories, except power turbine tachometer, propeller governor and overspeed governor are installed on accessory gearbox located rearward of engine.

- 1) Propeller governor
- 2) Exhaust stub
- 3) Axial compressors
- 4) Accessory gearbox
- 5) FCU Fuel Control Unit
- 6) Oil to fuel heater
- 7) Input coupling shaft
- 8) Air intake
- 9) Centrifugal impeller
- 10) Combustion chamber
- 11) Compressor turbine
- 12) Power turbine 1st stage
- 13) Power turbine 2nd stage
- 14) Power turbine shaft

Figure 7.6.1 (1/2) - Powerplant

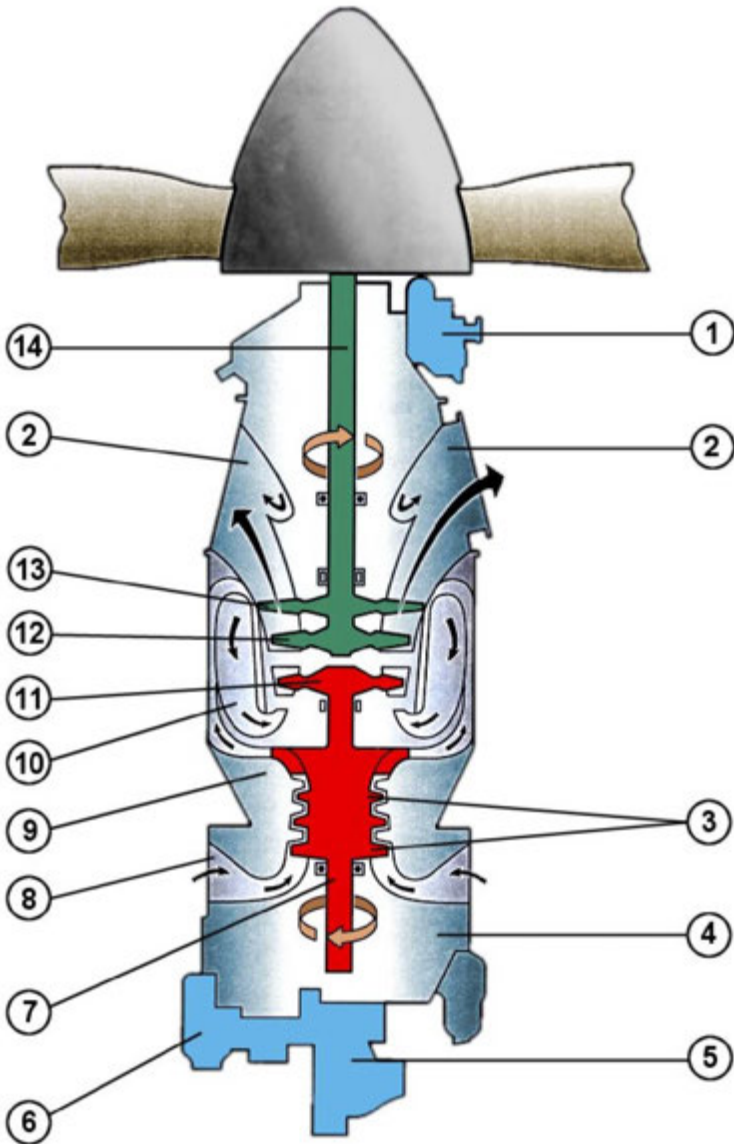

Figure 7.6.1 (2/2) - Powerplant

Engine control levers - see figure 7.6.2

Engine operation requires use of two levers located on pedestal console in cabin :

- THROTTLE (Item 1), and its detent for reverse (Item 4)
- MAN OVRD control for emergency fuel regulation (Item 3).

• NOTE •

Thumbwheel for lever friction (Item 2).

•

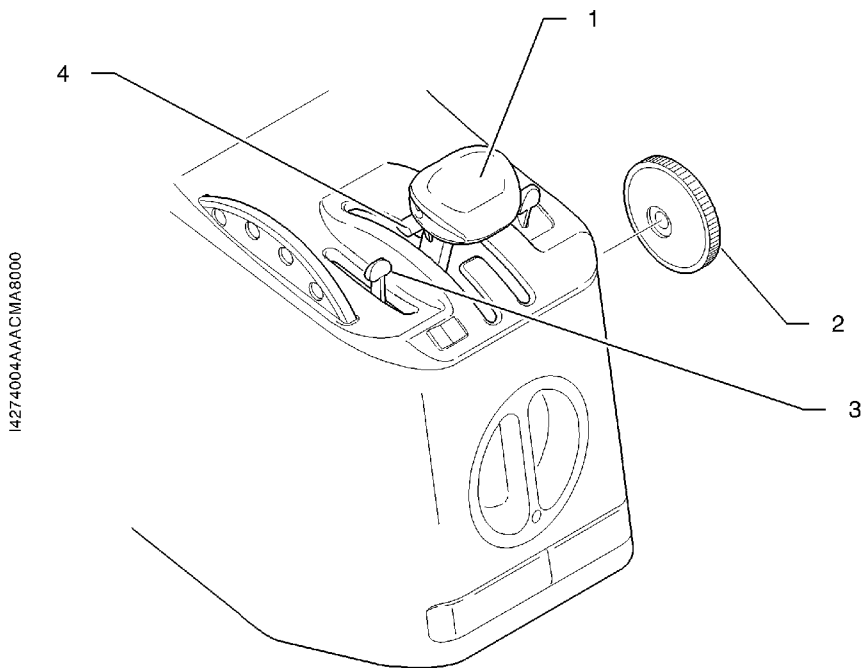

Figure 7.6.2 - Engine control levers

THROTTLE - see figure 7.6.3

The THROTTLE has two operating modes : thrust mode and condition mode.

- Thrust mode

The THROTTLE is in vertical position. It modulates engine power from full reverse to max power.

Engine running, the throttle rearward displacement, past the lock using the detent, allows to control :

- the engine power in the Beta range from idle to maximum reverse,
- the Beta valve to select the propeller pitch in reverse.

Return to idle position is accomplished by pushing the THROTTLE forward.

▲ **CAUTION** ▲

Do not move the cockpit THROTTLE into the propeller reverse position or damage to the linkage will result.

Reverse may only be selected with engine running and propeller turning.

■ Moving the THROTTLE rearward past the idle stop may damage or break the flexible control cable.



When engine is shutdown, there is no oil pressure in the propeller and the feathering spring locks the Beta ring and the propeller reversing interconnect linkage on the engine.

- Condition mode

The THROTTLE is moved to the condition side by lifting the knob.

As long as the THROTTLE is in condition mode, the propeller is in feather position. The THROTTLE can be positioned to CUT OFF, idle LO-IDLE or idle HI-IDLE.

Change from idle HI-IDLE to LO-IDLE position requires moving the THROTTLE rearwards.

Change from idle LO-IDLE to CUT OFF position is only possible after having overridden the idle gate. To override idle gate, raise the THROTTLE and move it rearwards.

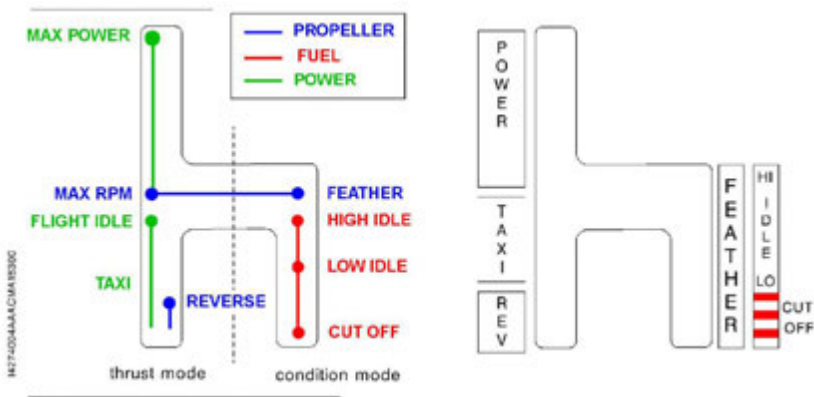

Figure 7.6.3 - THROTTLE

MAN OVRD control - see figure 7.6.2

MAN OVRD control (3) is normally notched in full backward position. In case of FCU or THROTTLE failure, it allows setting engine power manually.

To quit full backward position (notched), move the MAN OVRD control forward overriding the indexation.

• NOTE •

The power available if the THROTTLE fails will be limited by the position of the lever.

•

Lever friction - see figure 7.6.2

A thumbwheel (Item 2) located on right side of pedestal console increases friction to avoid control slip of the THROTTLE after setting.

Engine instruments

Engine indicating consists of :

- engine torque expressed in percent (%), TRQ
- propeller speed in RPM, PROP RPM
- generator rotation speed expressed in percent (%), Ng
- ITT expressed in °C,
- oil pressure expressed in PSI.
- oil temperature expressed in °C.

• NOTE •

Engine monitoring is ensured by **ITT** and **OIL PRESS** .

Refer to the GARMIN Pilot's Guide for further details.

•

Engine lubrication

Engine oil is in a tank incorporated into the powerplant. It ensures lubrication and engine cooling. A cooler located on left side in engine compartment maintains oil temperature within limits. Oil flow into the cooler is metered by a thermostatic valve. Engine oil also supplies propeller governor and engine torquemeter.

A chip detection system enables the monitoring of engine oil system. The system includes one chip detector installed on propeller reduction gear box and a second chip detector installed on engine accessory gear box. In case of chip detection, **CHIP** will appear on integrated flight deck system screen.

Lubrication system content, cooler included, is 12.7 quarts (12 litres). A graduated dipstick allows checking oil quantity in system. A visual oil sight glass, located on engine left side, allows a rapid checking of oil level.

• NOTE •

For checking and oil filling-up, refer to section 8.

•

Engine starting - see figure 7.6.4

Ignition function

Ignition system consists of an ignition unit and two spark igniter plugs in powerplant, a three-position IGNITION switch OFF - AUTO - ON located on ENGINE START panel at upper panel.

Ignition unit supplies, from 28-volt source, high voltage current necessary to spark igniter plugs. When IGNITION switch is positioned to AUTO, ignition unit supply is ensured during the engine start.

IGNITION lights on as long as ignition unit is supplied.

Starter function

Starting system consists of STARTER switch located on ENGINE START panel, starter generator and ignition circuit (Refer to paragraph Ignition function).

Starting procedure is semi-automatic. Setting STARTER switch to ON connects the starter generator which drives powerplant. **STARTER** lights on indicating that the starter generator is operating.

Starter operation is stopped automatically by the electrical power system once a sufficient starter-generator speed is reached or after 60 s. The pilot has the capability to interrupt the start process anytime by setting momentarily the STARTER switch to the ABORT position.

▲ WARNING ▲

Powerplant starting must be performed by qualified personnel and following procedures and parameters described in section 4 Normal procedures.



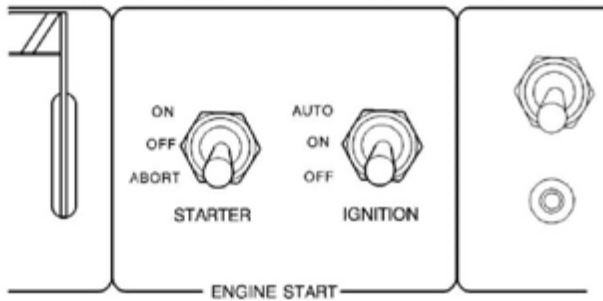
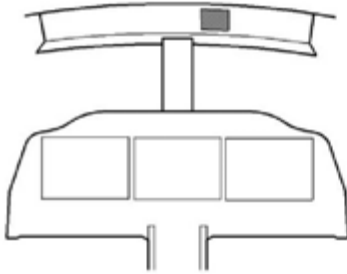

142-0000AAA-JMA8100

Figure 7.6.4 - Engine starting

Engine air inlet

Engine air inlet is located at front lower section of engine cowling. Air inlet port is protected against icing by a hot air flux provided by engine. Air is driven throughout a duct in engine casing before entering engine through a protective screen. An inertial separator system inside the air duct protects the engine from ingesting dense particles (water, ice, fine gravels, sand).

Separator consists of two movable vanes. During normal operation, air is conducted directly towards engine air inlet. To separate particles suspended in the air, vanes are positioned to force engine induction air to execute a sharp turn : under the effect of centrifugal force denser particles separate from the air and are discharged overboard through two apertures located under engine cowling.

Operation of inertial separator vanes is electrically controlled by INERT SEP switch located on DE-ICE SYSTEM panel. When INERT SEP switch is set to ON, an electric actuator activates vanes ; **INERT SEP ON** lights on when vanes have reached their maximum deflection and remains visible as long as switch remains ON. Full deflection takes about 40 seconds. If the vanes do not reach the full deflection 50 seconds after activation or are not retracted 50 seconds after deactivation,

INERT SEP FAIL is displayed in CAS window.

Exhaust system

Exhaust gases are evacuated through exhaust stubs located on sides of engine cowlings.

Engine accessories

All engine driven accessories, except power turbine tacho-generator (Np), propeller governor and overspeed governor, are installed on accessory gearbox located rearwards of engine.

Oil pump

Oil pump is a self-controlled gear pump located at the bottom of oil casing.

Fuel high pressure pump (HP)

Fuel high pressure pump is installed on accessory gearbox. It supplies fuel nozzles, flow being controlled by fuel regulator (FCU). Fuel provided by engine driven main pump (mechanical) enters high pressure pump through a filter, then it is discharged under pressure into fuel regulator (FCU) through a second filter. In case of contamination of this second filter, a by-pass valve allows fuel to go directly from high pressure pump to the regulator.

Compressor turbine tacho-generator (Ng)

Compressor turbine tacho-generator (Ng) is attached on accessory gearbox. It supplies a voltage which is transmitted to the GARMIN system for display on the MFD, under normal display conditions.

Power turbine tacho-generator (Np)

Power turbine tacho-generator is attached on the right side of the reduction gearbox. It supplies a voltage which is transmitted to the GARMIN system for display on the MFD, under normal display conditions.

Torque transmitter

Torque transmitter is attached on the torque limiter, it measures torque produced by the power turbine by comparing oil pressures (reduction gear and power turbine) and converts pressure difference into a voltage. This voltage is transmitted to the GARMIN system for display on the MFD, under normal display conditions.

Propeller overspeed limiter

Propeller overspeed limiter is installed on left side of the reduction gear box. It prevents a propeller overspeed in case of main propeller governor failure.

Propeller overspeed limiter is equipped with a solenoid which makes feather the propeller when the THROTTLE is in condition mode.

Torque limiter

Torque limiter is located on right side of the reduction gear box. It is rated to limit engine torque to 109-110 % at sea level.

Propeller

Airplane is equipped with a composite five-bladed, constant-speed and full-feathering propeller.

Regulation

Propeller governor located on engine maintains rotation speed to the nominal value of 2000 RPM. Regulation is obtained through propeller blade pitch variation : counterweights drive propeller blades toward high pitch (low RPM) whereas oil pressure delivered by governor drives back blades toward low pitch (high RPM).

Propeller governor allows feathering either by voluntary pilot action via THROTTLE (Condition mode) or automatically in case of engine failure or shutdown.

Propeller reverse pitch allows reduced taxiing speed or landing roll. Change from idle to reverse position is performed with THROTTLE (Thrust mode) - refer to paragraph Engine controls.

7.7 - Fuel system - see figure 7.7.1

The fuel system comprises fuel tanks, fuel unit, selectors, manual and automatic, electric and mechanical boost pumps, engine fuel system, gaging installation, monitoring installation and drains.

Fuel tanks

Fuel tanks are formed by sealed casings in each wing. Each fuel tank comprises a filling port located at the end of wing upper surface, two drain valves located at the lower surface (one near main landing gear, at trailing edge side, the second one near wing root side, at leading edge), a vent valve located on the lower surface, a suction strainer and three level gages.

Fuel unit

The fuel unit combines shut-off valve, tank selector and filter functions. It is connected to the manual selector through a mechanical control. The fuel filter is located in a bowl at the lower part of the unit. It is fitted with a by-pass valve, a clogging indicator and a drain valve.

Tank manual selector - see figure 7.7.2

The FUEL TANK SELECTOR is located on the pedestal rear face. It allows selecting manually the tank (R or L) to be used and setting unit to OFF. To change from L position to OFF position, turn the selector clockwise (L → R → OFF) ; change from R position to OFF position requires a voluntary action from the pilot (pull and turn). The pull and turn maneuver prevents involuntary operation. When the unit is set to OFF,

FUEL OFF remains visible.

- | | |
|-----------------------------------|------------------------|
| 1) Flow divider | 14) Fuel unit |
| 2) Flowmeter | 15) Filter drain |
| 3) Collector tank | 16) Fuel return pipe |
| 4) Fuel regulator | 17) Filling port |
| 5) High pressure pump (HP) | 18) NACA scoop |
| 6) Oil to fuel heater | 19) Tank vent valve |
| 7) Low pressure switch | 20) Fuel level gages |
| 8) Fuel jet | 21) Tank drain valve |
| 9) Main mechanical boost pump | 22) Check-valve |
| 10) Electric boost pump | 23) Low level detector |
| 11) Fuel filter | 24) Suction strainer |
| 12) Filter clogging by-pass valve | 25) Fuel amplifier |
| 13) Filter clogging indicator | 26) Sequencer |

Figure 7.7.1 (1/2) - Fuel system

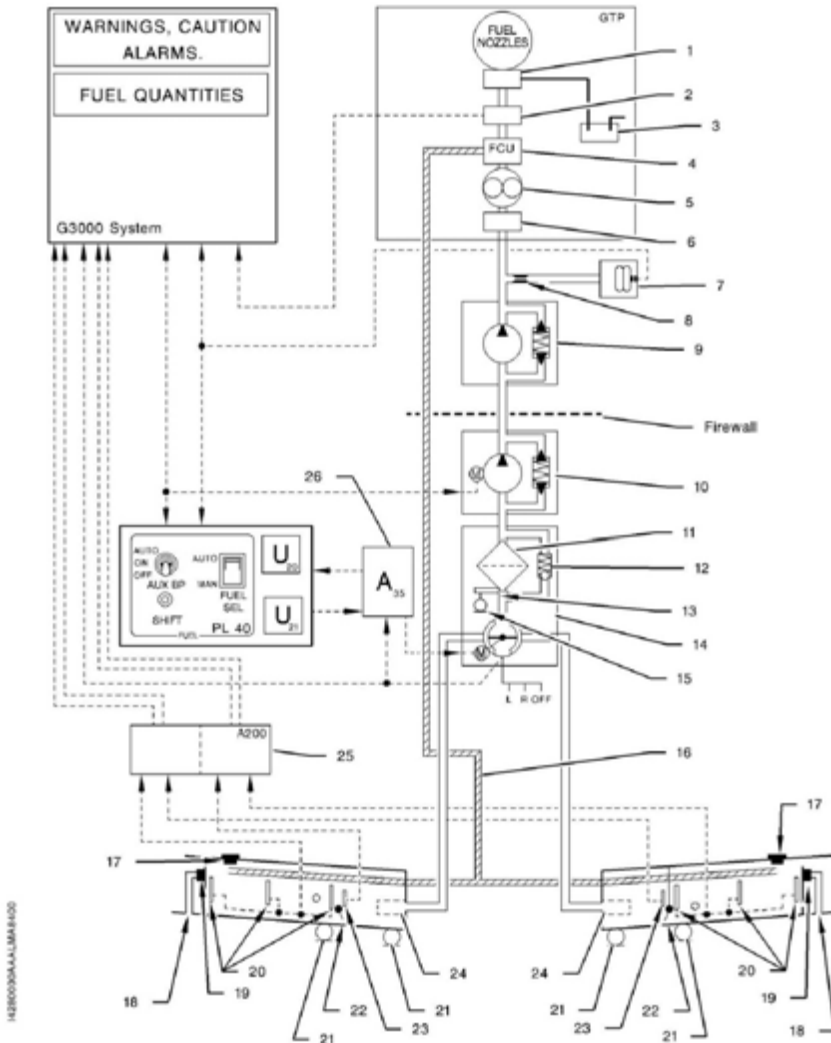

Figure 7.7.1 (2/2) - Fuel system

Automatic tank selector - see figures 7.7.2 and 7.7.3

Automatic tank selection allows, without pilot's intervention, feeding the engine from one tank or the other in predetermined sequences. These sequences depend on airplane configuration (ground, in-flight, fuel low level CAS messages appearance).

Automatic tank selection system comprises an electronic sequencer, an actuator attached on the fuel unit, FUEL SEL two-position selector (AUTO, MAN) and SHIFT push-knob located on FUEL panel.

To operate the automatic selector, set FUEL SEL switch to AUTO position and manual selector to R or L.

Selector operation

When the system is operated, **AUTO SEL** disappears ; the sequencer chooses a tank (R or L) and through the actuator, positions the fuel unit selector on the selected tank. The sequencer controls the time during which the selected tank will operate. This time varies, depending on airplane conditions.

Airplane on ground : tank is changed every minute and 15 seconds.

Airplane in flight : tank is changed every five minutes, as long as **FUEL LOW L** or **FUEL LOW R** does not appear. When the first low level lights on, the sequencer immediately selects the other tank. The selected tank will operate until the second low level lights on. When **FUEL LOW L-R** is visible, the sequencer changes tanks every minute and 15 seconds.

• NOTE •

The manual selector is driven by the fuel unit and is positioned on R or L mark corresponding to the tank selected by the sequencer. Therefore, the pilot continuously knows the tank which is operating.

•

Test for system proper operation

SHIFT push-button allows the pilot to test system proper operation anytime.

When the system operates, the fuel tank is changed when SHIFT push-button is pressed once.

If airplane is on ground or in flight, low level CAS messages not visible, the new selected tank remains operating and a new sequence is initiated.

• NOTE •

This procedure allows the pilot to preferably choose the tank from which he/she wants to take fuel.

In all cases, proper system operation is indicated by rotation of the manual selector. Setting FUEL SEL switch to MAN position or setting FUEL TANK SELECTOR to OFF position leads to system de-activating and appearance of **AUTO SEL**.

AUTO SEL also lights on when order given by the sequencer has not been executed after 12 seconds.

Electric boost pump (AUX BP)

Electric boost pump is an auxiliary pump located between fuel unit and main mechanical boost pump. It is controlled through AUX BP switch located on FUEL panel. This switch allows stopping or selecting the two pump operating modes :

- when set to ON, electric boost pump operates permanently
- when set to AUTO, electric boost pump is automatically operated in case of fuel pressure drop at the mechanical boost pump outlet.



Figure 7.7.2 - Manual selector of fuel tanks

- 1) AUX BP switch
- 2) FUEL SEL switch
- 3) SHIFT push-button

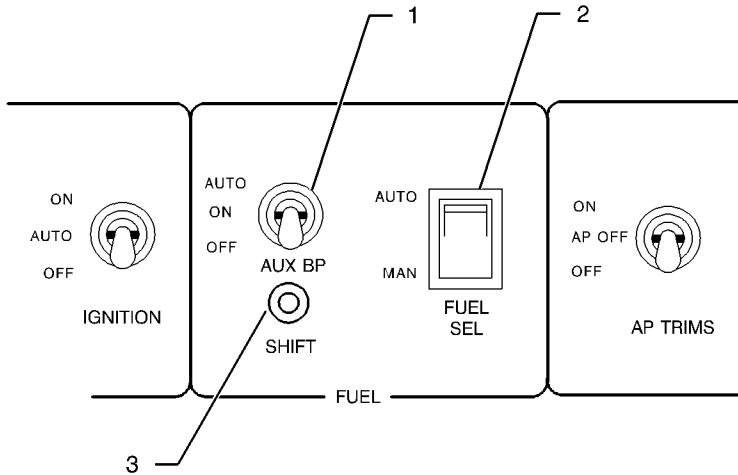
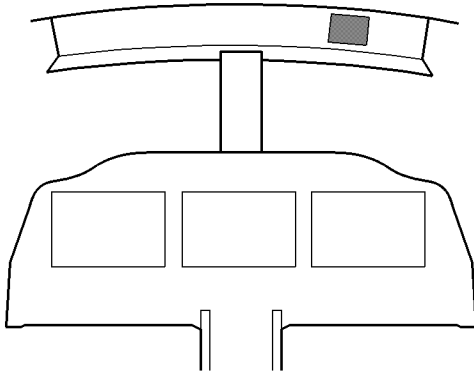

1424000AAA XMA8001

Figure 7.7.3 - Fuel control panel

Main mechanical boost pump

The mechanical boost pump is attached to accessory gearbox and supplies fuel necessary for engine operation.

Engine fuel system

The engine fuel system consists of a fuel regulator, pumps, filters, a fuel divider and fuel nozzles. The system provides the fuel flow necessary to satisfy the engine power and rating needs.

The fuel coming from airplane system goes through a heater which is automatically controlled by a thermostatic valve.

Fuel gaging installation

Fuel quantity is measured using capacitive-type sensors. Fuel quantity is displayed in US gallons. Three fuel level gauges are installed in each tank. The wing root side fuel level gauge is equipped with a low level detector which leads to fuel low level CAS messages appearance, when usable fuel quantity remaining in the concerned fuel tank is under about 9 USG (34 Litres).

Fuel system monitoring

Fuel system monitoring is ensured by CAS messages :

- **FUEL OFF** : Fuel tank selector set to OFF
- **FUEL PRESS** : Fuel pressure at mechanical boost pump outlet under 10 psi (\pm 2 psi)
- **AUX BOOST PMP ON** : Electric fuel boost pump running (manual or automatic mode)
- **FUEL LOW L-R** * : Fuel quantity less than or equal to 9 USG (34 Litres) of usable fuel in specified tank
- **AUTO SEL** : Fuel sequencer is inactive or a fault occurred
- **FUEL IMBALANCE** : Fuel tanks imbalanced by more than 15 USG (57 Litres) for more than 30 seconds

* Only affected side (L, R or L-R) displayed in CAS message

Fuel system draining and clogging indicator - see figure 7.7.4

The fuel system comprises five drain points, a drain on the filter bowl, two drain valves on each tank, located on wing lower surface, one at wing root and the other past main landing gear well.

These drains allow draining water or sediments contained in fuel.

Fuel tank drain valves are provided with a slot which allows opening them with a screwdriver.

▲ CAUTION ▲

Fuel system draining shall be performed prior to the first flight of the day and after each tank refueling, using a sampler to pick off fuel at the two drain valves of each tank and at the filter vent valve.



A red filter bypass flag on the fuel unit and visible from outside, when an inspection door located on L.H. side under front baggage compartment is open, indicates filter clogging. A push-button, adjacent to the inspection door, controls the illumination of a light provided to improve visibility of the clogging indicator. This indicator shall be observed during preflight inspection.

● NOTE ●

When filter gets clogged in flight, the filter is by-passed in order not to deprive powerplant from fuel. The powerplant is then supplied with non-filtered fuel.



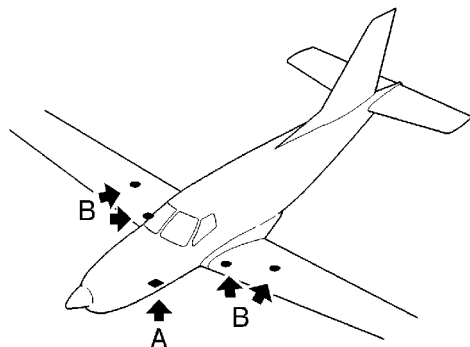

- 1) Lighting switch
- 2) Mirror door
- 3) Clogging indicator
- 4) Central access door
- 5) Filter drain
- 6) Tank drain
- 7) Drain bowl

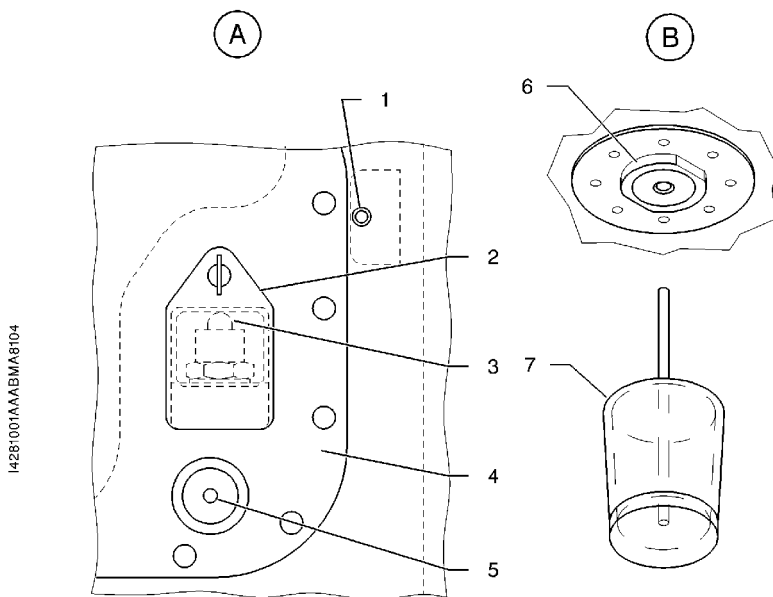

Figure 7.7.4 - Fuel system draining points and clogging indicator

7.8 - Electrical system - see figures 7.8.1, 7.8.2 and 7.8.5

The airplane is fitted with a 28-volt direct-current electrical system.

Electrical supply is obtained from various power supplies :

- a starter generator
- a stand-by generator
- a battery
- a ground power unit, via a plug, located on L.H. side.

Connection relays, main bus bar, generator regulation and protection systems and control logic systems are grouped in electrical power system box located in front baggage compartment upper section.

Electrical system indicating is displayed on the MFD and monitoring is ensured by CAS messages.

On ground, when the crash lever is positioned in the UP position (SOURCE selector in the OFF position), the battery supplies the electrical power system through the BATT BUS. A Power Up Built In Test (P-BIT) of the EPS internal functions is performed to verify the operating status. In case of failure detection, a white message EPS SERVICE REQUIRED appears in the message window on the PFD.

Starter generator

The starter generator is the main electrical power source. It only performs its generator function when starting sequence is completed.

Generator connection with main bus bar is controlled through GENERATOR selector set to MAIN position. It will be effective when connection conditions are met.

Generator connection is indicated by **MAIN GEN** disappearance.

• NOTE •

Starter generator will not supply airplane if source switch is on GPU.

On ground, generator load should be maintained below 200 AMP.

•

Stand-by generator

Stand-by generator supplies a 28-volt stand-by direct current which may be used in case of main generator failure.

Generator connection with main bus bar is controlled through GENERATOR selector set to ST-BY, it will be effective when connection conditions are met.

• NOTE •

Stand-by generator will not supply airplane if source switch is on GPU.

In order to prevent possible errors during flight, access to ST-BY position requires a double action from the pilot (pull to unlock). On ground, avoid using stand-by generator at full load.

•

Battery

The battery provides the power required for starting when no ground power unit is available and is a power supply source when engine driven generators are stopped.

The battery is always connected to BATT BUS bus bar except when crash lever is pulled down.

Battery connection to main bus bar is controlled through SOURCE selector set to BATT position.

BAT OFF lights on when battery is isolated from the main bus and when main bus is supplied through another source.

Ground power receptacle

The ground power receptacle allows connection to a ground power unit.

Ground power receptacle connection with main bus bar is controlled through SOURCE selector when set to GPU position, it will be effective when connection conditions are met.

When SOURCE selector is set to GPU position, the battery and ground power unit are connected simultaneously on main bus bar.

Ground power receptacle door opening is indicated by **GPU DOOR** appearance.

● NOTE ●

Before connecting a GPU to the airplane, ensure that the voltage of the GPU is regulated between 27.5 volts and 28.5 volts.

The amperage output needs to be consistent with the airplane placard in front of compartment door : GPU shall provide a current limiting function, and current limit shall be set per placard.

Do not use batteries pack as GPU sources.



▲ CAUTION ▲

Use of a ground power source with voltage in excess of 28.5 volts or current exceeding current limit indicated on placard may damage the airplane electrical system.



Distribution

Airplane electrical systems are connected to bus bars and protected by pull-off type breakers located on R.H. side panel - see figure 7.8.4. In case of overload of a system, the breaker triggers and switches the system off.

▲ CAUTION ▲

If a breaker corresponding to a non essential system trips, do not reset in flight.



If a breaker corresponding to an essential system trips:

- allow it to cool for about three minutes, then the breaker may be reengaged (pressed down)
- if the breaker trips again, do not reset.

BUS 1, BUS 2, BUS 3 and BUS 4 bus bars are directly connected to main bus bar and protected by fuses located in electrical power system.

The ESS BUS 1 and ESS BUS 2 essential bus bars are connected to main bus bar through ESS BUS TIE switch set to NORM position. ESS BUS TIE switch is attached to breaker panel ; NORM position is protected and locked by a cover. Common power supply to both essential bus bars is protected by a fuse, located in EPS box, and a breaker, located in the front cargo compartment on C2 frame right side, each bar being individually protected by a breaker.

BATT BUS bar is directly connected to the battery ; it is protected by a fuse, located in EPS box, and a breaker, located in the front cargo compartment on C2 frame left side.

● NOTE ●

The electrical distribution of bus bars is described in figure 7.8.3.



Emergency use

With both generators de-activated in flight, it is still possible to use battery power to supply all airplane systems maintaining SOURCE selector on BATT position.

In order to save battery power, it is possible to shed the charges which are not essential for flight safety, for that set :

- ESS BUS TIE switch to EMER position

In this configuration, only ESS BUS 1, ESS BUS 2 and BATT BUS bars are supplied.

● NOTE ●

Supplying BUS 1, BUS 2, BUS 3 and BUS 4 bars is always possible, resetting temporarily ESS BUS TIE switch to NORM position.



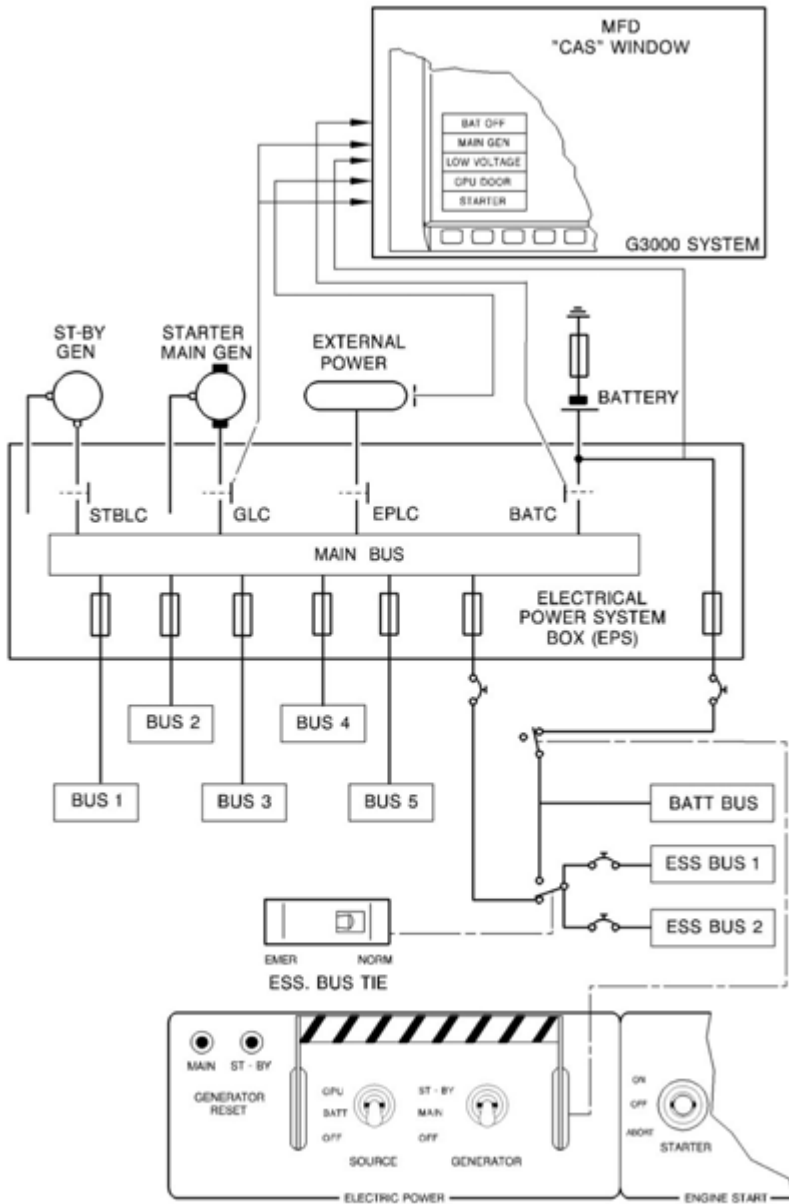

14240000AAA1HMA8300

Figure 7.8.1 - Electrical diagram

Switches				Buses are powered by				
Crash lever	Source	Generator	ESS BUS TIE	BATT BUS	ESS BUS 1	ESS BUS 2	BUS 1 TO 5	
UP	BATT	OFF	NORM	Battery	Battery	Battery	Battery	
UP	BATT	MAIN	NORM	Battery & MAIN	Battery & MAIN	Battery & MAIN	Battery & MAIN	(*)
UP	BATT	ST-BY	NORM	Battery & ST-BY	Battery & ST-BY	Battery & ST-BY	Battery & ST-BY	(*)
UP	OFF	MAIN	NORM	MAIN	MAIN	MAIN	MAIN	
UP	OFF	ST-BY	NORM	ST-BY	ST-BY	ST-BY	ST-BY	
UP	BATT	OFF	EMER	Battery	Battery	Battery	None	

(*) In that case, power is done by MAIN or ST-BY and battery is used as a floated battery.

Figure 7.8.2 - Bus bars supply configurations

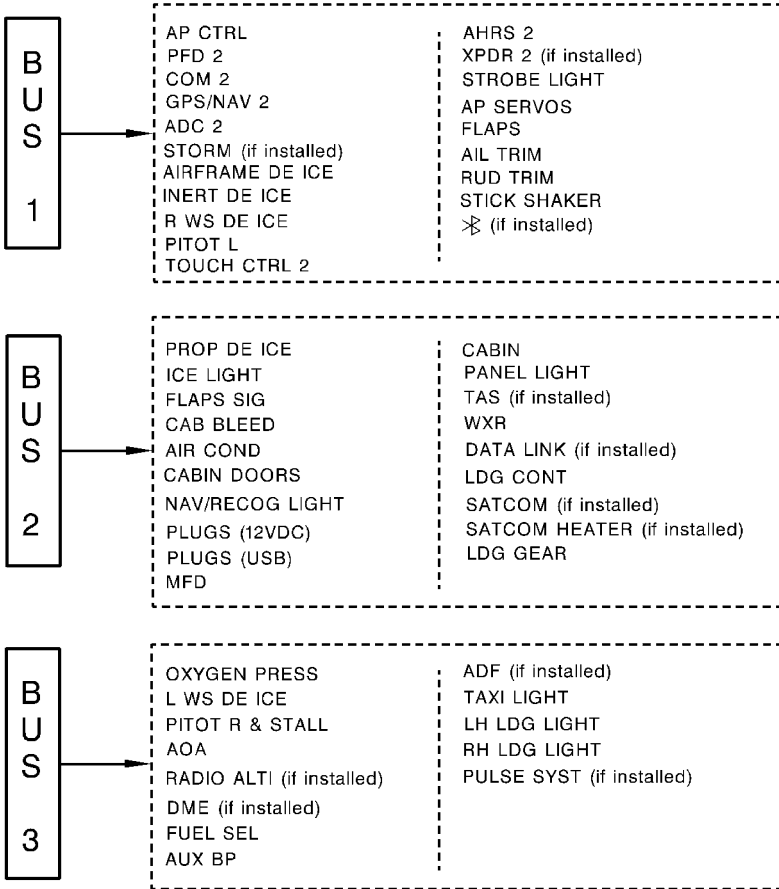

14246000AAANNMA8400

Figure 7.8.3 - (1/3) - Electrical distribution of bus bars

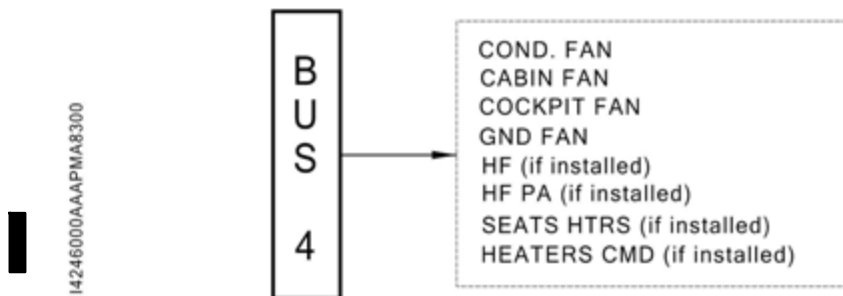

NOTE : BREAKERS ON C13 BIS FRAME

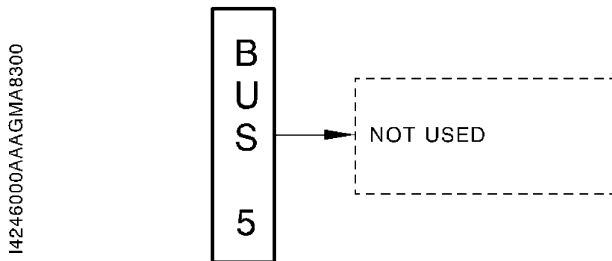
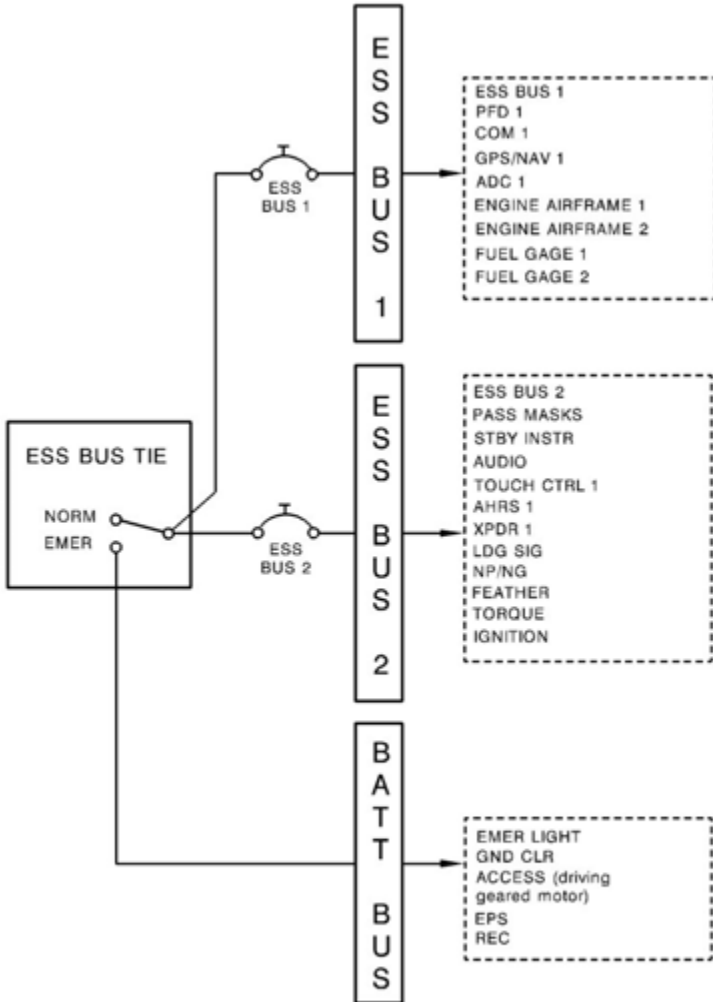

Figure 7.8.3 (2/3) - Electrical distribution of bus bars



14246000AAJGMA18200

Figure 7.8.3 (3/3) - Electrical distribution of bus bars

ESS BUS TIE	Essential bus NORM & EMER switch
BUS 1	
AP SERVOS	Autopilot servo protection
FLAPS	Flaps protection
AIL TRIM	Aileron trim protection
RUD TRIM	Pitch trim protection
BUS 2	
LDG GEAR	Landing gear general supply protection
ESS BUS 1	
ESS BUS 1	Essential bus 1 circuit protection
PFD 1	Primary Flight Display 1 protection
COM 1	VHF 1 protection
GPS/NAV 1	GPS NAV 1 protection
ADC 1	Air Data Computer 1 protection
ENGINE	Powerplant cont. protec. : Oil temp. & pres., torque, propeller
AIRFRAME 1	
ENGINE	Powerplant cont. protection : Ng, flowmeter & ITT
AIRFRAME 2	
FUEL GAGE 1	L.H. fuel gage protection
FUEL GAGE 2	R.H fuel gage protection
ESS BUS 2	
ESS BUS 2	Essential bus 2 circuit protection
PASS MASKS	Passengers' oxygen masks protection
STBY INSTR	Standby Attitude Module (MD302) protection
AUDIO	Audio control panel protection
TOUCH CTRL 1	Touchscreen controller 1 protection
AHRS 1	Attitude and Heading Reference System 1 protection
XPDR 1	Transponder 1 protection
LDG SIG	Landing gear indicating system protection
NP/NG	Tachometer signal conditioner protection
FEATHER	Propeller feather protection
TORQUE	Torque control protection
IGNITION	Powerplant ignition protection
(Cont'd on next page)	

Figure 7.8.4 (1/5) - Breaker panel (Typical arrangement)

BUS 1	
AP CTRL	Flight controller protection
PFD 2	Primary Flight Display 2 protection
COM 2	VHF 2 & radio protection
GPS/NAV 2	GPS NAV 2 protection
ADC 2	Air Data Computer 2 protection
STORM	Stormscope protection, if installed
AIRFRAME DE ICE	Empennage and wing leading edges deicing
INERT DE ICE	Inertial separator protection
R WS DE ICE	R.H. windshield deicing protection
PITOT L	Pitot L heating protection
TOUCH CTRL 2	Touchscreen controller 2 protection
AHRS 2	Attitude and Heading Reference System 2 protection
XPDR 2	Transponder 2, if installed protection
STROBE LIGHT	Strobe lights protection
SHAKER	Stick shaker protection
BUS 2	
PROP DE ICE	Propeller deicing protection
ICE LIGHT	L.H. wing leading edge lighting and lighting test protection
FLAPS SIG	Trim and flaps regulator protection
CAB BLEED	Cabin pressurization protection
AIR COND	Cabin ventilation and vapor cycle system protection
CABIN DOORS	Cabin doors opening protection
NAV/RECOG LIGHT	Navigation and recognition lights protection
PLUGS	12 VDC plugs protection
PLUGS	USB plugs protection
MFD	Multifunction display protection
CABIN	Passenger's reading lamps protection
PANEL LIGHT	Instruments lighting protection
TAS	TAS, if installed protection
WXR	Weather radar protection
DATA LINK	Data Link, if installed protection
LDG CONT	Landing gear control protection
(Cont'd on next page)	

Figure 7.8.4 (2/5) - Breaker panel (Typical arrangement)

BUS 2 (Cont'd)	
SATCOM	SATCOM protection, if installed
SATCOM HEATER	SATCOM heater protection, if installed
BUS 3	
OXYGEN PRESS	Oxygen/Pressure indication protection
L WS DE ICE	L.H. windshield deicing protection
PITOT R & STALL	Pitot R and stall warning heating protection
AOA	Angle of Attack protection
RADIO ALTI	RADIO ALTI, if installed protection
DME	DME protection, if installed
FUEL SEL	Tank selector timer protection
AUX BP	Electrical fuel pump protection
ADF	ADF protection, if installed
TAXI LIGHT	Taxi light protection
LH LDG LIGHT	L.H. landing light protection
RH LDG LIGHT	R.H. landing light protection
PULSE SYST	Pulse lite system protection, if installed
BATT BUS	
EMER LIGHT	Instrument panel emergency lighting protection
GND CLR	Ground clearance protection
ACCESS	Cabin access lighting protection
EPS	Electrical power system protection
REC	Lightweight Data Recorder protection

Figure 7.8.4 (3/5) - Breaker panel (Typical arrangement)

>> Up to S/N 1159

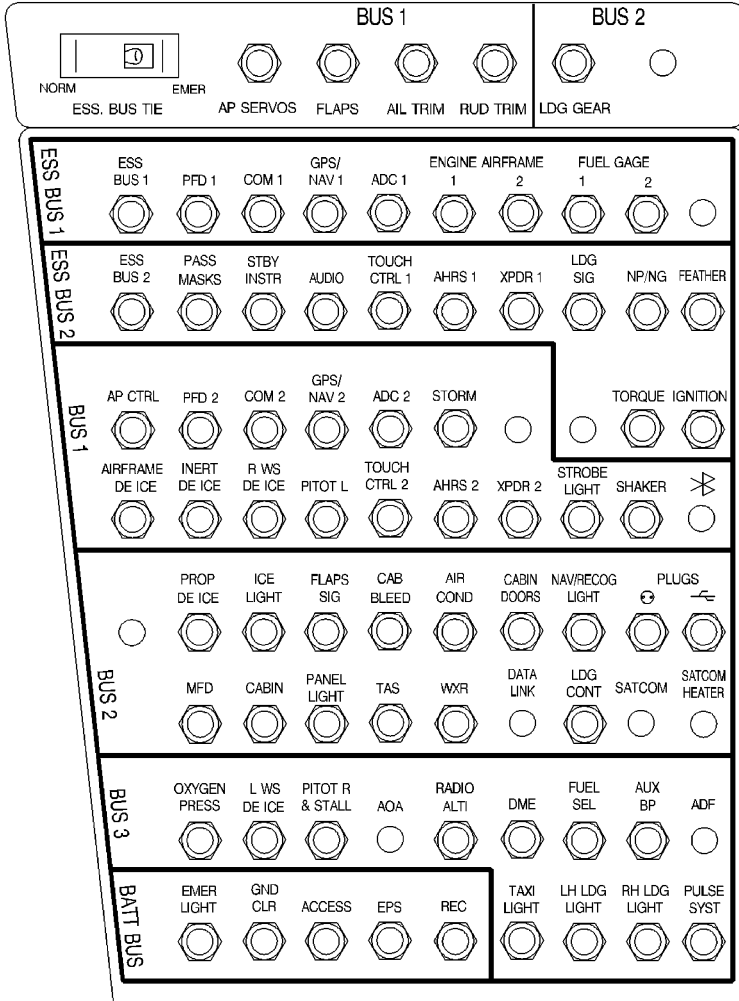

I4255004AAAPMA8002

Figure 7.8.4 (4/5) - Breaker panel (Typical arrangement)

■ >> From S/N 1160

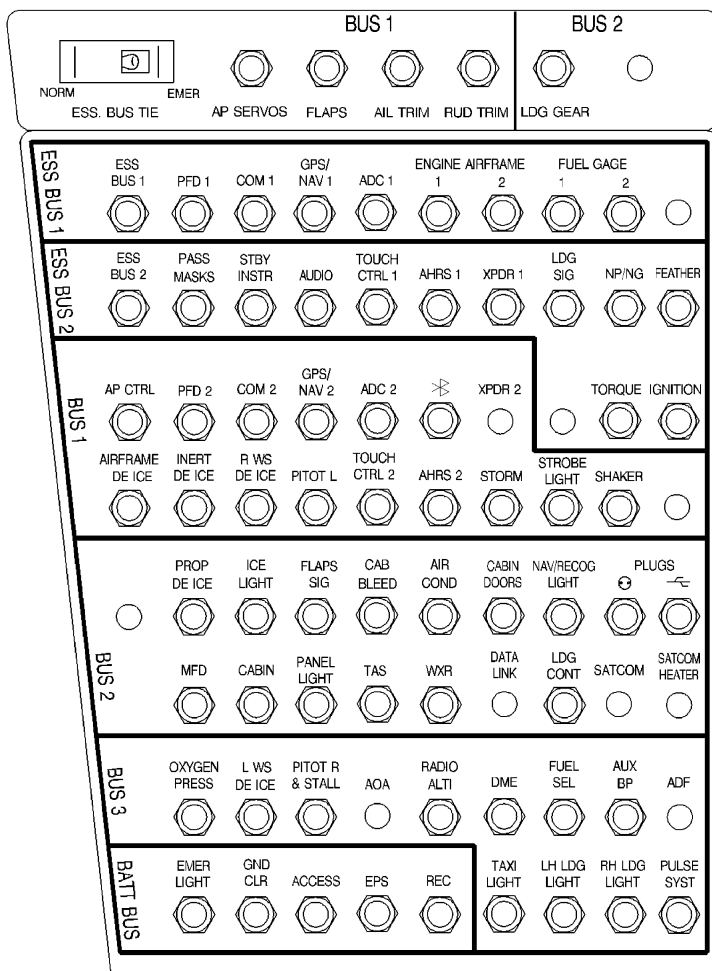

14255004AAAPMA18200

Figure 7.8.4 (5/5) - Breaker panel (Typical arrangement)

■ >> All

Indicating

Electrical system indicating consists of voltage and ampere indicating - refer to GARMIN Pilot's Guide for further details.

Following CAS messages may appear on the MFD CAS window :

BAT OFF

: Battery is not connected to main bus bar

MAIN GEN

: Starter generator is not connected to main bus bar

LOW VOLTAGE

: Battery voltage is below the minimum value

GPU DOOR

: Ground power receptacle access door is not closed

Protection - safety - see figures 7.8.2 and 7.8.5

The electrical power system provides systems protection in case of :

- overvoltage
- short-circuits

In case of disconnection of starter generator or stand-by generator following a failure, MAIN or ST-BY reset can be done by pressing corresponding GENERATOR RESET MAIN or ST-BY push-button.

A battery reset is done by setting the SOURCE selector to OFF and back to BATT.

In case of disconnection of ground power unit following a failure, it is possible to re-activate the system by turning the SOURCE selector to OFF and setting it again to GPU position to reset the protection.

A crash lever located on upper panel center part allows isolating simultaneously BATT BUS bar and setting to OFF the SOURCE and GENERATOR selectors when lowered. In this case all bus bars are isolated from generators.

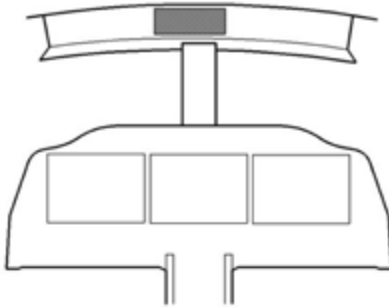

- 1) MAIN reset knob
- 2) ST-BY reset knob
- 3) Crash lever
- 4) SOURCE selector
- 5) GENERATOR selector

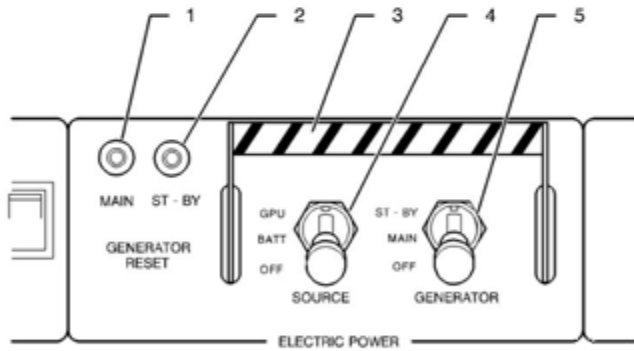

142-0000AAUUA8300

Figure 7.8.5 - Electrical control

Exterior lighting - see figure 7.8.6

The airplane is equipped with three strobe and navigation lights, two landing lights, two taxi lights, two recognition lights and a wing leading edge icing inspection light.

Landing lights

The landing lights are embedded in the winglets' leading edge. These lights are controlled by setting a switch located on upper panel to LDG.

The Pulse lite system, if installed, allows the pilot to have the landing lights flash continuously, making the airplane more visible to the control tower and to nearby aircraft.

Taxi lights

The taxi lights are embedded in the winglets' leading edge. These lights are controlled by setting a switch located on upper panel to TAXI.

Navigation lights and strobe lights

Two strobe and navigation lights are installed in the winglets and one on the tail cone. They are controlled by NAV and STROBE switches located on upper panel.

• NOTE •

At night, do not use anti-collision lights in fog, clouds, or mist - as reflection of the flashing lights may lead to dizziness and disorientation.

•

Recognition lights

Recognition lights are embedded in the winglets.

They are automatically switched on when the airplane is on ground.

Leading edge icing inspection light

The leading edge icing inspection light is installed on the left side of the fuselage and illuminates the wing leading edge. This light is controlled by the ICE LIGHT switch installed on DE ICE SYSTEM panel - see figure 7.13.1.

FWD compartment light

The dome light illumination of the FWD compartment is controlled by the switch located in the upper section of the door frame.

Fuel unit compartment light

The lighting of the fuel unit compartment allows improving the visibility of the clogging indicator by pressing the push-button located besides the inspection door.

- 1) Taxi and landing light switch
- 2) Pulselite system switch
- 3) Navigation lights switch
- 4) Strobe lights switch

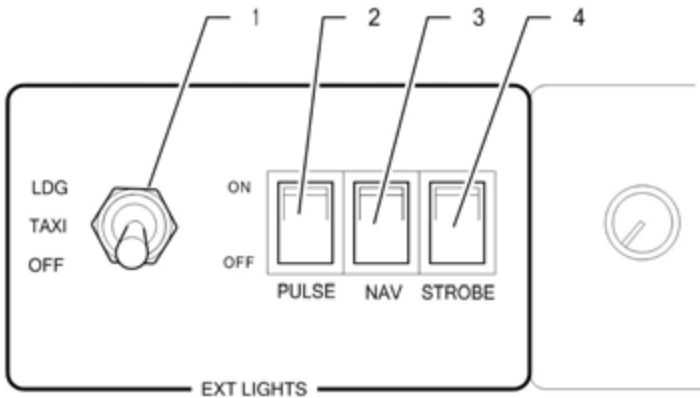
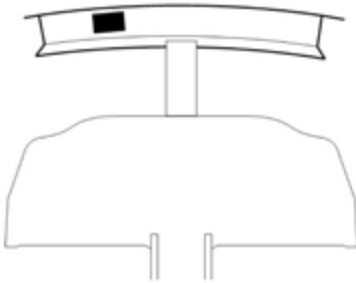

OR

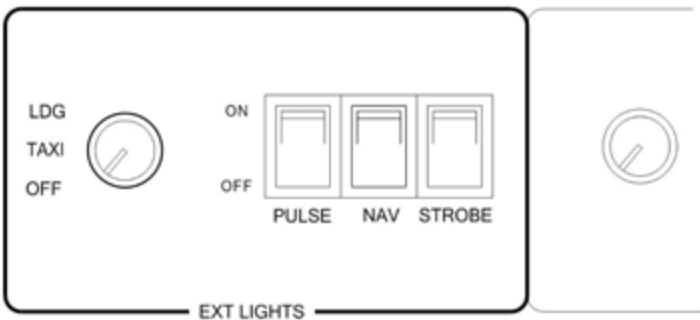

1424000AAAAYMAS302

Figure 7.8.6 - External lighting controls

Interior lighting - see Figure 7.8.7

Interior lighting consists of access, cabin, instrument panel, instruments, baggage compartment and emergency lighting.

Access lighting

Access lighting consists of two floodlights located on the ceiling upholstery (one at the level of the access door, the other at the level of the storage cabinet) and the L.H. dome light of baggage compartment. ACCESS push-button on INT LIGHTS panel and the push-button located on access door rear frame control these 3 lights via a delayed breaker.

If the crash lever is down, access lighting is automatically cut out after 3 minutes.

If the crash lever is up, there is no access lighting automatic cut out.

Cabin lighting

Cabin lighting consists of two individual floodlights for front seats, six individual floodlights for rear passenger seats and the baggage compartment R.H. dome light. Each floodlight is controlled by a push-button located near. The pilot can switch off the cabin floodlights and the baggage compartment dome light with the CABIN switch.

Instrument panel lighting

Instrument panel lighting is controlled by the PANEL rheostat located on INT LIGHTS panel. This lighting consists of backlighted panels and a led lighting for the pedestal.

Breaker panel lighting

Breaker panel lighting is controlled by a switch located on the instrument panel near the pilot's control wheel.

Emergency lighting

Emergency lighting consists of two swiveling floodlights located on both sides of the cockpit overhead panel above front seats. It illuminates instrument panel assembly in case of visor lighting tubes and / or instrument integrated lighting failure.

A rheostat located on the cockpit overhead panel controls emergency lighting operation and intensity. Forward rotation of control knob allows changing from OFF position to minimum lighting then increasing lighting to maximum brightness.

- 1) Instrument panel lighting switch (rheostat)
- 2) DIMMER switch
- 3) Cabin lighting switch (rear seats reading light)
- 4) Access door, baggage compartment and FWD dome light (delayed breaker) push-button
- 5) Emergency lighting switch
- 6) Breaker panel lighting switch

Figure 7.8.7 (1/2) - Internal lighting controls

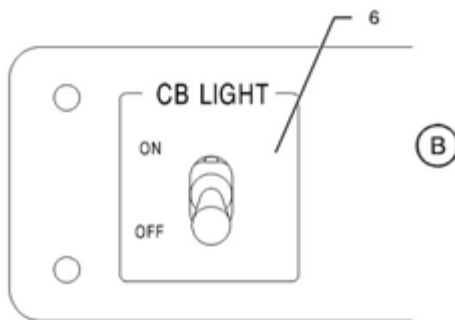
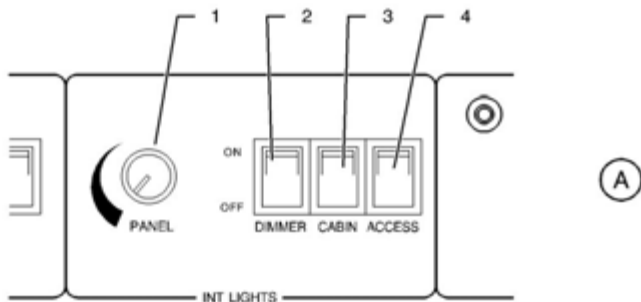
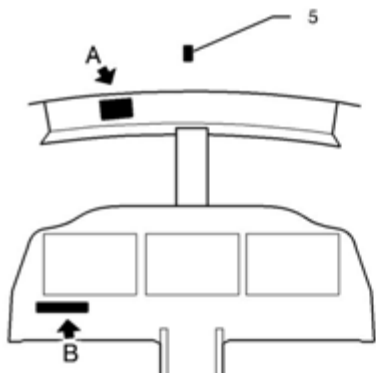

H2-40000-AAA/VMA/S200

Figure 7.8.7 (2/2) - Internal lighting controls

7.9 - Air conditioning and pressurization

• NOTE •

A list of abbreviations used in this chapter is given in figure 7.9.2.

•

The airplane is equipped with a Global Air System (GAS), which ensures air conditioning and pressurization control - see figure 7.9.2.

- Air conditioning corresponds to the cockpit / cabin air temperature management.
- Pressurization corresponds to the cabin altitude / rate of change management.

The GAS is composed of 3 sub-systems :

- engine bleed air system,
- cabin pressurization control system,
- dual-zone Environmental Control System, which includes heating and cooling functions.

These sub-systems are managed by a single digital controller, the GASC, which receives information from :

- the sensors within the sub-systems,
- the human interfaces integrated in the airplane.

The GASC sends commands to the sub-systems actuators and indication or warning elements.

GAS controls are located on :

- the A/C panel on the left side of the left control wheel,
- the PRESSURIZATION panel on the right side of the left control wheel,
- a control panel above the armrest of the left-side passenger seat.

The pilot monitors the system through information and CAS messages displayed on the MFD. These indications are independent of the GASC controls and internal sensors.

Engine bleed air system

The engine bleed air system is designed to ensure the following functions :

- to regulate the bleed air from the engine,
- to ensure a controlled airflow in the cabin,
- to adjust the bleed air temperature for cabin heating.

To regulate the bleed air from the engine

The engine bleed air system operates from either P2.5 or P3 engine bleed ports.

The system normally operates on the P2.5 port as long as the pressure or temperature demands are met by this port.

■ If one of these demands is not met, the system automatically switches to the P3 port.

When the pressure or temperature demand can be met by the P2.5 port, the system automatically returns to using the P2.5 port.

■ The Inlet Pressure Port Sensor (IPPS) measures the pressure at the P2.5 port and sends this value to the GASC. The GASC controls the Shut Off Valve (SOV) switching function depending on the value received. The SOV switches from P2.5 to P3 and the BLEED HI message is then displayed.

A Non Return Valve (NRV) prevents P3 air from entering the P2.5 port when the P3 port is opened.

To ensure a controlled airflow in the cabin

The bleed air flow is controlled by the Flow Control and Shut Off Valve (FCSOV) driven by the GASC.

To adjust the temperature of the bleed air

The bleed air outlet temperature control is ensured by the By-Pass Valve (BPV) in association with the Main Heat Exchanger (MHX).

■ Based on pilot's or passengers' TEMP selector position, the GASC computes the appropriate cabin air inlet temperature target and compares it to the actual measured inlet temperature in order to set the BPV position. The BPV diverts the required amount of bleed air through the MHX in order to mix it with cabin air, and then provides air at the cabin Inlet Temperature Sensor (ITS) target.

System operation

See figure 7.9.3.

The BLEED switch allows selection of the engine bleed air system, provided that the engine is running.

The Ground Fan (GF) operates until takeoff, when BLEED switch is set to AUTO, and **MAIN GEN** is OFF.

The BLEED switch is fitted with a blocking device between the AUTO, MAX DIFF and OFF positions. This prevents the operator from inadvertently setting the BLEED switch to the OFF position.

To reset the system, set BLEED switch to OFF, then back to AUTO.

System protection

Power for the engine bleed air system is supplied by the BUS 2 bar and is protected by the CAB BLEED breaker.

Cabin pressurization control system

In flight, the GASC controls the modulation of the Outflow Valve (OFV) in order to reach the computed cabin altitude.

System operation

See figure 7.9.3.

The BLEED switch activates the pressurization system.

Either one of two pressurization modes can be selected : AUTO or MAX DIFF

- When BLEED switch is set to AUTO, the GASC controls the cabin altitude rate of change in order to :
 - . optimize comfort,
 - . avoid reaching maximum or negative cabin differential pressure.
- MAX DIFF mode controls the cabin pressure to assist passengers that might require the lowest cabin altitude possible. When selecting this mode :
 - . flights below 13500 ft will result in cabin altitudes as low as 0 ft,
 - . for flights above 13500 ft, the cabin altitude is minimized throughout the flight while maintaining cabin differential pressure below 6.0 PSI.

The GASC controls the OFV through a torque motor on the valve.

Cabin altitude management

To maximize comfort during all phases of flight, the cabin altitude is automatically computed by the GASC using flight parameters (such as airplane altitude, altitude rate of change) provided by the avionics.

During descent, the GASC uses the Landing Field Elevation (LFE) to manage the optimal cabin altitude rate of change so that the airplane lands with a cabin altitude equal to LFE minus 200 ft.

The pilot selects LFE on the touchscreen controller :

- automatically, by setting a destination airport in the flight plan,
- manually, by pressing "MFD Home," "Aircraft Systems," "Landing Field Elev" and then "Manual."

System monitoring

The pilot monitors the pressurization system through information displayed on the MFD :

- landing field altitude in ft,
- cabin altitude in ft,
- cabin climb speed in ft/min,
- cabin differential pressure (ΔP) in PSI.

These indications are independent of the GASC controls and internal sensors.

I4213000AAVMA8000



Figure 7.9.1 - Cabin altitude monitoring

CAS messages are displayed in the MFD CAS window :

- **PRESSU OFF** indicates that the BLEED switch is in the OFF position, or that the Flow Control and Shut Off Valve (FCSOV) is closed due to a system malfunction (cabin inlet overtemperature, BDPS or FCSOV failure).
- **CABIN ALTITUDE** indicates that the cabin altitude is over 10000 ft.
- **CABIN DIFF PRESS** indicates that the cabin differential pressure is over 6.4 psi (441 mb). The DUMP switch could be used in case of necessity to depressurize the cabin.
- **PRESSU BACKUP** indicates that the GASC is unable to compute optimal cabin altitude due to a system malfunction. In this condition, the GASC will control the cabin altitude to a default value of 9800 ft.
- **GAS DEGRADED** indicates that the pressurization system is degraded without total loss of pressurization, or that the heating system is degraded.
- **GAS EVENT** is displayed 45 seconds after landing if a fault on the Overheat Thermal Switch was detected by the GASC during flight.
- **MAX DIFF MODE** indicates that the BLEED switch is set to MAX DIFF.

Protection - Safety

As soon as the airplane is on the ground, the cabin is automatically depressurized through the activation of landing gear switches (airplane on ground), or - if necessary - by actuating the DUMP switch located on the PRESSURIZATION panel. In normal operation, this switch is protected and locked by a cover.

Overpressure and negative relief safety are managed by both the OFV and SFV. The safety functions are ensured by independent pneumatic modules fitted on both valves, which override the GASC control when necessary.

The DUMP switch allows the pilot to open the OFV in order to depressurize the cabin.

The OFV is fitted with a cabin altitude limitation device which overrides the DUMP function and forces the closure of the OFV if the cabin altitude reaches 14500 ft.

Dual-zone Environmental Control System (ECS)

The ECS controls both the cockpit and cabin heating and cooling functions.

The ECS consists of two independent air circuits :

- Heating circuit, controlled by the Temperature Conditioning System (TCS)
- Cooling circuit, controlled by the Vapor Cycle Cooling System (VCCS)

Heating circuit

The TCS regulates hot air coming from the bleed air system (also used for pressurization) and mixes it with the recirculating cabin air at the Mixing Ejector (MIXEJ) to lower the delivered air temperature.

The resultant air flow enters the Hot Air Distributor (HAD) and is distributed in the cockpit / cabin zones depending on the demand.

The air is distributed :

- into the cockpit zone through :
 - . ports located on pedestal sides,
 - . ports under each seat or
 - . the demisting outlets.
- into the cabin zone through :
 - . ports located on the lower section of the left-side and right-side cabin upholstery.

Cooling circuit

The VCCS is selected on only when the GASC receives a cooling command. It is composed of two independent circuits :

- one for the cockpit zone
- one for the cabin zone

For each circuit, the intake of air is by means of a variable speed electrical fan, with the air blown through an evaporator and ducted to the different zones :

- into the cockpit by passing through :
 - . the upper panel equipped with swiveling and adjustable air outlets,
 - . air outlets located on armrests of pilot and front passenger stations and
 - . ports located under instrument panel.

- into the cabin by passing through :
 - . the overhead duct equipped with swiveling and adjustable air outlets,
 - . ports located on the floor between the cabinets and the intermediate passenger seats.

System operation

See figure 7.9.3 and the paragraph : Air temperature management.

A/C control panel selection :

If the A/C switch is set to OFF :

>> *Before the GASC software update (Pre-MOD70-0689-21)*

- Temperature is set by default by the GASC to 23°C,

>> *After the GASC software update (Post-MOD70-0689-21)*

- The system maintains the previously-selected cabin air inlet temperature. The pilot can manage this temperature by using the TEMP selector on A/C panel,

>> *All*

- Cockpit / cabin evaporator fans are OFF,
- VCCS is inhibited.

If the A/C switch is set to PILOT :

- Controls located in the cabin zone are inhibited.

If the A/C switch is set to PLT+PAX :

- Each zone is controlled by its own settings.

Cockpit and cabin FAN speed selector positions :

- OFF : prevents air recirculation.
- 1 - 4 : Cockpit / cabin fan speeds are selectable.

Cockpit and cabin TEMP selectors :

- Enables temperature adjustments for the cockpit and cabin zones.

>> *After the GASC software update(Post-MOD70-0689-21)*

- If the pilot or passengers set the TEMP selector to the maximum heat position, the bleed air system automatically switches from the P2.5 to the P3 bleed port to increase the temperature and flow rate of the incoming bleed air. Except in the case of very cold environmental conditions, this switching is inhibited below 25000 ft.

>> *All*

HOT AIR FLOW distributor :

The HOT AIR FLOW distributor selects between windshield defog or cabin heating.

● NOTE ●

For maximum efficiency, the HOT AIR FLOW distributor should be set either in the defog position (fully turned to the left) or in the cabin position (fully turned to the right).

●

>> *After the GASC software update (Post-MOD70-0689-21)*

When the HOT AIR FLOW distributor is set in defog position (fully turned to the left), the bleed air system automatically switches from the P2.5 to the P3 bleed port to increase the temperature and flow rate of the incoming bleed air. Except in the case of very cold environmental conditions, this switching is inhibited below 25000 ft.

>> *All*

Emergency air system :

An emergency ventilation valve allows outside air to enter the cabin when the EMERGENCY RAM AIR control knob is pulled out. The EMERGENCY RAM AIR control knob is located under the right side of instrument panel, near the right control wheel.

- In the NORMAL position, the valve is closed and the control is locked.
- To open the emergency ventilation valve, press the locking button on the knob and pull out.

● NOTE ●

Reduce the cabin differential pressure to be able to pull out the EMERGENCY RAM AIR control knob. If necessary, depressurize the cabin.

●

System protection

Power for the ECS is supplied by the BUS 2 bar and is protected by the AIR COND breaker.

Four fans are supplied by BUS 4 bar and protected respectively by following breakers : COND FAN, CABIN FAN, COCKPIT FAN and GND FAN.

The system includes an automatic load shedding feature which :

- when **MAIN GEN** is ON :
 - . turns off the Ground Fan (GF),
 - . turns off the Condenser Fan (COND FAN),
 - . opens compressor clutch.
- during engine start :
 - . turns off the Vapor Cycle Cooling System (VCCS)

Air temperature management

Cockpit and cabin heating / cooling

Cockpit and cabin air temperature management is operated by selecting :



For optimal air temperature management, select :



Air temperature expectations		Cockpit panel selection		Cabin panel selection	
Cockpit area	Warm				
Cabin area	Hot				

Results









Mixed Bleed Air Circuit :









Warm air is distributed to both the cockpit and cabin. More warm air is directed to the cabin due to the greater temperature demand.

Cold Air Circuit :

Not active, as no TEMP selector is set in the blue arc.

FANS select 0. Selecting a FAN speed will reduce cabin air temperature.

Air temperature expectations		Cockpit panel selection		Cabin panel selection	
Cockpit area	Warm				
Cabin area	Warm				
<p><u>Results</u></p> <p><u>Mixed Bleed Air Circuit</u> :</p> <p>Warm air is distributed to both the cockpit and cabin equally due to equal temperature demand.</p> <p><u>Cold Air Circuit</u> :</p> <p>Not active, as no TEMP selector is set in the blue arc.</p> <p><u>FANS</u> select 0. Selecting a FAN speed will reduce cabin air temperature.</p>					
Cockpit area	Warm				
Cabin area	Cool				
<p><u>Results</u></p> <p><u>Mixed Bleed Air Circuit</u> :</p> <p>Warm air is distributed to both the cockpit and cabin. More warm air is directed to the cockpit due to the greater temperature demand.</p> <p><u>Cold Air Circuit</u> :</p> <p>The cabin TEMP selector is set in the blue arc, resulting in the cabin air conditioning system supplying the cabin area.</p> <p><u>Cockpit FAN</u> : select 0.</p> <p><u>Cabin FAN</u> : select 1 or more to circulate the cooled air.</p>					

Air temperature expectations		Cockpit panel selection		Cabin panel selection	
Cockpit area	Cool				
Cabin area	Cool				
<p><u>Results</u></p> <p><u>Mixed Bleed Air Circuit :</u></p> <p>With the cockpit and cabin TEMP selectors set in the blue arc, the Hot Air Distributor discharges the mixed bleed air below the floor towards the cold air circuit fans and evaporators to adjust the air to the desired temperature.</p> <p><u>Cold Air Circuit :</u></p> <p>Both the cockpit and cabin TEMP selectors are set in the blue arc, resulting in both the cockpit and cabin air conditioning systems supplying their respective areas.</p> <p><u>Cockpit and cabin FANS :</u></p> <p>Select 1 or more to circulate the cooled air.</p>					
Cockpit area	Cool				
Cabin area	Warm				
<p><u>Results</u></p> <p><u>Mixed Bleed Air Circuit :</u></p> <p>Warm air is distributed to both the cockpit and cabin. More warm air is directed to the cabin due to the greater temperature demand.</p> <p><u>Cold Air Circuit :</u></p> <p>The cockpit TEMP selector is set in the blue arc, resulting in the cockpit air conditioning system supplying the cockpit area.</p> <p><u>Cockpit FAN :</u> select 1 or more to circulate the cooled air.</p> <p><u>Cabin FAN :</u> select 0.</p>					

● NOTE ●

FANS selected to zero ensures that no cool air is recirculated when trying to maximize the heating of the cockpit and / or cabin zones.

Pilot's Operating Handbook

Cabin override

- Setting the switch to the PILOT position disables TEMP and FAN speed selectors in the cabin area.

The PILOT position also distributes warm air equally to the cockpit and cabin.

Only the cockpit TEMP and FAN selectors inputs are used by the GASC for air temperature management.



Air temperature expectations		Cockpit panel selection		Cabin panel selection	
Cockpit area	Warm				
Cabin area	/				

Results





Mixed Bleed Air Circuit :

- Warm air is distributed equally to both the cockpit and cabin. The temperature is selected by the cockpit TEMP selector.

Cold Air Circuit :

- Not active, as the cockpit TEMP selector is set in the red zone and the cabin TEMP selector is inhibited.

Cockpit FAN : select 0. Selecting a FAN speed will reduce cabin air temperature.

Air temperature expectations		Cockpit panel selection		Cabin panel selection	
Cockpit area	Cool				
Cabin area	/				

Results

Mixed Bleed Air Circuit :

With the cockpit TEMP selector set in the blue arc, the Hot Air Distributor discharges the mixed bleed air below the floor towards the cold air circuit fans and evaporators to adjust the air to the desired temperature.

Cold Air Circuit :

The cockpit TEMP selector is set in the blue arc, resulting in both the cockpit and cabin air conditioning systems supplying their respective areas.

Cockpit FAN : select 1 or more to circulate the cooled air.

Cockpit FAN speed selector determines cabin FAN speed.

Windshield DEFOG

Windshield defog is operated by selecting :



or



Air temperature expectations		Cockpit panel selection		Cabin panel selection	
Cockpit area	/				
Cabin area	/				

Results

Mixed Bleed Air Circuit :

Air is distributed to the windshields and cockpit side windows at a fixed temperature regardless of TEMP selector settings.

Cold Air Circuit :

Inhibited when DEFOG is selected.

FANS will continue to operate if selected to 1 or more for air circulation.

Intentionally left blank

- 1) Demisting outlets
- 2) Front vents
- 3) Cockpit ventilated temperature sensor (CKVTS)
- 4) Cabin ventilated temperature sensor (CBVTS)
- 5) Air ports
- 6) Cabin control panel
- 7) Global air system controller (GASC)
- 8) Out-flow valve (OFV)
- 9) Safety valve (SFV)
- 10) Condenser fan
- 11) Condenser
- 12) High pressure switch
- 13) Drier filter
- 14) Cabin fan
- 15) Cabin evaporator
- 16) Cabin blown temperature sensor (CBBTS)
- 17) Cabin thermostatic valve
- 18) Low pressure switch
- 19) A/C and PRESSURIZATION panel
- 20) Cockpit thermostatic valve
- 21) Cockpit fan
- 22) Cockpit evaporator
- 23) Cockpit blown temperature sensor (CKBTS)

Figure 7.9.2 (1/3) - GAS items list and abbreviations

- 24) Demisting microswitch
- 25) Hot air distributor (HAD)
- 26) Cabin inlet temperature sensor (ITS)
- 27) Cabin bleed temperature switch (BTSW)
- 28) Mixing ejector (MIXEJ)
- 29) Check valve
- 30) MFD unit
- 31) Ground safety microswitch
- 32) Differential pressure switch
- 33) By-pass valve (BPV)
- 34) Cabin altitude alarm switch
- 35) Emergency air supply system
(EMERGENCY RAM AIR)
- 36) Main heat exchanger (MHX)
- 37) Ground fan (GF)
- 38) Flow control shut off valve (FCSOV)
- 39) Bleed differential pressure sensor (BDPS)
- 40) Compressor
- 41) Shut-off valve (SOV)
- 42) Overheat thermal switch (OTSW)
- 43) Non return valve (NRV)
- 44) Intermediate port pressure sensor (IPPS)
- 45) Cabin pressure sensor

Figure 7.9.2 (2/3) - GAS items list and abbreviations

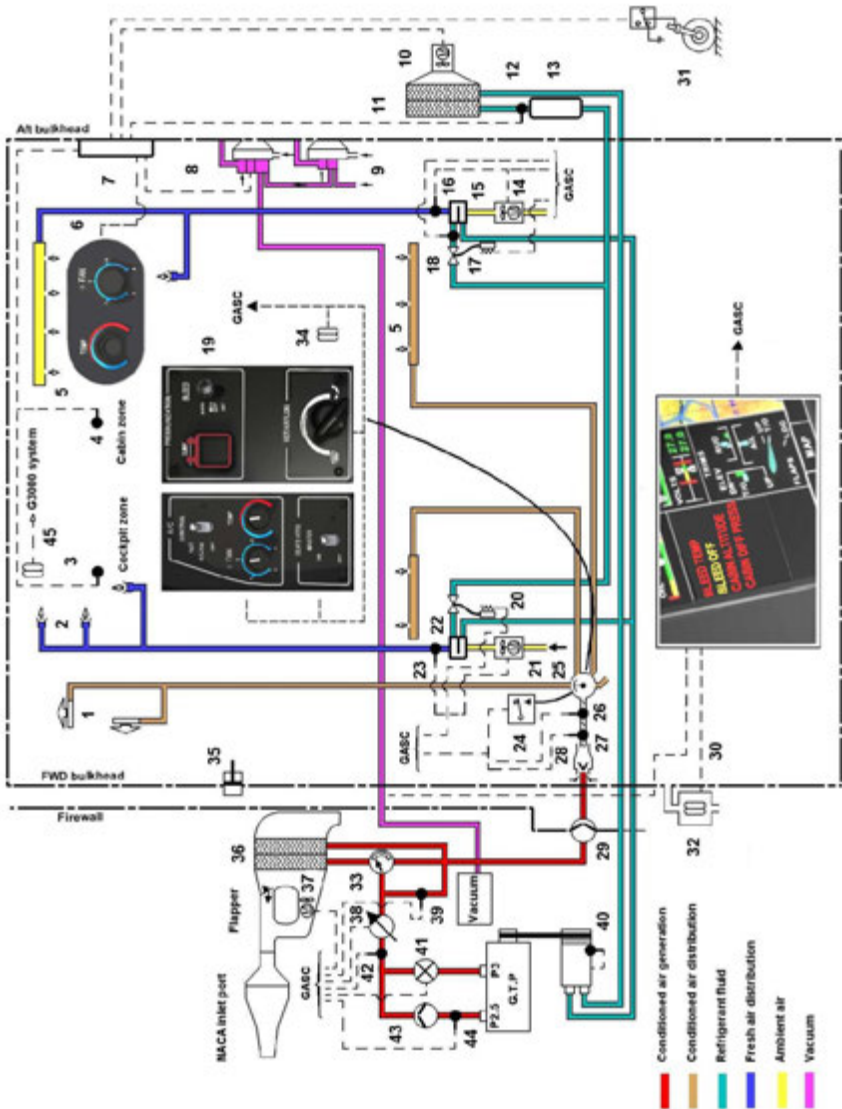
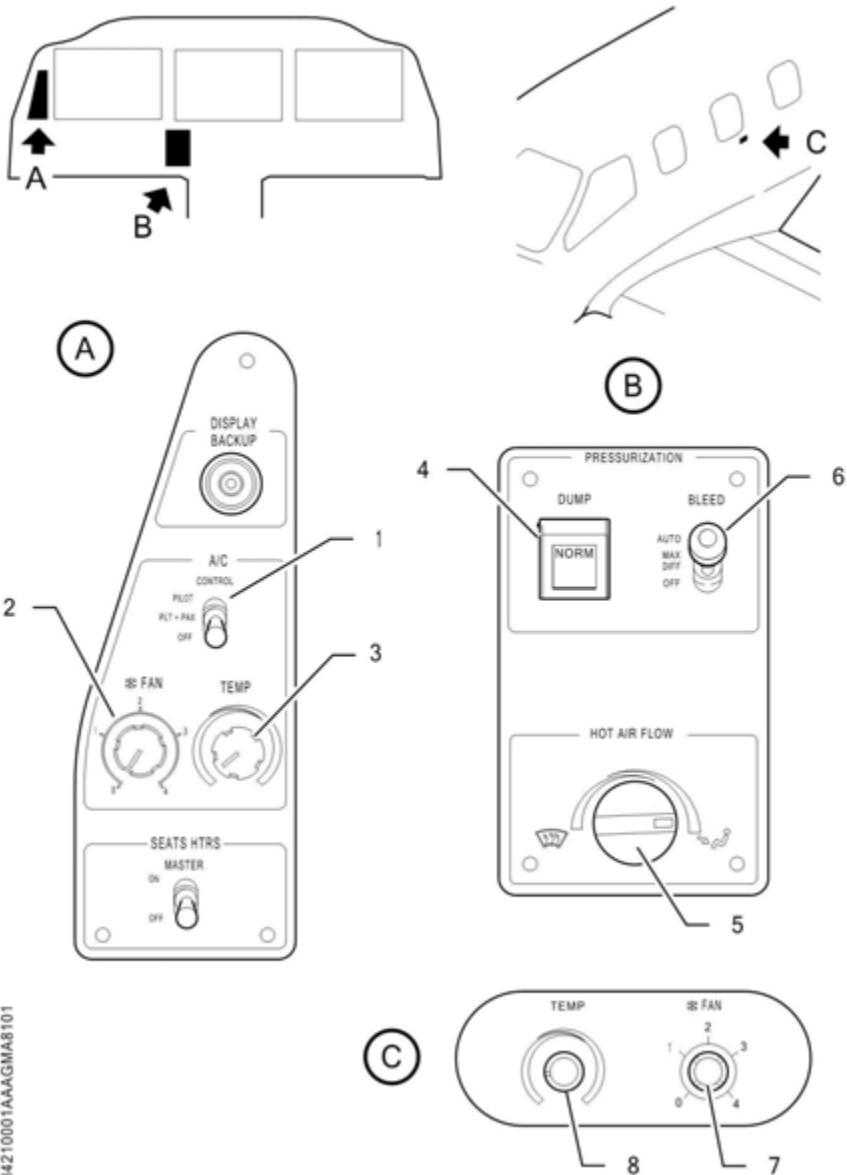

Figure 7.9.2 (3/3) - GAS

- 1) A/C switch
- 2) FAN speed selector (cockpit/cabin)
- 3) TEMP selector (cockpit/cabin)
- 4) DUMP switch
- 5) HOT AIR FLOW distributor
- 6) BLEED switch
- 7) FAN speed selector (cabin)
- 8) TEMP selector (cabin)

Figure 7.9.3 (1/2) - GAS controls



14210001AAAAGMA8101

Figure 7.9.3 (2/2) - GAS controls

Intentionally left blank

7.10 - Emergency oxygen system - see figure 7.10.1

The gaseous oxygen system is to be used by the crew and the passengers when the cabin altitude is greater than 10000 ft following a loss of pressurization, or if there is smoke or fumes in the cabin.

USE OXYGEN MASK appears in the MFD CAS window (in normal conditions) and the USE OXYGEN MASK/USE OXYGEN MASK aural warning alert sounds when the cabin altitude is greater than 10000 ft.

The oxygen reserve is contained in an oxygen cylinder made of composite material and located outside of the pressurized cabin in a compartment in the right wing fairing. Its capacity is 50.3 cu.ft (1425 litres) STPD and use limit pressures are :

- maximum pressure 1850 PSIG (127 bars) at 70° F (21° C). The maximum pressure for different outside temperatures is provided in section 8, figure 8.7.4, as well as on a placard on the inside of the cylinder service door,
- minimum pressure 217 PSIG (15 bars).

▲ CAUTION ▲

If the oxygen cylinder pressure falls below the minimum, the cylinder must be purged before refilling.
Inform maintenance department.



The oxygen cylinder head is equipped with :

- a hand-controlled isolation valve to permit cylinder installation and removal,
- a microswitch that triggers **O2 CYL CLOSED** . This message is ON when the isolation valve is closed,
- a graduated pressure gauge,
- a charging valve ; refer to the replenishment procedure in section 8,
- an overpressure system consisting of a safety disc. This disc is designed to rupture between 2500 and 2775 PSIG (172 and 191 bars) discharging the cylinder contents overboard,
- a pressure-reduction valve that regulates oxygen pressure to the masks at between 64 and 85 PSIG (4.4 and 5.9 bars),
- a low pressure safety valve calibrated to 116 PSIG (8 bars).

A control panel located in the cockpit overhead panel at the disposal of the pilot includes :

- a two-position valve ON/OFF (OXYGEN switch) to permit the supply of the front seats occupiers masks,
- a two-position valve DEPLOY/STBY (PASSENGER OXYGEN switch) with guard to permit the supply of the four passenger masks, when the OXYGEN switch is set to ON.

Oxygen pressure is displayed on the MFD.

An altimetric valve provides an automatic actuation function for passenger masks at a cabin altitude between 13000 and 14000 ft when the OXYGEN switch is set to ON.

Two pressure-demand type masks that allow quick donning with only one hand to cover the nose and the mouth are at disposal of the pilot and the front passenger, along with two pairs of smoke goggles. These masks are installed in cups on the cabin walls aft of the front seats. For the ease of donning and for ergonomic reasons, the pilot's mask is located in the right-side cup, and the front passenger mask is located in the left-side cup. The masks are permanently connected to the oxygen system.

The smoke goggles are stowed in the cabinet drawer behind the right front seat.

Each cockpit mask is equipped with :

- 1 - a microphone, controlled by the MICRO/MASK switch under cover located on the instrument panel near the left control wheel.

>> *Airplane equipped with MC10 Smart Mike oxygen masks*

- 2 - a Smart Mike system that reduces the breathing noise in the headsets. The noise reduction function operates when the switch located on the O₂ connecting line is set to ON - see figure 7.10.3.

>> *All*

- 3 - a vent valve integrated in the facepiece of the mask to provide airflow to the goggles.

• NOTE •

Manual opening of the vent valve is necessary when goggles are in place.

•

4 - a regulator equipped with :

- a two-position N-100% control tab that selects between a mix of cabin air and oxygen (NORMAL mode) and 100% oxygen (100% mode),
- an EMERGENCY rotating knob with a PRESS TO TEST function.

● NOTE ●

When smoke or fumes are present, the mask can be set to provide positive pressure to prevent smoke or fumes from infiltrating the mask and to provide airflow to clear the goggles. Push the N-100 % control tab in towards the mask to the 100 % position and turn the EMERGENCY control knob to the EMERGENCY position. After donning the goggles, open the goggle vent on the bridge of the mask by pulling the slide fully downwards.



▲ CAUTION ▲

Use of 100% oxygen and/or the EMERGENCY pressurized breathing function will significantly decrease oxygen duration.



A flow indicator (blinker) into the oxygen tubing signals the proper flow.

Depending on the specific airplane configuration, refer to the mask manufacturer's documentation available on the MyTBM.aero website for more information.

Four passenger constant-flow type masks covering the nose and the mouth and permanently connected, are installed in two containers on the cabin ceiling. The opening of these containers and the deployment of the masks are controlled:

- by the pilot, when the OXYGEN switch is set to ON and the PASSENGER OXYGEN switch is set to DEPLOY,
- or automatically at a cabin altitude between 13000 and 14000 ft with the OXYGEN switch set to ON.

Oxygen flow to the passenger masks is obtained when the passenger pulls on the lanyard to release the connected pin. The green bag on the oxygen mask inflates when oxygen flow is obtained.

▲ WARNING ▲

**Smoking is strictly prohibited when the oxygen system is in use.
Before using oxygen, remove any trace of oil, grease, soap and
other fatty substances (including lipstick, make-up, etc.).**



- 1) MICRO/MASK switch
- 2) OXYGEN switch
- 3) PASSENGER OXYGEN switch

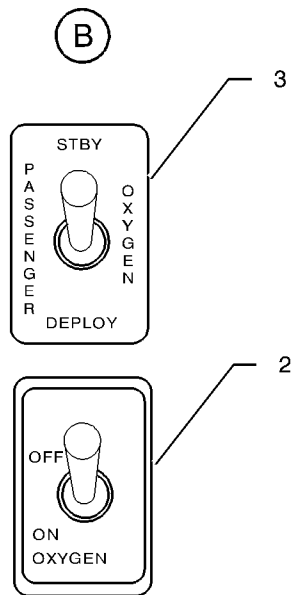
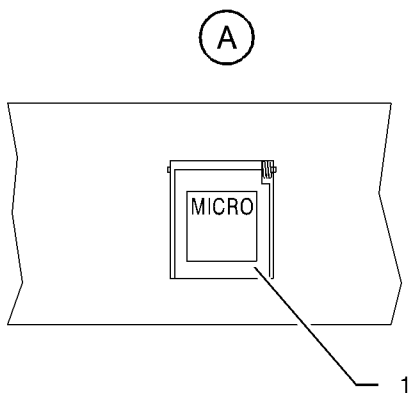
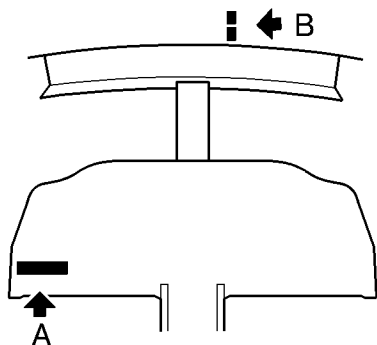

14231204AAAFMA8002

Figure 7.10.1 - Emergency oxygen system

- 1) Harness inflation side vanes
- 2) N (Normal) – 100% regulator control tab
- 3) EMERGENCY control knob
- 4) PRESS TO TEST function
- 5) Vent valve

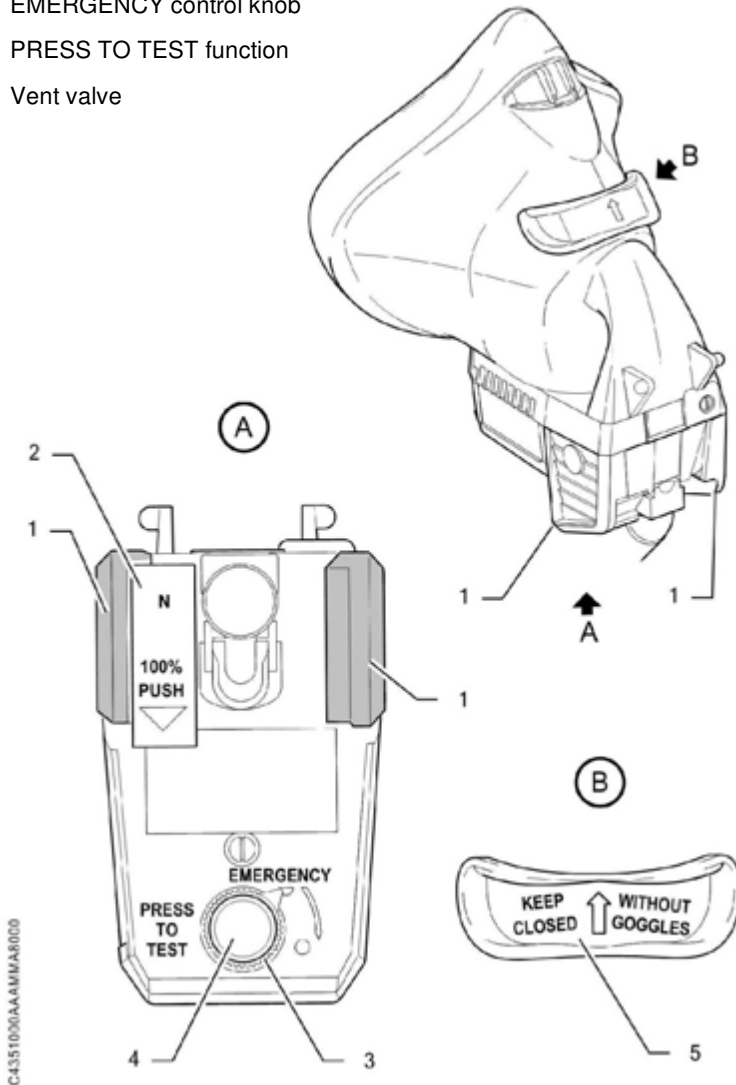

Figure 7.10.2 - Crew oxygen masks - Regulator controls

>> Airplane equipped with MC10 Smart Mike oxygen masks

14351100AAAEMIA8000

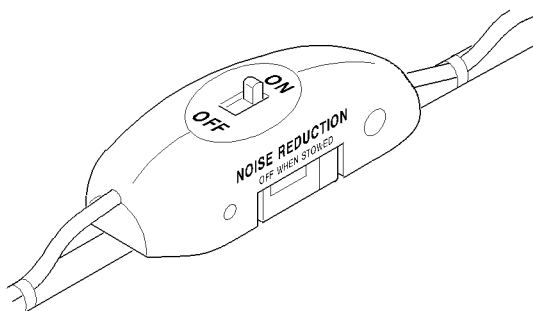

Figure 7.10.3 - Crew oxygen masks - Noise reduction switch

>> All

Flight above 15000 ft with possible emergency descent

Minimum oxygen pressure (PSIG) for following conditions :

- Crew oxygen masks in NORMAL mode.
- 4 minutes of utilization by each pilot and passenger from 31000 ft to 15000 ft.
- Plus 30 minutes of utilization by each pilot and passenger at 15000 ft.
- Plus 86 minutes of utilization by each pilot at 10000 ft.

Number of occupants		Outside temperature						
Cockpit	Cabin	110° F/ 43° C	90° F/ 32° C	70° F/ 21° C	50° F/ 10° C	30° F/ -1° C	10° F/ -12° C	-10° F/ -23° C
1	0	631	614	597	580	563	546	529
1	1	759	736	713	691	668	646	623
1	2	885	856	828	799	771	743	715
1	3	1010	976	941	907	873	839	806
1	4	1137	1096	1056	1015	975	935	897
2	0	1037	1001	965	930	894	859	825
2	1	1164	1122	1080	1038	997	956	916
2	2	1289	1241	1192	1144	1097	1050	1004
2	3	1416	1361	1306	1252	1198	1145	1093
2	4	1541	1480	1418	1357	1297	1238	1180

Figure 7.10.4 - Minimum oxygen pressure (PSIG)
[Flight above 15000 ft with possible emergency descent]

• NOTE •

Increase the pressure in the table by 8 % if the airplane has been parked in sunlight for an extended period of time.

•

When required to remain above 15000 ft due to minimum enroute altitude

Minimum oxygen pressure (PSIG) for following conditions :

- Crew oxygen masks in NORMAL mode.
- Flight above 15000 ft. All equipment in use.
- 1 hour of utilization by each pilot and passenger.
- Plus 1 hour of utilization by each pilot under 15000 ft.

Number of occupants		Outside temperature						
Cockpit	Cabin	110° F/ 43° C	90° F/ 32° C	70° F/ 21° C	50° F/ 10° C	30° F/ -1° C	10° F/ -12° C	-10° F/ -23° C
1	0	618	602	585	569	552	536	520
1	1	842	816	789	763	736	710	685
1	2	1067	1029	992	955	918	882	846
1	3	1513	1240	1192	1144	1097	1050	1004
1	4	1513	1452	1392	1333	1275	1217	1161
2	0	992	958	925	891	858	825	793
2	1	1215	1170	1125	1081	1037	994	952
2	2	1439	1382	1326	1270	1215	1161	1108
2	3	1662	1593	1525	1457	1391	1326	1262
2	4	1888	1807	1725	1645	1567	1490	1415

Figure 7.10.5 - Minimum oxygen pressure (PSIG)
[When required to remain above 15000 ft due to minimum enroute altitude]

• NOTE •

Increase the pressure in the table by 8 % if the airplane has been parked in sunlight for an extended period of time.

•

Flight between 15000 ft and 10000 ft

Minimum oxygen pressure (PSIG) for following conditions :

- Crew oxygen masks in NORMAL mode.
- Flight under 15000 ft.
- 90 minutes of utilization by each pilot and **one** passenger.
- Plus 30 minutes of utilization by each pilot at 10000 ft.

Number of occupants		Outside temperature						
Cockpit	Cabin	110° F/ 43° C	90° F/ 32° C	70° F/ 21° C	50° F/ 10° C	30° F/ -1° C	10° F/ -12° C	-10° F/ -23° C
1	0	618	602	585	569	552	536	520
1	1	961	929	896	864	833	801	770
1	2	961	929	896	864	833	801	770
1	3	961	929	896	864	833	801	770
1	4	961	929	896	864	833	801	770
2	0	992	958	925	891	858	825	793
2	1	1333	1282	1231	1181	1131	1083	1035
2	2	1333	1282	1231	1181	1131	1083	1035
2	3	1333	1282	1231	1181	1131	1083	1035
2	4	1333	1282	1231	1181	1131	1083	1035

Figure 7.10.6 - Minimum oxygen pressure (PSIG)
[Flight between 15000 ft and 10000 ft]

• NOTE •

Increase the pressure in the table by 8 % if the airplane has been parked in sunlight for an extended period of time.

•

Intentionally left blank

7.11 - Air data system and instruments - see figure 7.11.1

The airplane air data system consists of :

- Primary systems :
 - two separate static pressure systems,
 - two separate dynamic pressure systems.
- An alternate static pressure system.

Static pressure systems

Primary systems

Two dual static ports (one on each side of the fuselage tail section) supply a dual system routed to the cockpit.

Static system 1 supplies :

- ADC 1
- the standby instrument, through the Normal / Alternate static source switching valve, when the ALTERNATE STATIC SOURCE selector is in the Normal position (pushed). The ALTERNATE STATIC SOURCE selector is located on the instrument panel under the right-side control wheel.

Static system 2 supplies ADC 2.

Each line has a drain plug located under the instrument panel on the right side.

Alternate static source

The alternate static port, located inside the rear fuselage, supplies a line routed to the Normal / Alternate static source switching valve.

If a false airspeed indication or primary static system failure is suspected, the pilot can pull the ALTERNATE STATIC SOURCE selector fully out to select the alternate static source. In that case, static pressure from the alternate line is only provided to the standby instrument. Static pressure from the alternate line is not provided to either ADC.

▲ CAUTION ▲

Do not rely on PFD indications when the alternate static source is selected. Only refer to the standby instrument for airspeed and altitude.



The alternate line has a drain plug located under the instrument panel on the right side.

Dynamic pressure systems

Dynamic pressure is provided by two heated pitot probes, one installed under each wing.

The left probe supplies ADC 1 and the standby instrument.

The right probe supplies ADC 2.

Each line has a drain plug located in the root of the wing.

Pitot heating

Pitot heating is controlled by PITOT L HTR and PITOT R & STALL HTR switches located on DE-ICE SYSTEM panel. Refer to chapter 7.13 for further details.

▲ **CAUTION** ▲

On the ground, do not turn on pitot heat for long periods to avoid probe overheating.



Intentionally left blank



- 
- 
- 
- 1) Pitot L
 - 2) Dynamic system drain
 - 3) Standby instrument
 - 4) ADC 1
 - 5) ADC 2
 - 6) Forward pressure bulkhead
 - 7) Static system drain
 - 8) Static system drain
 - 9) Static system drain
 - 10) Alternate static system drain
 - 11) Static source switching valve (Normal / Alternate)
 - 12) Instrument panel
 - 13) Dynamic system drain
 - 14) Pitot R
 - 15) Rear pressure bulkhead
 - 16) Static port
 - 17) Alternate static port
 - 18) Static port

Figure 7.11.1 (1/2) - Air data system



14341000AACAMIA18000

Figure 7.11.1 (2/2) - Air data system

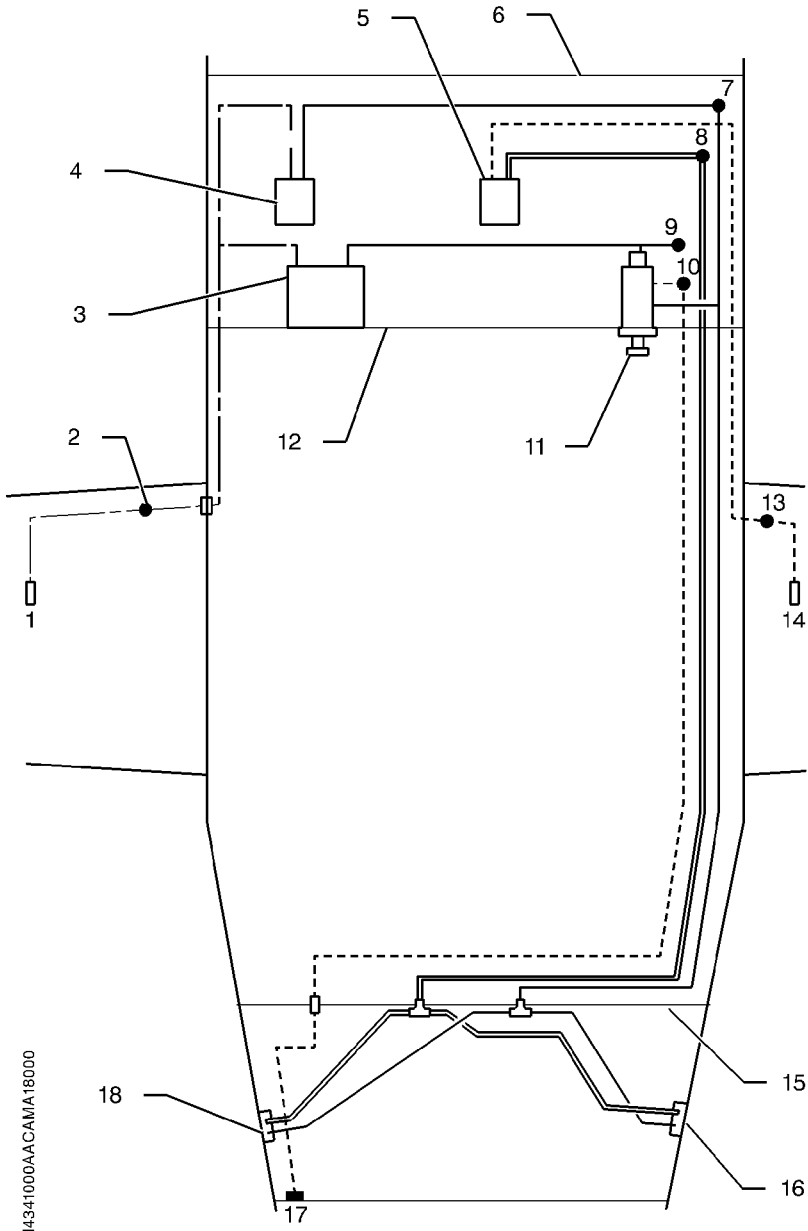
Intentionally left blank

7.12 - Vacuum system and instruments - see figure 7.12.1

The airplane is fitted with a vacuum system providing the suction necessary to operate the cabin pressurization and the leading edge deicing.

Vacuum system includes :

- A pressure regulator
- An ejector
- A regulating and relief valve
- A pressure switch

Compressed air necessary for the ejector to create decompressed air is taken from the powerplant. The air flow is regulated before going into the ejector which creates necessary vacuum by venturi effect.

A relief valve fixed in cabin to frame C2, maintains the vacuum for pressurization system. In case of pressure drop, a pressure switch, installed in the system, indicates the failure by causing **VACUUM LOW** to light on.

Standby attitude module (MD302)

The Mid-Continent Instrument and Avionics MD302 Standby Attitude Module consists of two LCD screens. The first screen displays the airplane attitude (pitch and roll) and the second screen displays the airplane altitude and airspeed. The MD302 is powered from the ESSENTIAL BUS 2 or internal replaceable battery ensuring that the airplane can continue safe flight and landing in the event of a loss of primary attitude and air data displays. Pitot and static pressures are provided to the MD302 solid state electronic sensors using the airplane pitot probe and static sources.

The standby attitude module is located in the top left hand corner of the instrument panel.

- 1) Pressure regulator
- 2) Ejector
- 3) Valve
- 4) Regulating and relief valve
- 5) Pressure switch
- 6) Failure CAS message

Figure 7.12.1 (1/2) - Vacuum system

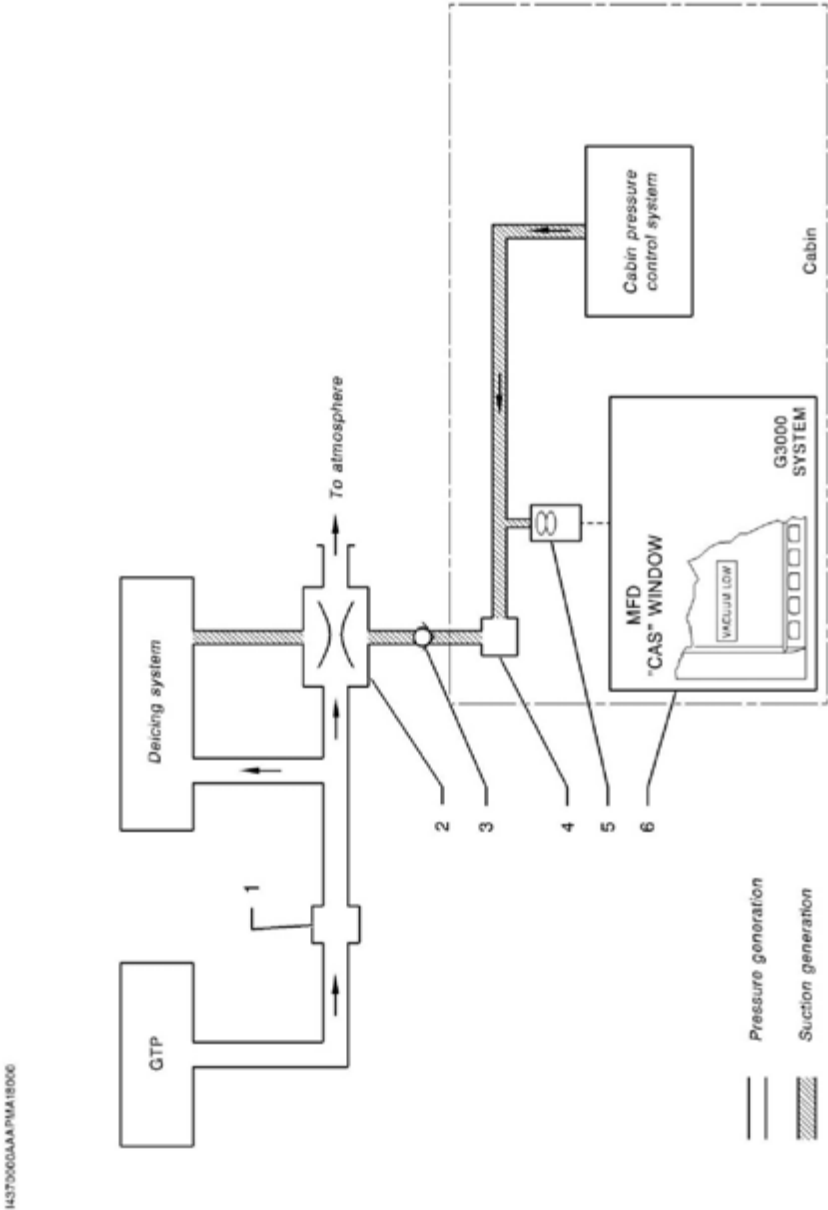

Figure 7.12.1 (2/2) - Vacuum system

Intentionally left blank

7.13 - Ice protection equipment - see figure 7.13.1

Ice protection equipment is as follows :

- Pneumatic deice system for inboard, central and outboard wing and for stabilizers : AIRFRAME DE ICE
- Propeller electrical deice system : PROP DE ICE
- Windshield electrical deice system : WINDSHIELD
- Electrical heating system for both pitots and for the stall warning sensor : PITOT L HTR and PITOT R & STALL HTR
- Turbine air inlet deice systems : INERT SEP

Deicing check and control panel is located on the lower L.H. side of the instrument panel.

Wing and empennage deicing

A pneumatic deice system assures protection of wing leading edges, horizontal stabilizer, elevator horns and vertical stabilizer. The system automatically cycles when AIRFRAME DE ICE switch is set to ON. The 67-second cycle breaks down in two inflation cycles :

- a first cycle induces inflation of leading edges deicer boots in wing central and outboard sections.
- the second cycle induces inflation of leading edges deicer boots in horizontal stabilizer, elevator horns, vertical stabilizer and wing inboard section,

During each inflation cycle, one of the two corresponding warning lights located above AIRFRAME DE ICE switch, remains illuminated.

Wing leading edge icing inspection light - see chapter 7.8 paragraph Exterior lighting.

Propeller deicing

Propeller deicing is accomplished through electrical heating of blade roots. This system operates cyclically and alternately on the inboard and outboard zones of all blades. Each cycle is 180 seconds long. The system operation is correct when green warning light located above PROP DE ICE switch illuminates. The cycles continue as long as the switch remains set to ON.

PROP DE ICE ON illuminates if the engine is shut down with PROP DE ICE switch still ON.

▲ CAUTION ▲

When engine is shutdown, do not set the PROP DE ICE switch to ON for more than 10 seconds, damage to the propeller blades could result.



Windshield deicing

The windshields are deiced electrically by integrated heating resistors. The system includes a controller and two heat probes embedded in each windshield. They are operated by the WINDSHIELD switch.

When the switch is positioned to ON, the controller supplies the heating resistors, the windshield temperature is monitored by probe 1. When the temperature reaches 45°C (113°F), the controller cuts the electrical supply to the heating resistors and resumes supply when the temperature falls below 30°C (86°F). The cycle continues as long as the switch remains set to ON.

In the event of failure of probe 1, the controller receives the temperature data from probe 2. The electrical supply to the heating resistors is cut when the windshield temperature reaches 56°C (133°F). In that case, the windshield is no longer heated, the pilot can reset the system by setting the switch to OFF, then to ON.

Two green lights located above the WINDSHIELD switch go on when the corresponding heating resistors are being supplied.

Heating of pitots and stall warning sensor (PITOT L HTR and PITOT R & STALL HTR)

The two pitots, which supply ADCs, the airspeed indicator and the stall warning sensor are electrically heated. This deice equipment must be used even during flight into non-icing conditions.

The system condition messages **PITOT NO HT L** or **PITOT NO HT R**, **PITOT HT ON L** or **PITOT HT ON R**, **STALL HEAT ON** or **STALL NO HEAT** are displayed on the MFD CAS window. Refer to the GARMIN Pilot's Guide for further details.

• NOTE •

Correct operation of the audible stall warning may be altered by severe or prolonged icing.

•

Turbine air inlet protection

Operation and description are set forth in chapter 7.6 paragraph Engine air inlet.

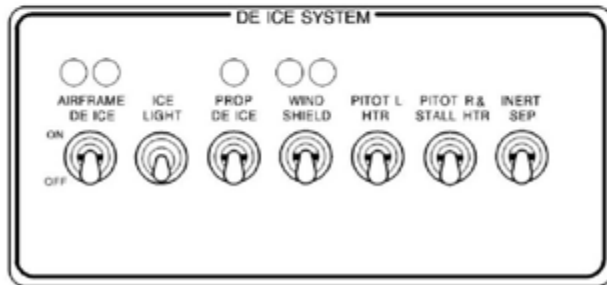
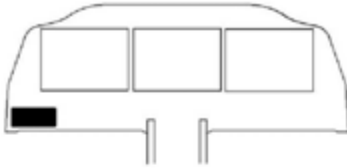

14300001AAAIGMAB100

Figure 7.13.1 - Deicing control and check panel

7.14 - Miscellaneous equipment

Stall warning system

The airplane is equipped with an electrically deiced stall sensor in the leading edge of the right wing. This sensor fitted with a vane is electrically connected to an audible warning. The vane senses the change in airflow over the wing and operates the warning unit, which produces an aural warning alert. This warning alert begins no later than 5 knots above the stall in all configurations.

Simultaneously, the control wheel vibrates through the stick shaker.

The stall warning system should be checked during the preflight inspection by momentarily turning on the SOURCE selector and by manipulating the vane in the wing.

The stall warning system should also be checked during the preflight inspection by momentarily turning on the SOURCE selector and by depressing the TEST push-button on cockpit overhead panel.

The system is operational if a stall / stall aural warning alert is heard on the alarms speaker.

• NOTE •

The audible stall warning may be altered by severe or prolonged icing.

•

Static dischargers

As an aid in flight, static dischargers are installed to improve radio communications during flight by reducing interference from dust or various forms of precipitations (rain, snow or ice crystals).

Under these conditions, the build-up and discharge of static electricity from the trailing edges of the wings (flaps and ailerons), rudder, stabilator, propeller tips and radio antennas can result in loss of usable radio signals on all communications and navigation radio equipment. Usually, the ADF is first and VHF communication equipment is the last to be affected.

Installation of static dischargers reduces interference from precipitation static, but it is possible to encounter severe precipitation static conditions which might cause the loss of radio signals, even with static dischargers installed. Whenever possible, avoid known severe precipitation areas to prevent loss of dependable radio signals. If avoidance is impractical, minimize airspeed and anticipate temporary loss of radio signals while in these areas.

Cabin fire extinguisher

The fire extinguisher is located on R.H. front station side panel.

A pressure gage allows checking the fire extinguisher condition. Follow the recommendations indicated on the extinguisher.

Autopilot

Autopilot control panel is located above the MFD. Refer to section 2 Limitations of this POH and to GARMIN Pilot's Guide for further details.

GPS

GPS navigation is performed through the GARMIN system. Refer to section 2 Limitations and section 4 Normal procedures of this POH and to GARMIN Pilot's Guide for further details.

Weather radar GWX 70

The weather information can be displayed on PFD1, PFD2 and MFD.

Refer to section 2 Limitations of this POH and to GARMIN Pilot's Guide for further details.

The controls for the weather radar are located on the touchscreen controllers.

- The weather radar is protected by the WXR breaker.

- 1) MFD
- 2) Radar mode
- 3) Area of weather display
- 4) Antenna stabilization status
- 5) Touchscreen controllers
- 6) Scale for weather display

Figure 7.14.1 (1/2) - GWX 70 Weather radar display and controls

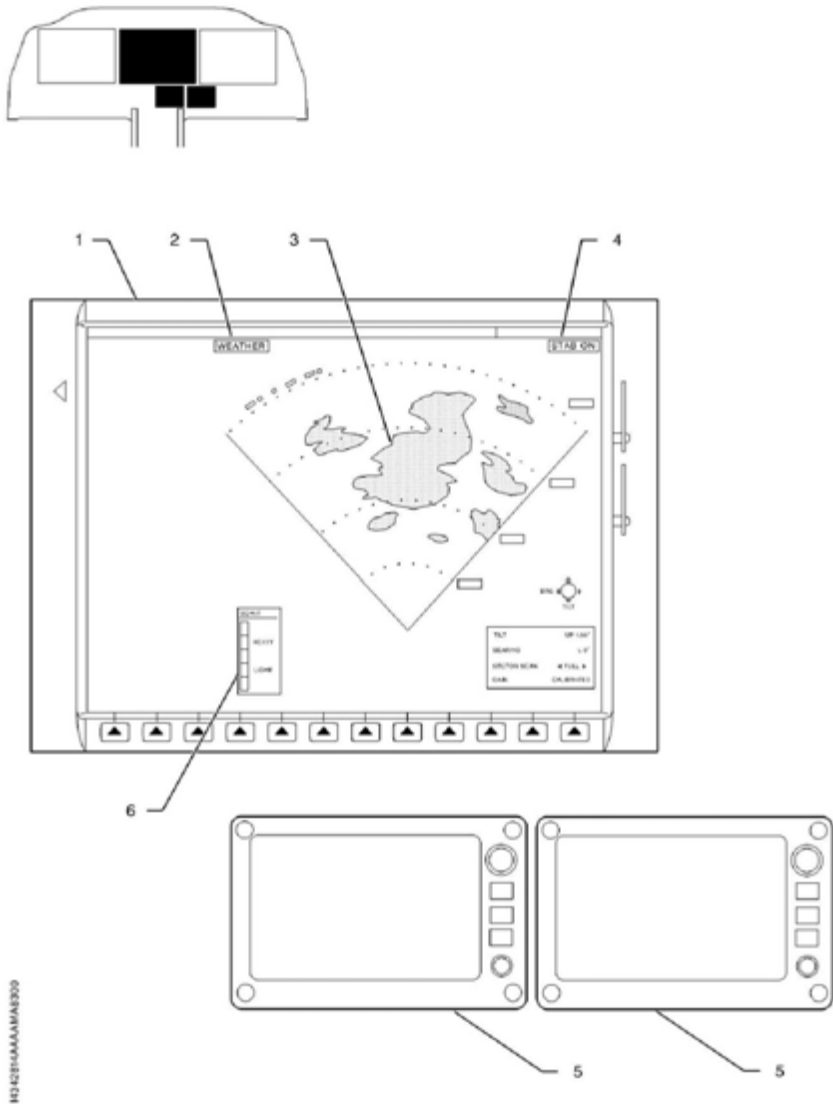

HD 02F000000000

Figure 7.14.1 (2/2) - GWX 70 Weather radar display and controls

Emergency locator transmitter

The airplane is equipped with an ELT ARTEX 1000 emergency locator transmitter which enables to locate it in case of distress. It is located in fuselage rear section with a service door on fuselage R.H. side.

The emergency locator transmitter assembly is constituted of a transmitter supplied by a battery, of an antenna attached on upper fuselage and of a remote control located on the upper panel.

● NOTE ●

For test sequences, refer to manufacturer manual.



Operation of the emergency locator transmitter is obtained as follows :

- from the instrument panel by setting ELT remote control switch to ON (locator transmitter ARM/OFF switch set to ARM/OFF),
- from the locator transmitter by setting its ARM/OFF control switch to ON,
- automatically in case of shock, when remote control switch is set to ARM/OFF and locator transmitter switch is set to ARM/OFF.

A red indicator light located on ELT remote control switch in the cockpit indicates to the pilot the emergency locator transmitter is transmitting.

A red indicator light located above locator transmitter switch and a buzzer located in the fuselage rear section indicate the emergency locator transmitter is transmitting.

▲ CAUTION ▲

Reset the ELT after an inadvertent activation.



● NOTE ●

The ELT cannot be reset if either the remote control switch or ELT switch is ON.



Reset procedure :

- 1) Set remote control switch or ELT switch to ON.
 - a) The ELT keeps on transmitting emergency signal.
 - b) On remote control box, red indicator light flashes.
 - c) On ELT, red indicator light flashes.
 - d) Near ELT, the buzzer sounds.
- 2) Wait approximately for 1 second.

- 3) Set remote control switch to ARM/OFF or ELT switch to ARM/OFF.
 - a) The ELT does not transmit emergency signal any longer.
 - b) On remote control box, red indicator light illuminates for about 1 second, then goes off.

or
 - c) On ELT, red indicator light goes off.
 - d) Near ELT, the buzzer does no more sound.

Then ELT is reset.

End of procedure.

Lightweight data recorder (LDR 1000)

The airplane is equipped with a lightweight data recorder which is a crash-survivable system, recording both cockpit voices and flight data. These data are intended to be used after an accident or an incident.

The lightweight data recorder system includes a cockpit microphone located on instrument panel, between the standby instrument and the autopilot control panel.

The lightweight data recorder simultaneously records audio from the GMA audio control panel, audio from the cockpit microphone, data from the GASC, and data from the GIA integrated avionics unit 1 (GARMIN flight deck system).

The lightweight data recorder is powered from the BATT BUS and controlled by a printed circuit as follows :

- If the crash lever is set upward, the lightweight data recorder starts recording.
- If the crash lever is set downward, the lightweight data recorder goes on recording for 10 minutes (audio only) and then automatically stops recording.

ADS-B OUT function

The ADS-B OUT function enables the airplane to broadcast data, such as position information, to ground stations and to other airplanes equipped with ADS-B IN system.

The loss of an interfaced input to the selected extended squitter transponder may cause the transponder to stop transmitting ADS-B OUT data. Depending on the nature of the fault or failure, the transponder may no longer be transmitting all of the required data in the ADS-B OUT messages.

ADS-B OUT data can be transmitted via transponder 1 or transponder 2, if installed.

If the transponder 1 [2] detects any internal fault or failure with the ADS-B OUT functionality, the following CAS message **XPDR1 ADS-B FAIL**

XPDR2 ADS-B FAIL will be displayed on the MFD CAS window.

After being informed of ADS-B OUT failure either by the CAS message **XPDR1 ADS-B FAIL** **XPDR2 ADS-B FAIL** or by Air Traffic Control, it is possible to restore ADS-B OUT function by selecting transponder 2 [1].

Flight deck information system (FS 510), if installed

The airplane is equipped with a flight deck information system allowing portable electronics devices to stream data to and from the GARMIN system.

For the system description and its utilization, refer to GARMIN Pilot's Guide.

Data collection and transmission system (FASTBOX), if installed

The data collection and transmission system collects data from airplane data buses and discrete inputs and stores it in resident non-volatile memory.

When the airplane is on the ground and a few minutes after the engine shut-down, recorded data are automatically transmitted to a ground station via the cellular or WiFi network. These data are intended to be used for maintenance and trend monitoring.

The data collection and transmission system records data from the GASC and data from the GIA (GARMIN integrated flight deck system).

The data collection and transmission system starts recording data as soon as the engine is running, and stops recording data when the engine is shutdown.

The data collection and transmission system is installed in the front cargo compartment, and does not require a pilot input to operate.

The data collection and transmission system is powered from the BATT BUS and protected by the REC circuit breaker.

GARMIN Integrated Flight Deck (GIFD) approaches

The purpose of this section is to provide an overview of the GIFD capabilities and operation related to GIFD Approaches.

Detailed descriptions as well as operating instructions of these approaches are provided in the applicable Pilot's Guide and Cockpit Reference Guide.

RNP approaches operation

The GIFD is capable of performing approaches with GNSS guidance also designated as RNP approaches.

RNAV (GPS) or RNAV (GNSS) – **LNAV, LNAV+V**

LNAV approaches provide lateral GPS-based guidance to legs defined by the navigation database.

Vertical deviations may be available if the necessary information to construct a vertical path is contained in the database.

Any vertical path information for LNAV approaches is strictly advisory.

There is no guarantee that stepdown fix altitudes will be honored and the crew must level off at the MDA if the runway is not visible.

LNAV approaches may be executed with or without SBAS, and advisory vertical guidance is dependent on sufficient GPS vertical error estimates rather than SBAS vertical integrity.

LNAV+V approaches do not downgrade in general because they do not require SBAS, although high GPS vertical error estimate anomalies could result in loss of advisory vertical guidance.

If GPS is lost the LNAV approach will be aborted.

RNAV (GPS) or RNAV (GNSS) – L/VNAV

LNAV/VNAV approaches add published vertical guidance in addition to LNAV guidance. They are different from LNAV+V in that the vertical deviations are not advisory, but rather published guidance.

The minimums of an LNAV/VNAV approach represent a DA rather than an MDA.

Execution of an LNAV/VNAV approach does not require SBAS integrity, as long as a system is configured to support barometric VNAV for approach.

If SBAS integrity is available, it will be used to provide vertical guidance.

During execution of a GPS approach with LNAV/VNAV service levels, while the aircraft is between the FAF and MAP, excessive deviation indicators appear as white vertical lines to indicate an area where the vertical deviation exceeds ± 75 feet.

If the glide-path indicator is within an area of excessive deviation, the glide-path indicator becomes yellow and the vertical lines also become yellow.

RNAV (GPS) or RNAV (GNSS) – LPV

LPV approaches provide both localizer precision lateral guidance and a vertical path definition.

SBAS integrity is required to execute the approach.

BARO-VNAV approaches

The GIFD provides the ability to conduct barometric based VNAV operations while conducting certain GPS approaches using an automatically generated temperature compensated glidepath.

Baro-VNAV Approach functionality is separate and distinct from enroute and terminal descent VNAV functions.

■ Temperature Compensation

If SBAS is unavailable or disabled, the GIFD will provide automatic temperature compensated glidepath vertical guidance on approaches that have LNAV/VNAV minima published, or on some approaches that are not authorized for SBAS.

No pilot action is required to receive the temperature compensated glide-path when SBAS is not available or allowed.

■ Final Approach Segment (FAS)

Altimeter systems assume an ISA temperature model.

When actual atmosphere deviates from the ISA model it results in altitude errors.

For example, performing a Baro-VNAV during a hot day would result in guidance relative to a glide path angle steeper than the published glide path angle. On the contrary, during a cold day, a Baro-VNAV would be based on guidance relative to a glide path smoother than the published glide path angle.

The approach plates indicate a temperature range for which the approach has been designed.

Within this temperature range the LNAV/VNAV can be used with uncompensated Baro-VNAV systems.

Outside of this temperature range, LNAV/VNAV minimums shall not be used with uncompensated Baro-VNAV systems.

The GARMIN Approach Baro-VNAV system is automatically temperature compensated to produce a glide-path position in space such that Baro-VNAV approaches are always flown at the published glide path angle when the actual temperature deviates from the ISA model. This produces results similar to ILS glideslopes and LPV glide-paths that remain in the same position in space without respect to temperature.

To produce the correct geometric glide path angle on the final approach segment, temperature compensation is applied to the barometric altitude and used to determine the displayed vertical deviation.

However, the altimeter continues to display uncompensated barometric altitude.

The temperature compensation required depends on the temperature profile over the altitude range between the point at which the barometric setting is measured (presumed to be the approach airport) and the present altitude of the aircraft.

This temperature profile is estimated by using the air data system static air temperature (SAT) and applying the standard temperature lapse rate to determine the temperature over the rest of the range.

When using barometric altitude for vertical guidance along the final approach segment, temperature compensation is applied whether the temperature is above or below standard temperature. The actual compensated altitude is not displayed to the pilot during an approach.

■ Compensating Waypoint Altitudes

Depending on the terrain, temperature compensation may be required for waypoints in the approach prior to the final approach segment due to terrain and/or obstacle clearance requirements.

■ Temperature Compensation of Approach Minimums

To enable temperature compensation of the minimum altitude, select the TEMP COMP, option for the minimum altitude reference type (in addition to OFF, BARO, and RAD ALT). The temperature at the destination airport is used for this purpose.

The temperature at the destination airport is invalidated when a different approach is loaded into the active flight plan or when the system powers up.

This disables temperature compensation of both the published approach waypoint altitudes on the active flight plan page and the minimum altitude.

The minimum altitude selection type changes to BARO if it was previously set to TEMP COMP.

Temperature compensation of the minimum altitude is not dependent on use of barometric altitude for vertical guidance on the FAS, and is therefore available for any type of approach; in fact, only the destination airport and temperature are required.

Compensating the approach minimums bug simply determines where the minimums reference is displayed on the altimeter.

No adjustment to the barometric altitude is made as a result of temperature compensating the minimums reference.

■ **Approach level downgrade**

Some automatic approach service downgrade may be performed automatically upon loss of SBAS or GPS approach alarm limits being exceeded, depending on the approach service level that has been loaded in the flight plan and activated.

This automatic downgrade is annunciated to the pilot through an **APR DWNGRADE** and a change in the annunciated service level in the HSI.

As the **APR DWNGRADE** may not be triggered under certain circumstances, the HSI annunciation shall be considered as the primary mean to annunciate any approach downgrade.

Under certain circumstances when the GNSS integrity requirement is not met, the approach may be aborted. This is annunciated through **ABORT APR**, while the service level annunciation is no longer displayed on the HSI.

If SBAS becomes unavailable on an RNAV LNAV/VNAV approach, **L/VNAV** is shown in yellow, the system switches to LNAV/VNAV (Baro-VNAV) service level and **APR DWNGRADE** will be generated (the VDI will be flagged NO GP until **APR DWNGRADE** has been acknowledged).

If **APR DWNGRADE** is acknowledged, the **L/VNAV** is shown in magenta.

If **APR DWNGRADE** is not acknowledged, the system will downgrade to LNAV service level, (**LNAV** shown in magenta), the VDI will remain flagged 'NO GP', and no additional downgrade system message will be generated.

If SBAS becomes unavailable on an RNAV LPV approach, **LPV** will be shown in yellow, but the CDI and VDI will continue to be shown. At one minute to the FAF, **APR DWNGRADE** will be generated.

The VDI will be flagged NO GP. Depending on the available lines of minima for the approach, the system will switch to either LNAV/VNAV or LNAV service level.

Advisory visual approaches

The GIFD will provide advisory visual approaches to many runways in the aviation database. Lateral guidance for the visual approach is aligned with the runway bearing. The system also generates vertical guidance from the runway threshold at a GIFD defined glide path (usually 3°, refer to the GARMIN Pilot's Guide for further information) allowing coupling of the autopilot to the appropriate minimums.

The pilot interface for visual approaches is an extension of the normal approach selection method. At the end of the list of instrument approaches, there will be a set of visual approaches added. Nominally, there will be a visual approach listed for each runway end. The approaches will be labeled with the name VISUAL and the runway number.

Each visual approach has two transitions : the Straight-in transition and the Vectors-to-Final transition. The transitions will be labeled STRAIGHT and VECTORS, respectively. The FMS creates the VISUAL approach waypoints (fixes) based on the runway position and course specified in the navigation database. These are defined in the following table:

Fix Identifier	Description	Distance to runway
RWxxx	Runway fix defined in the navigation database. "xxx" is the runway number and suffix (e.g. RW19L).	N/A
FINAL	The roll-out from the turn to the final approach course is accomplished as this fix is sequenced.	3.5 NM
STRGHT	Initial fix for the straight-in transition.	6 NM

The waypoints created by the FMS to define a VISUAL approach are fixes stored in the flight plan. When the approach is no longer a part of a flight plan, these waypoints are deleted. A VISUAL approach can be inserted onto the Active Flight Plan or the Standby Flight Plan. A VISUAL approach can also be inserted into a stored flight plan or copied to a stored flight plan in the course of saving the active or standby flight plan.

CDI and VDI indications are equivalent to those of other GPS-based approaches (e.g.- **LPV** or **L/VNAV**). The GIFD annunciates **VISUAL** in the HSI to indicate a visual approach is active.

When conducting a visual approach, it is the pilot's responsibility to ensure terrain and obstacle avoidance. The visual approach does not consider terrain or obstacles. It is important for the pilot to understand that the Garmin visual approach does not guarantee terrain or obstacle clearance. Therefore, when a visual approach is selected, the message OBSTACLE CLEARANCE IS NOT PROVIDED FOR VISUAL APPROACHES is displayed on the approach selection page and must be acknowledged before the visual approach is loaded into the flight plan.

The TAWS function normally provides some elimination of terrain alerts when flying an approach with vertical guidance. The TAWS logic is adjusted to ensure that there is no elimination of terrain alerts while flying a VISUAL approach.

VISUAL approaches are intended to be used as an aid to situational awareness. VISUAL approaches are advisory in nature and do not guarantee terrain and obstacle clearance for the approach runway.

Optional equipment

For optional equipment such as stormscope, SVS or TAWS, refer to section 9 Supplements.

Other optional equipment such as radio altimeter or chartview system or TAS are described in the GARMIN Pilot's Guide.

• NOTE •

Refer to section 2 Limitations for chartview system operating limitations.

•

Intentionally left blank

Section 8

Handling, servicing and maintenance

Table of contents

8.1	-	General	8.1.1
8.2	-	Identification plate	8.2.1
8.3	-	Publications	8.3.1
8.4	-	Inspection periods	8.4.1
8.5	-	Alterations or repairs	8.5.1
8.6	-	Ground handling	8.6.1
		Towing	8.6.1
		Parking	8.6.1
		Tie-down	8.6.2
		Jacking	8.6.4
		Leveling	8.6.4
		Flyable storage	8.6.4
		Long term storage without flying	8.6.4
8.7	-	Servicing	8.7.1
		Maintenance	8.7.1
		Engine oil	8.7.1
		Fuel	8.7.2
		Landing gear	8.7.7
		Oxygen	8.7.8
8.8	-	Airplane cleaning and care	8.8.1
		Windshield and windows	8.8.1
		Painted surfaces	8.8.1
		Propeller care	8.8.2
		Engine care	8.8.2
		Interior care	8.8.2
8.9	-	Preparation of the airplane (equipment and furnishings)	8.9.1

8.10 - Utilization by cold weather (- 0°C to - 25°C)
or very cold weather (- 25°C to - 40°C) 8.10.1

8.1 - General

This section contains the procedures recommended by the manufacturer for the proper ground handling and routine care and servicing of airplane. Also included in this section are the inspection and maintenance requirements which must be followed if your airplane is to retain its performance and dependability.

It is recommended that a planned schedule of lubrication and preventive maintenance be followed, and that this schedule be tailored to the climatic or flying conditions to which the airplane is subjected.

For this, see manufacturer maintenance manual.

Intentionally left blank

8.2 - Identification plate

Any correspondence regarding your airplane should include its serial number. This number together with the model number, type certificate number and production certificate number are stamped on the identification plate attached to the left side of the fuselage beneath the horizontal stabilizer.

Intentionally left blank

8.3 - Publications

When the airplane is delivered from the factory, it is supplied with a POH, the GARMIN Integrated Flight Deck Pilot's Guide and supplemental data covering optional equipment installed in the airplane (refer to section 9 Supplements and pilot guides).

In addition, the owner may get access to the following publications online :

- Maintenance Manual
- Illustrated Parts Catalog
- Catalog of Service Bulletins, Service Letters

▲ CAUTION ▲

POH must always be in the airplane.



Intentionally left blank

8.4 - Inspection periods

Refer to regulations in force in the certification country for information concerning preventive maintenance to be carried out.

A maintenance manual must be obtained prior to performing any preventive maintenance to make sure that proper procedures are followed. Maintenance must be accomplished by licensed personnel.

Intentionally left blank

8.5 - Alterations or repairs

It is essential that the airworthiness authorities be contacted prior to any alterations or repairs on the airplane to make sure that airworthiness of the airplane is not violated. Alterations or repairs must be accomplished by licensed personnel.

Intentionally left blank

8.6 - Ground handling

▲ CAUTION ▲

Only move or tow the airplane with someone in the cockpit.



Towing

▲ CAUTION ▲

Using the propeller for ground handling could result in serious damage, especially if pressure or pull is exerted on blade tips.



The airplane should be moved on the ground with a towing bar and a suitable vehicle in order not to damage the nose gear steering mechanism. Nose gear fork is equipped with an integrated towing fitting.

▲ CAUTION ▲

Do not tow the airplane when controls are secured.

When towing with a vehicle, do not exceed the nose gear turning angle, as this may result in damage to the gear and steering mechanism
- see figure 8.6.1



Parking

When parking the airplane, head it into the wind. Do not set the parking brake when brakes are overheated or during cold weather when accumulated moisture may freeze the brakes. Care should be taken when using the parking brake for an extended period of time during which an air temperature rise or drop could cause difficulty in releasing the parking brake or damage the brake system.

Make sure that the FUEL TANK SELECTOR is set to OFF.

● NOTE ●

Do not use solar screens or shields installed on the airplane inside, or leave sun visors down against windshield when airplane on ground. The reflected heat from these items causes a temperature increase which accelerates the crack growth or crazing and may cause the formation of bubbles in the inner layer of multilayer windshields.



Beyond 24 hours parking, use windshield protection screen provided with lateral and underside straps.

For long term parking, blanking covers (static ports, pitot, engine air inlet, NACAs, exhaust stubs), cockpit cover, tie-downs, wheel chocks, propeller lock and control lock are recommended.

In severe weather and high wind conditions, tie the airplane down as outlined in the following paragraph.

Tie-down

Proper tie-down procedure is the best protection against damage to the airplane by gusty or strong winds. To tiedown the airplane securely, proceed as follows :

- Install control lock - see figure 8.6.2.
- Chock all wheels.
- Tie sufficiently strong ropes or chains to hold airplane down ; insert a rope in each tie-down hole located on flap hinge arm ; secure each rope to a ramp tie-down or to mooring rod.
- Check that doors are closed and locked.



Figure 8.6.1 - Turning angle limits

Jacking

When it is necessary to jack the airplane off the ground, refer to maintenance manual for specific procedures and equipment required.

Leveling

Level the airplane as described in maintenance manual.

Flyable storage (below 28 days)

Airplanes placed in storage for a maximum of 28 days are considered in flyable storage.

Storage from 0 to 7 days :

- Engine : according to maintenance manual P & W C.

Airplane fueling :

- Keep fuel tanks full to minimize condensation in the tanks. Keep the battery fully charged to prevent the electrolyte from freezing in cold weather.
Close oxygen cylinder isolation valve.

Storage from 8 to 28 days :

- Engine : according to maintenance manual P & W C.

Airplane fueling :

- Keep fuel tanks full to minimize condensation in the tanks. Keep the battery fully charged to prevent the electrolyte from freezing in cold weather.
Close oxygen cylinder isolation valve.

Battery, remaining in the airplane or removed :

- Disconnect battery and check its charge level at regular intervals.

Long term storage without flying (over 28 days)

Refer to maintenance manual for the procedures to follow.

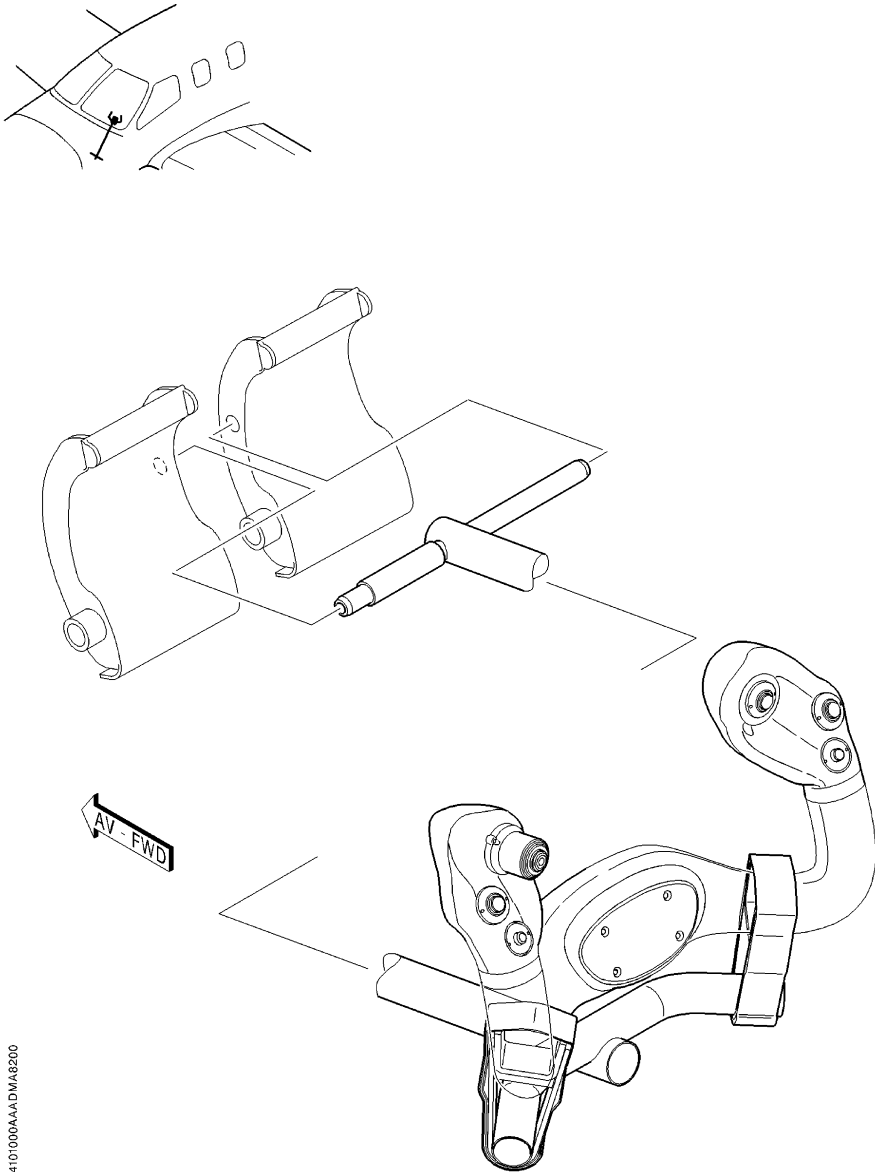

14101000AAAADMA8200

Figure 8.6.2 - Control lock device

Intentionally left blank

8.7 - Servicing

Maintenance

In addition to the preflight inspection, refer to section 4, Normal procedures, servicing, inspection and test requirements for the airplane are detailed in the maintenance manual.

Maintenance manual outlines all items which require servicing, inspection, testing or overhaul.

Engine oil

Type of oil

▲ **CAUTION** ▲

Do not mix different viscosities or specifications of oil as their different chemical structure can make them incompatible.



Specification

Nominal Viscosity	Specification	NATO Code
5cSt	MIL-PRF-23699G	O-156 (STD)
		O-154 (HTS)

Figure 8.7.1 - Recommended engine oil types

Reference : Service Bulletin P & W C. No. 14001 at the latest revision

Oil capacity

System total capacity :

12.7 Quarts (12 Litres) (oil cooler included)

Usable capacity :

6 Quarts (5.7 Litres)

Servicing

The engine oil should be changed and the oil filter cleaned/replaced at intervals recommended in Pratt & Whitney Canada Engine Maintenance Manual (EMM) (Ref. chapter 72-00-00, table 601, periodic inspection).

Oil level check

To avoid overfilling of oil tank, and high oil consumption, an oil level check is recommended within 30 minutes after engine shutdown. Ideal interval is 15 to 20 minutes. If more than 30 minutes have passed and the dipstick indicates that oil is needed, start the engine and run at LO-IDLE for five minutes, and recheck oil level.

Check oil level against marking on dipstick and top-up as required. Normal oil level is between MAX HOT and one US quart (0.83 Imp. Quart, 0.95 litres) below MAX HOT, with engine in horizontal attitude.

● NOTE ●

Filling the oil to the maximum level may result in high consumption rate, with the oil exiting through the accessory gearbox breather.



▲ CAUTION ▲

When filler cap assembly is installed and locked, no movement is allowed.



Fuel

Total capacity each tank : 150.5 USG (570 l).

● NOTE ●

To minimize condensation, it is recommended that airplane be refueled after each flight, respecting weight and balance limits.



▲ CAUTION ▲

Never fly the airplane with contaminated (water, sand, rust, dust...) or unapproved fuel



Before each flight and after each fueling, use a sampler to bleed off some fuel through each tank and fuel filter drain to detect possible contamination and be sure that fuel used is the proper quality. If contamination is present, continue draining through all draining points until fuel is free of contamination. If quality of fuel used is not correct, defuel airplane completely and refuel with proper quality fuel.

▲ WARNING ▲

During all fueling operations, fire fighting equipment must be available ; attach grounding wire to an unpainted metallic part of the airplane.

Do not operate any avionics or electrical equipment on the airplane during fueling. Do not allow open flame or smoking in the vicinity of the airplane while fueling.



▲ CAUTION ▲

During fueling operations, take care not to damage pneumatic deicer boots located on wing leading edge.

The use of aviation gasoline (AVGAS) must be restricted to emergencies only. AVGAS will not be used for more than 150 cumulative hours during any period between engine overhaul.



• NOTE •

Use of AVGAS must be recorded in engine module logbook.



US Specification (US)	French Specification (FR)	English Specification (UK)	NATO Code
ASTM-D1655 JET A ASTM-D1655 JET A1 ASTM-D1655 JET B	AIR 3405C Grade F35	DERD 2494 Issue 9	F35 without additive
MIL-DTL-5624 Grade JP-4	AIR 3407B	DERD 2454 Issue 4 Amdt 1	F40 with additive
MIL-DTL-5624 Grade JP-5	AIR 3404C Grade F44	DERD 2452 Issue 2 Amdt 1	F44 with additive when utilization
MIL-DTL-83133 Grade JP-8	AIR 3405C Grade F34	DERD 2453 Issue 4 Amdt 1	F34 with additive S748
	AIR 3404C Grade F43	DERD 2498 Issue 7	F43 without additive

Figure 8.7.2 - Recommended fuel types
Reference : Service Bulletin P & W C. No. 14004

Fuel additives

Fuel used must contain an anti-ice additive conforming to MIL-I-27686 or MIL-I-85470 specification.

Strict adherence to recommended preflight draining instructions as called for in Section 4 will eliminate any free water accumulations from the tank sumps. While small amounts of water may still remain emulsified in the gasoline, it will normally be consumed and go unnoticed in the operation of the engine.

One exception to this can be encountered when operating under the combined effect of use of certain fuels, with high humidity conditions on the ground followed by flight at high altitude and low temperature. Under these unusual conditions, small amounts of water emulsified can precipitate from the fuel stream and freeze in sufficient quantities to induce partial icing of the engine fuel system.

While these conditions are quite rare and will not normally be a problem to owners and operators, they do exist in certain areas of the world and consequently must be dealt with, when encountered.

Therefore, to alleviate the possibility of fuel icing occurring under these unusual conditions, it is required to add an ethylene glycol monomethyl ether (EGME or DIEGME) compound to the fuel supply.

The introduction of an EGME or DIEGME compound into the fuel provides two distinct effects :

- it absorbs the dissolved water from the fuel
- alcohol has a freezing temperature depressant effect.

EGME or DIEGME must be carefully mixed with the fuel in concentration, it must be between a minimum of 0.06 % and a maximum of 0.15 % by volume. Figure 8.7.3 provides EGME or DIEGME / fuel mixing ratio information.

▲ CAUTION ▲

Do not permit the concentrate of EGME or DIEGME to come in contact with the airplane finish or fuel tank

Mixing of the EGME or DIEGME with the fuel is extremely important. An excessive concentration (greater than 0.15 % by volume maximum) will result in detrimental effects to the fuel tanks by deterioration of protective primer, sealants and seals of system and engine components. Use only blending equipment recommended by the manufacturer to obtain proper proportioning.



Prolonged storage of the airplane will result in a water buildup in the fuel which leeches out the additive. An indication of this is when an excessive amount of water accumulates in the fuel tank sumps. The concentration can be checked using a differential refractometer. It is imperative that the technical manual for the differential refractometer be followed explicitly when checking the additive concentration.

Fuel and fuel additives in Ukraine and CIS countries

It is possible to use kerosene GOST 10227 RT with addition of anti-icing liquid :

- liquid II - GOST 8313-88

Above-mentioned liquid is added in the quantity equal to 0.3 percent per volume.

▲ CAUTION ▲

Refer to Service Bulletin P & WC No. 14004 at its latest revision for appropriate quantities.



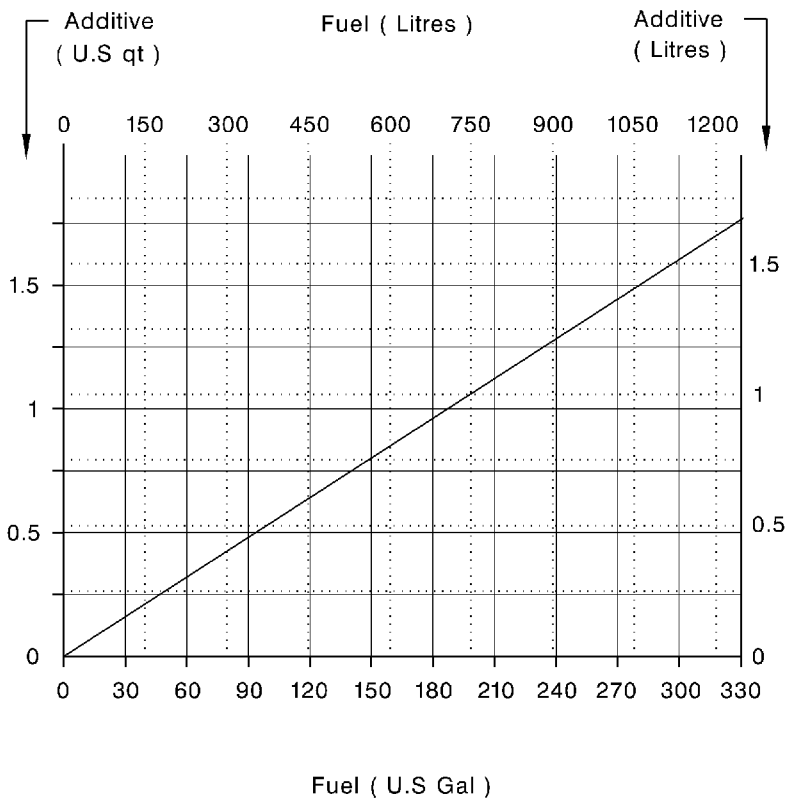

I4284000\AA\AEMA8000

Figure 8.7.3 - Additive mixing ratio (EGME or DIEGME)

Landing gear

Nose gear tire

5.00-5 10 PR - Inflation pressure : 98 psi (6.7 bars) *

Main gear tires

18 5.5 10 PR - Inflating pressure : 135 psi (9.32 bars) *

Nose gear shock absorber

Fill with hydraulic fluid AIR 3520 B (MIL.H5606E) ; inflate with nitrogen to 87 psi (6 bars).

Main gear shock absorbers

Fill with hydraulic fluid AIR 3520 B (MIL.H5606E) ; inflate with nitrogen to 160 psi (11 bars).

Hydraulic system

Check every 100 hours and service with AIR 3520 B (MIL.H5606E) hydraulic fluid.

Brakes

Service as required with AIR 3520 B (MIL.H5606E) hydraulic fluid.

● NOTE ●

A higher inflation pressure has to be applied to tires and shock absorbers when in very cold conditions - refer to chapter 8.9.

●

- (*) Tire inflation pressures are given for an airplane on ground at 21° C.
An ambient temperature change of 3° C produces approximately 1 % pressure change.

Oxygen

The oxygen replenishment device is installed directly on the oxygen cylinder head. It consists of a charging valve and a pressure gauge graduated from 0 to 2000 PSIG. A chart - see figure 8.7.4, located on the inside of the cylinder service door, gives the maximum cylinder charge pressure for the ambient temperature.

I4112400AAAAM/A8000

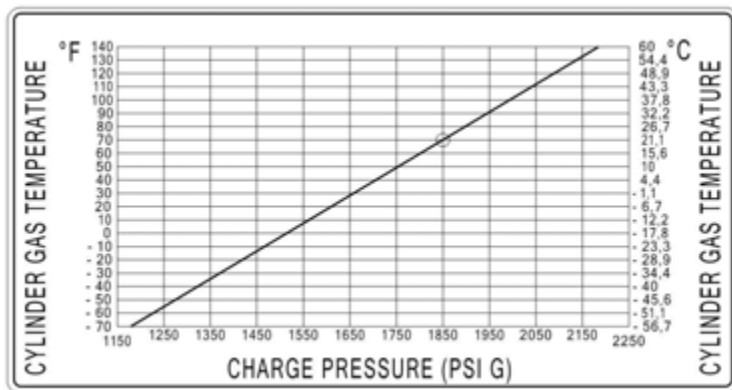

Figure 8.7.4 - Charge pressure chart

Replenishment procedure**▲ WARNING ▲**

Make sure that the airplane is fitted with a grounding cable and is properly grounded.

The oxygen cart must be electrically bonded to the airplane.

Do not operate the airplane electrical switches or connect/disconnect ground power during oxygen system replenishment.

Do not operate the oxygen system during refueling/defueling or perform any other servicing procedure that could cause ignition.

Introduction of petroleum based substances such as grease or oil to oxygen creates a serious fire hazard. Use no oil or grease with the oxygen replenishment equipment.

Always open the shut-off valve slowly to avoid generating heat, and replenish the system slowly at a rate not exceeding 200 PSIG (13.7 bars) per minute.

**▲ CAUTION ▲**

Replenishment of the oxygen system should only be performed by qualified personnel.

**● NOTE ●**

The cylinder is fully charged at a pressure of 1850 PSIG (127 bars) at a temperature of 70° F (21° C). If the cylinder temperature differs from 70° F (21° C), refer to figure 8.7.4 - which lists the required pressures according to the cylinder temperature.



- 1 - Open the oxygen service door at the rear of the right wing fairing.
- 2 - Measure the oxygen cylinder temperature.
- 3 - Make sure the thermometer indication is constant. Note the indication.
- 4 - Refer to the temperature/pressure chart for the correct oxygen cylinder pressure.

If the pressure on the oxygen cylinder gauge is lower than the maximum for the cylinder temperature :

Fill the oxygen cylinder.

The minimum pressure for the oxygen cylinder is 217 PSIG (15 bars).

▲ CAUTION ▲

If the oxygen cylinder pressure falls below the minimum, the cylinder must be purged before refilling.
Inform maintenance department.



- 5 - Make sure the area around the oxygen cylinder charging valve is clean. Remove the cap from the charging valve.
- 6 - Make sure the oxygen supply hose is clean, and connect it to the charging valve.
- 7 - Slowly pressurize the oxygen cylinder to the correct pressure.
- 8 - Close the oxygen supply and allow the cylinder temperature to become stable.
- 9 - Monitor the oxygen pressure on the gauge and fill to the correct pressure if necessary.
- 10 - Release the pressure in the oxygen supply hose and disconnect from the charging valve.
- 11 - Install the cap on the charging valve.
- 12 - Make sure all the tools and materials are removed and the work area is clean and free from debris.
- 13 - Close the oxygen service door.

Passenger masks repacking instructions**▲ CAUTION ▲**

Do not use oil or other petroleum based lubricants on passenger oxygen mask or deployment container. Oil based lubricants are a fire hazard in oxygen-rich environments.

Repacking procedures shall be performed by personnel familiar with the instructions and warnings in this document. Improperly packed masks can damage the masks or result in failure of the masks to deploy.

**▲ WARNING ▲**

Masks shall be repacked in an area free of oil, grease, flammable solvents or other contaminants.



- 1 - Inspect and disinfect mask and deployment container with an aqueous solution of Zephiran Chloride (Scott Aviation P/N 00-2572) or with disinfection cleaners (EROS P/N SAN50). After disinfecting and thoroughly drying the mask, lightly dust the outside of the facepiece with Neo-Novacite powder (Scott Aviation P/N 00-736). Contamination can be removed with mild soap and water solution.
- 2 - Fold headstrap into facepiece. Pull lanyard cord out to side of facepiece so that it does not interfere with repacking.
- 3 - Lay reservoir bag on flat surface and smooth out wrinkles.

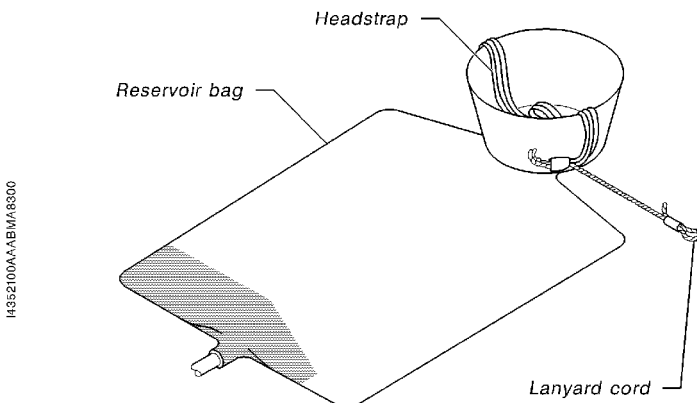

- 4 - Gently fold reservoir bag lengthwise into thirds (outside edges folded inward over center of bag). Do not crease bag.

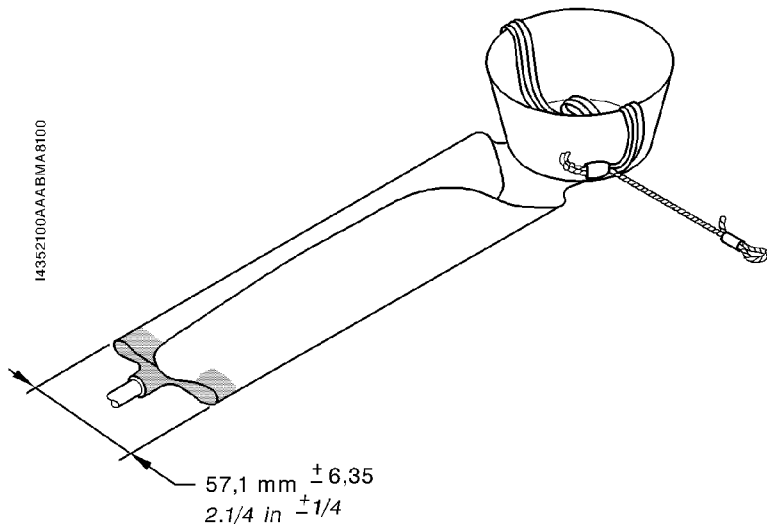

- 5 - Fold reservoir bag away from breathing valves and into facepiece. Make sure bag does not cover breathing valves.

Top view

Bottom view

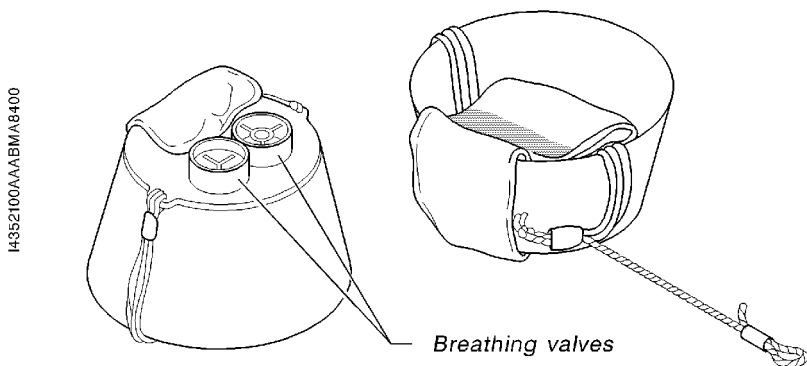

- 6 - Coil oxygen tubing inside facepiece over reservoir bag.

M4352100AAAABMA18000

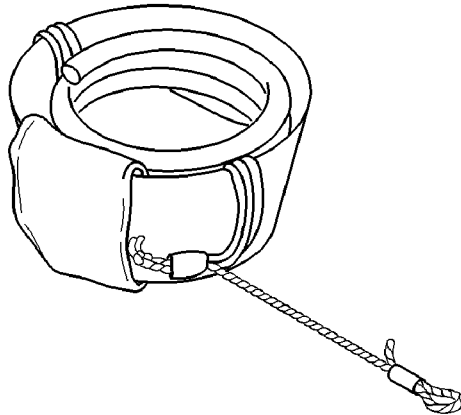

- 7 - Connect oxygen tubing to manifold oxygen fitting.

▲ WARNING ▲

Make sure lanyard pin is inserted into correct check valve for mask being installed. Cross connected pins will result in passengers pulling lanyard cords only to initiate oxygen flow to another mask.



- 8 - Insert lanyard pin into corresponding check valve.
- 9 - Place mask facepiece - first in deployment container. Make sure that oxygen tubing and lanyard cord are free to deploy and are not caught between the container and lid.
- 10 - Close and latch deployment container lid.

Intentionally left blank

8.8 - Airplane cleaning and care

Windshield and windows

The windshield and windows should be cleaned with an airplane windshield cleaner.

● NOTE ●

Refer to the maintenance manual for products and procedures to apply.



Apply the cleaner sparingly with soft cloths and rub with moderate pressure until all dirt, oil scum and bug stains are removed. Allow the cleaner to dry, then wipe it off with soft flannel cloth.

▲ CAUTION ▲

Do not use any of the following products on, or for cleaning windows :
methanol, methylated alcohol, gasoline, benzene, xylene,
methyl-ethyl-ketone, acetone, carbon tetrachloride, lacquer paint
thinners, commercial or household window cleaning sprays. In case of
doubt concerning a product, do not use it.

During cleaning operation, avoid wearing objects such as ring, watch,
bracelet and exercise care to prevent buttons, buckles and any hard
objects from touching the windshield and the windows.

Adhesive tapes other than Minnesota 3m type 670 shall not be used on
acrylic surfaces.

Never use buffing machines as excessive forces or speeds might
produce redhibitory defects.



Follow by carefully washing with a mild detergent and plenty of water. Rinse
thoroughly, then dry with a clean moist chamois. Do not rub the plastic with a dry cloth
since this builds up an electrostatic charge which attracts dust. Waxing will finish the
cleaning operation. A thin, even coat of wax polished out by hand with clean soft
flannel cloth will fill in minor scratches and help prevent further scratching.

Do not use a canvas cover on the windshield unless freezing rain or sleet is
anticipated since the cover may scratch the plastic surface.

Painted surfaces

Refer to maintenance manual for the products and procedures to apply.

Propeller care

Preflight inspection of propeller blades for nicks and cleaning them occasionally with a cloth soaked with soapy water to clean off grass and bug stains will assure long blade life. Never use an alkaline cleaner on the blades ; remove grease and dirt. Refer to maintenance manual for the procedures to follow.

Engine care

Refer to maintenance manual for the procedures to follow.

Interior care

To remove dust and loose dirt from the upholstery and carpet, clean the interior regularly with a vacuum cleaner.

For additional information, refer to maintenance manual.

8.9 - Preparation of the airplane (equipment and furnishings)

▲ WARNING ▲

For all cabin layouts, make sure that access to emergency exit is free at all times.



▲ CAUTION ▲

Removed equipment items must be stored in a manner that ensures their integrity.



Numerous cabin layout configurations are authorized by airplane manufacturer. They are outlined in section 7.

This procedure specifies how to change the 6-seat layout into a 4-seat configuration, and vice versa. Also, it can be used partly to remove or install equipment items.

However, it is the pilot's responsibility to ensure that all necessary authorizations are obtained from the appropriate regulatory authority.

1 - Conversion of 6-seat accommodation into 4-seat accommodation - see figures 8.9.1, 8.9.2, 8.9.3 and 8.9.4

A - Tools and consumable materials

- Seat protective covers

B - Preparation

- 1) Make sure the SOURCE selector is set to OFF and the crash lever is down.

C - Removal of rear seats - see figure 8.9.1

- 1) To remove rear seats, perform the following operations

▲ CAUTION ▲

To prevent damage to seat cushion covers, protective covers should be put on the seats.



- a) Install protective covers.

- b) Unlock backrest using backrest tilting handle (6) and fold it forward.

● NOTE ●

For the R.H. rear seat, backrest tilting handle is located behind backrest.



- c) Unlock seat using seat tilting handle (1) and tilt it forward.

■ >> *Airplane with seats heaters system (Post-MOD70-0588-25)*

▲ CAUTION ▲

Make sure to disconnect the seat heating system before the removal of the seat to prevent harness damage.



- d) Disconnect heating system harness, and clip the loose connector to the holder located on the seat structure.

■ >> *All*

- e) Clear the carpet from under the seat to facilitate moving in rails.

■ >> *Airplane with seats heaters system (Post-MOD70-0588-25)*

- f) Open the floor hatch and clip the second loose connector to the holder located under floor panel. Close the floor hatch.

■ >> *All*

- g) Hold the seat in tilted position and unscrew quick links (7) of strap (9) located under L.H. seatpan.

● NOTE ●

This operation is specific to L.H. seat.



- h) Pull up and hold L.H. and R.H. rings (2), and turn knobs (8) by 90° in order to release and keep locks (3) in up position.
- i) Move the seat in the rails to line up pads (4) with rail (5) apertures.
- j) Remove the seat.

● NOTE ●

Ensure proper storage of strap (9) with L.H. rear seat to avoid losing part.



D - Removal of intermediate seats - see figures 8.9.2 and 8.9.3

- 1) To remove intermediate seats, perform the following operations
 - a) Install protective covers.
 - b) Pull backrest bottom upholstery (25) to remove it.

■ >> *Airplane with seats heaters system (Post-MOD70-0588-25)*

▲ **CAUTION** ▲

Make sure to disconnect the seat heating system before the removal of the seat to prevent harness damage.



- c) Disconnect heating system harness and clip the loose connector to the holder located on the seat structure.

■ >> *All*

- d) Clear the carpet from under the seat to facilitate moving in rails.

■ >> *Airplane with seats heaters system (Post-MOD70-0588-25)*

- e) Open the floor hatch and clip the second loose connector to the holder located under floor panel. Close the floor hatch.

■ >> *All*

- f) Pull up locking handle (21) located under the pan, on the seat rear side, to unlock it.
- g) Move the seat in the rails to line up pads (23) with rail (24) apertures.
- h) Remove the seat.
- i) Install backrest bottom upholstery (25).

▲ **CAUTION** ▲

In order to prevent deflectors damage, it is necessary to remove them.



- 2) Remove deflector (34) maintained with Velcro-type strap.
- 3) If necessary, remove the cabin central carpet.

● NOTE ●

If one of two cargo nets must be installed, it is necessary to use the carpet with appropriate cuttings.



E - Removal of a cabinet

● NOTE ●

This operation must be carried out by a service center.

●

F - Cabin comfort - see figure 8.9.3

- 1) Blank off the hot air outlet, located forward the large door, with blanking device assy (33) stored in storage bag - see figure 8.9.3 detail A.
- 2) Remove blanking plugs (32) located forward the large door and store them into storage bag - see figure 8.9.3 detail B.
- 3) Remove blanking plugs (31) located in line with R.H. front side window - see figure 8.9.3 detail C, and install them on holes located in line with card table - see figure 8.9.3 detail D.

● NOTE ●

Should long term changes be made to cabin configuration (4 / 6 seats), cabin upholstery blanking device and plug arrangements will need to be reconfigured in order to optimize the temperature conditioning system.

Subject changes should preferably be performed at a recognized service center.

●

G - Installation of intermediate seats - see figures 8.9.2, 8.9.3 and 8.9.4

- 1) Install deflector (34), ensuring that both red marks (36) are aligned with the deflector holes (35) - see figure 8.9.4.

● NOTE ●

Position deflectors (34) as indicated on label, according to future position of intermediate seat, in order to optimize cabin cooling.

●

- 2) Install intermediate seats.

● NOTE ●

If seats are installed facing flight direction (forwards), the L.H. seat must be installed on the right and the R.H. seat on the left in order to have the armrest on aisle side.

●

- a) Pull backrest bottom upholstery (25) to remove it.
- b) Clear the carpet from seat area to facilitate moving in rails.

- c) Position the seat and put lock (22) near the color mark (37) made on rail bottom on aisle side.

● NOTE ●

The color mark (37) in the rail is aligned with red marks (36).



■ >> *Airplane with seats heaters system (Post-MOD70-0588-25)*

- d) Open the floor hatch and remove clip from holder located under floor panel and connect heating system harness (26). Clip connectors on the holder located on the seat structure.

■ >> *All*

- e) Pull up locking handle (21), insert pads (23) into rail (24) apertures and then, move the seat so that lock (22) is in front of the color mark (37).
- f) Release locking handle (21) to lock the seat.

▲ **WARNING** ▲

Verify that lock (22) and all pads (23) are engaged and locked into rails, trying to move seat forward and backward.



- g) Install backrest bottom upholstery (25).

● NOTE ●

Adjust it properly; make sure not to obstruct deflector (34) outlet.



- h) Slide properly the carpet under the seat.
- i) Remove protective covers.

H - Final operations

- 1) If removed, install cabin central carpet suited to the intended use.

● NOTE ●

Slide properly the carpet under doorstep.



- 2) If necessary, remove the baggage compartment partition net and install the small or large cargo net - refer to section 7.
- 3) Make sure the work area is clean and free from debris.
- 4) Determine weight and balance - refer to section 6.

2 - Conversion of 4-seat accommodation into 6-seat accommodation - see figures 8.9.1, 8.9.2, 8.9.3 and 8.9.4

A - Tools and consumable materials

- Seat protective covers

B - Preparation

- 1) Make sure the SOURCE selector is set to OFF and the crash lever is down.
- 2) If installed, remove the cargo net.
- 3) Remove intermediate seats – refer to paragraph 1.D.
- 4) Remove the deflectors (34) maintained with Velcro-type strap.
- 5) If necessary, remove the cabin central carpet.

C - Cabin comfort - see figure 8.9.3

- 1) Remove blanking plugs (32) from their storage bag and install them on holes located forward the large door - see figure 8.9.3 detail B.
- 2) Remove blanking device assy (33) from the hot air outlet, located forward the large door, and store it into storage bag - see figure 8.9.3 detail A.
- 3) Remove blanking plugs (31) located in line with card table - see figure 8.9.3 detail D, and install them on holes located in line with R.H. front side window - see figure 8.9.3 detail C.

● NOTE ●

Should long term changes be made to cabin configuration (4 / 6 seats), cabin upholstery blanking device and plug arrangements will need to be reconfigured in order to optimize the temperature conditioning system.

Subject changes should preferably be performed at a recognized service center.

●

D - Installation of cabinet

● NOTE ●

This operation must be carried out by a service center.

●

E - Installation of intermediate seats

- 1) Install intermediate seats – refer to paragraph 1 G.
- 2) If removed, install the baggage compartment partition net.
- 3) If removed, install cabin central carpet.

F - Installation of rear seats - see figure 8.9.1

- 1) Make sure the work area is clean and free from debris.
- 2) Clear the carpet from seat area to facilitate moving in rails.
- 3) Check that knobs (8) maintain locks (3) in up position.
- 4) Position the seat, fold it forward, refer to detail B, and insert pads (4) into rail (5) apertures.
- 5) Move the seat so that locks (3) are in front of the color mark made on rail bottom.
- 6) Pull up and hold L.H. and R.H. rings (2) and turn knobs (8) by 90° in order to insert locks (3) into rail (5) apertures.
- 7) Make sure the seat is correctly locked on rails (5).
- 8) Tilt seat forward, hold it and slip strap (9) around the locking control hinge pin. Screw quick links (7).

■ >> *Airplane with seats heaters system (Post-MOD70-0588-25)*

- 9) Open the floor hatch and remove clip from holder located under floor panel and connect heating system harness (26). Clip connectors on the holder located on the seat structure.

■ >> *All*

- 10) Tilt the seat rearward and lock it using seat tilting handle (1).
- 11) Fold up the backrest and lock it using backrest tilting handle (6).
- 12) Slide properly the carpet under the seat.
- 13) Remove protective covers.

G - Reconditioning

- 1) Make sure the work area is clean and free from debris.
- 2) Determine weight and balance - refer to section 6.

3 - Additional configurations

▲ WARNING ▲

Removed seats can only be reinstalled at their original locations. Rear seats (L.H. or R.H.) are the only ones that can be installed in the rear seat zone along the cabin axis on both central rails. Refer to section 7.



• NOTE •

Numerous cabin layout combinations involving the seats (rear and intermediate) are authorized, and can be performed by the pilot or service centers ; installation arrangements with cabinet(s) are to be performed by service centers only.

However, it is the pilot's responsibility to ensure that all necessary authorizations are obtained from the appropriate regulatory authority.



• NOTE •

To remove or install these elements, use paragraph 1 or 2. Refer to table 1.



• NOTE •

After these operations, determine the weight and balance. Refer to section 6.



Equipment	Action	Description operation
Rear seat	Removal	Paragraph 1.C.
	Installation	Paragraph 2. F.
Intermediate seat	Removal	Paragraph 1.D.
	Installation	Paragraph 1.G.
Cargo net	Installation	Section 7

Table 1

Intentionally left blank

- 1) Seat tilting handle
- 2) Ring
- 3) Lock
- 4) Pad
- 5) Rail
- 6) Backrest tilting handle
- 7) Quick link
- 8) Knob
- 9) Strap
- 10) Seats heaters connector, if installed

Figure 8.9.1 (1/2) - Removal / installation of rear seat

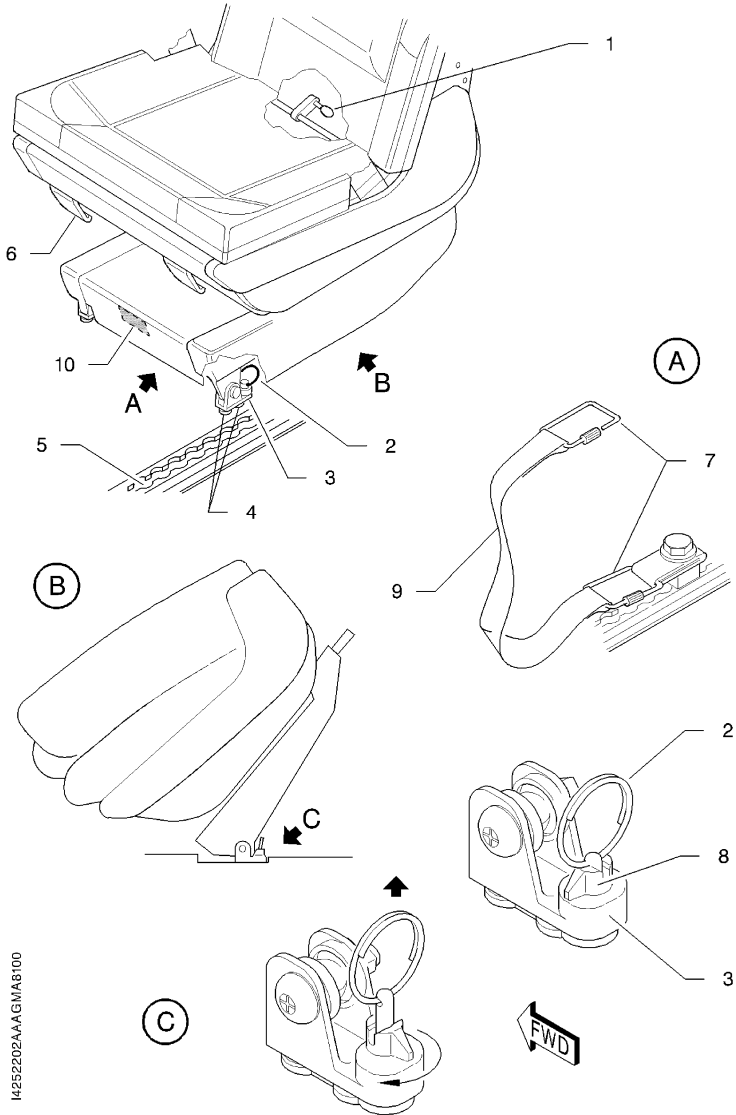

1425202AAAGM/A6100

Figure 8.9.1 (2/2) - Removal / installation of rear seat

- 21) Locking handle
- 22) Lock
- 23) Pad
- 24) Rail
- 25) Backrest bottom upholstery
- 26) Seats heaters connector
(if installed)

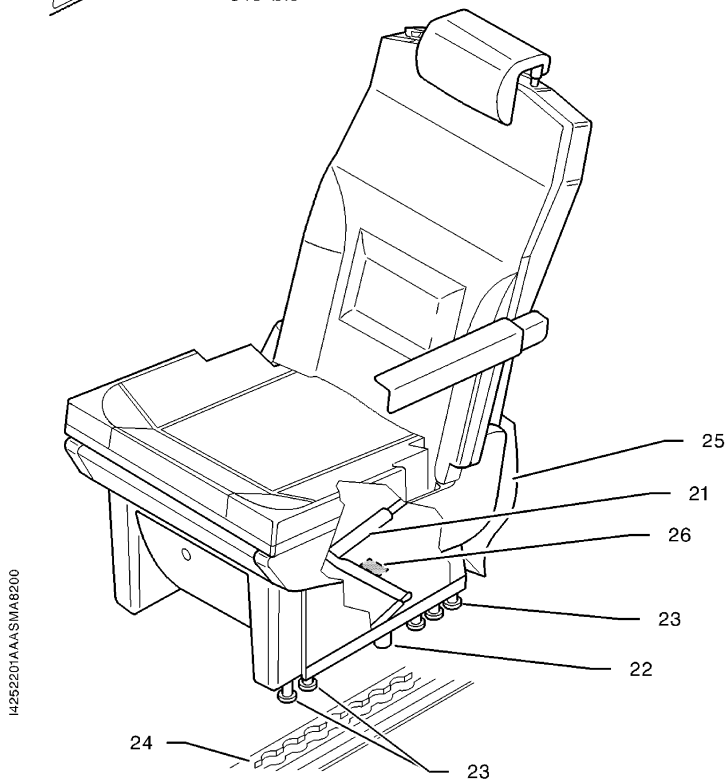
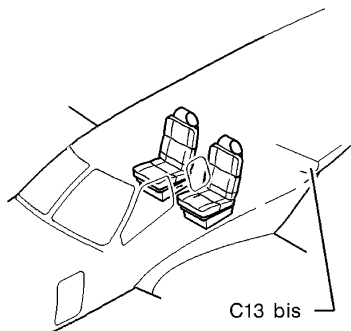

Figure 8.9.2 - Removal / installation of intermediate seat

- 31) Blanking plug
- 32) Blanking plug
- 33) Blanking device assy
- 34) Deflector

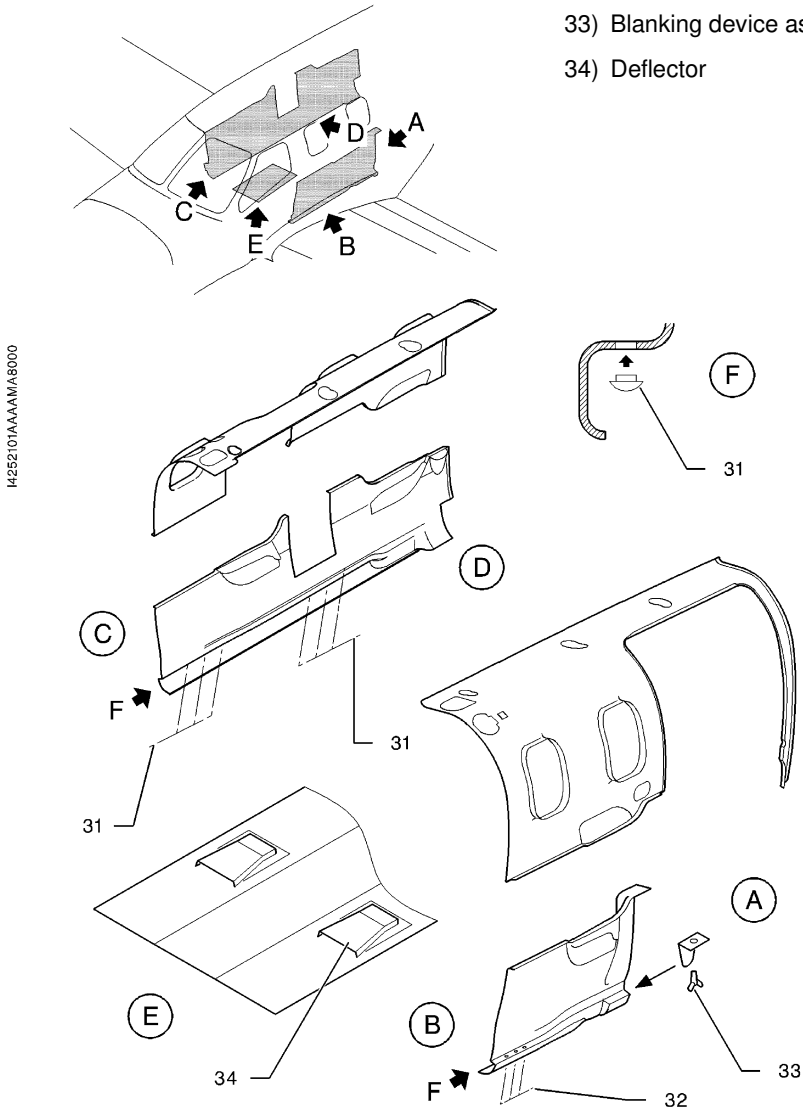

Figure 8.9.3 - Cabin comfort - Installation of blanking plugs and deflector

- 34) Deflector
- 35) Deflector hole
- 36) Red mark
- 37) Color mark

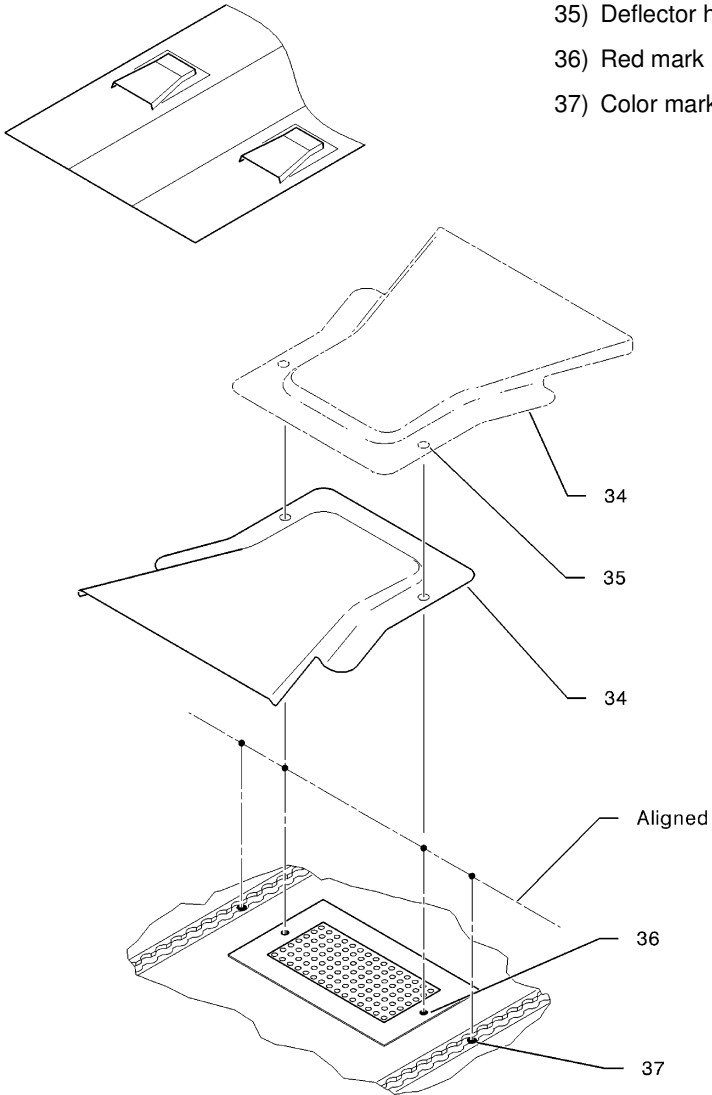

Figure 8.9.4 - Cabin comfort - Installation of deflector

8.10 - Utilization by cold weather (- 0°C to - 25°C) or very cold weather (- 25°C to - 40°C)

● NOTE ●

Check pressure values in a hangar heated at about 15°C with control equipment at room temperature.

●

If a landing is foreseen by cold or very cold weather or in case of airplane prolonged operation in such conditions, it is recommended to prepare the airplane as follows :

- 1 - Smear with silicone grease the door and engine cowlings seals, as well as the leading edge deicers.
- 2 - Apply engine oil on the engine cowling latches.
- 3 - Inflate main landing gear shock absorbers to 247 psi (17 bars) at a room temperature of 15°C.
- 4 - Position a 0.59 in (15 mm) shim at the bottom of the piston tube and against forward landing gear half-fork to reduce shock absorber travel. Refill with hydraulic liquid. Remove the shim and inflate shock absorber to 138 psi (9.5 bars) at a room temperature of 15°C.
- 5 - Inflate main landing gear tires to 130 psi (8.96 bars) and nose tire to 102 psi (7 bars) at a room temperature of 15°C.

● NOTE ●

See table 1 hereafter to check pressure values and to inflate tires and shock absorbers.

●

Check pressure values and inflate, if necessary, according to following table 1 during operation in cold weather only :

		OAT (°C)	- 40°	- 30°	- 20°	- 10°	+ 15°
P r e s s u r e s psi (bars)	Main landing gear shock absorber		189 (13)	196 (13.5)	203 (14)	218 (15)	247 (17)
	Nose gear shock absorber		102 (7)	109 (7.5)	116 (8)	123 (8.5)	138 (9.5)
	Main landing gear tire		144 (9.96)	144 (9.96)	130 (8.96)	130 (8.96)	130 (8.96)
	Nose gear tire		94 (6.5)	94 (6.5)	102 (7)	102 (7)	102 (7)

Table 1



TBM 930

With MOD70-0549-00

List of equipment

Report reference NAV No. 34/90-RJ-App 6

The content of this document is the property of DAHER AEROSPACE. It is supplied in confidence and commercial security of its contents must be maintained.

It must not be used for any purpose other than that for which it is supplied, nor may information contained in it be disclosed to unauthorized persons. It must not be reproduced nor transmitted in any form in whole or in part without permission in writing from the owners of the Copyright.

Information in this document is subject to change without notice.

© 2018, 2019, 2020 - DAHER AEROSPACE

All rights reserved

DAHER AEROSPACE

Customer Care

65921 TARBES CEDEX 9

FRANCE

Printed in FRANCE

PIM - DO NOT USE FOR FLIGHT OPERATIONS

List of effective pages and validities
Edition 1 of January 15, 2018
Airplane equipped with MOD70-0549-00

Page No.	Edit./Rev. No.	Rev. Date	Page No.	Edit./Rev. No.	Rev. Date
■ Title	1-3	JUN 20	■ 17	1-3	JUN 20
			18	1-3	JUN 20
■ 0A	1-3	JUN 20	19	1-3	JUN 20
0B	1-3	JUN 20	20	1-3	JUN 20
0C	1-0	JAN 18	21	1-3	JUN 20
0D	1-1	APR 18	22	1-3	JUN 20
0E	1-2	APR 19	23	1-3	JUN 20
■ 0F	1-3	JUN 20	24	1-3	JUN 20
0G	1-3	JUN 20	25	1-3	JUN 20
■ 0H	1-3	JUN 20	26	1-3	JUN 20
			27	1-3	JUN 20
■ 1	1-3	JUN 20	28	1-3	JUN 20
2	1-0	JAN 18	29	1-3	JUN 20
■ 3	1-3	JUN 20	30	1-3	JUN 20
4	1-1	APR 18	31	1-3	JUN 20
■ 5	1-3	JUN 20	32	1-3	JUN 20
6	1-3	JUN 20	33	1-3	JUN 20
■ 7	1-3	JUN 20	34	1-3	JUN 20
8	1-1	APR 18	35	1-3	JUN 20
■ 9	1-3	JUN 20	36	1-3	JUN 20
10	1-3	JUN 20	37	1-3	JUN 20
11	1-3	JUN 20	38	1-3	JUN 20
12	1-3	JUN 20	39	1-3	JUN 20
13	1-3	JUN 20	40	1-3	JUN 20
14	1-3	JUN 20	41	1-3	JUN 20
15	1-3	JUN 20	42	1-3	JUN 20
■ 16	1-3	JUN 20	■ 43	1-3	JUN 20

Page No.	Edit./Rev. No.	Rev. Date	Page No.	Edit./Rev. No.	Rev. Date
44	1-3	JUN 20			
45	1-3	JUN 20			
46	1-3	JUN 20			
47	1-3	JUN 20			
48	1-3	JUN 20			
49	1-3	JUN 20			
50	1-3	JUN 20			

List of amendments

Revision 0 dated January 15, 2018

Pages	Description
All pages	Creation

List of amendments

Revision 1 dated April 3, 2018

Pages	Description
Title	Change of legal entity name from SOCATA SAS to DAHER AEROSPACE
0A	List of effective pages and validities
0D	List of amendments Revision 1
4 thru 42	Removal of equipment manufacturer name

List of amendments

Revision 2 dated April 8, 2019

Pages	Description
Title	Updating of the date on the copyright
0A	List of effective pages and validities
0E and 0F	List of amendments Revision 2
3	Terminology

List of amendments

Revision 3 dated June 15, 2020

Pages	Description
Title	Updating of the date on the copyright
0A, 0B	List of effective pages and validities
0F thru 0H	List of amendments Revision 3
1	Update of page numbers
3	Addition of equipment part numbers for airplanes up to S/N 1215
5	Correction of flow control shut-off valve part number
6	Addition of ground fan 8031A030
9	Addition of antenna C1105-16 Correction of static dischargers data
10	Addition of data for G3000 (MOD70-0476-00) COM systems
10, 11	Addition of data for GMA 36B
11	Update of MOD number for G3000 COM system
12	Addition of Capability to connect a battery charger
13	Addition of Front seats ease covers Relocation of information related to support device on control wheel Addition of Coat hanger (MOD70-0557-25B) Update of Upholstery variants
14, 15	Update of information related to servicing plugs
15	Addition of Pilot door thermal insulation (MOD70-0574-25B) Deletion of Reels Update of belts data
16	Addition of seats data for airplanes up to S/N 1214 Relocation of smoke goggles data
18	Addition of equipped assy. Part number for Roll and Yaw control Update of Stick shaker MOD list
23, 24	Addition of GIA 64W data
24	Update of FASTBOX MOD list
26	Addition of Brake assembly 30-311 (MOD70-0606-32) Addition of Nose tire 070-310-0 (MOD70-0643-32) Addition of Main wheel (Model 40-489) (MOD70-0606-32)
29, 30, 31	Addition of G3000 (MOD70-0476-00) systems
29, 30	Update of MOD number for GDC 72B, GRS 79

List of amendments

Revision 3 dated June 15, 2020 (Cont'd)

Pages	Description
32	Correction of weight for GDUs Update of MOD number for GEA 71B, GIA 64W, GMA 36B, Surface Watch
33	Addition of Stormscope data (34056F) Addition of resourcing radome
34	Deletion of GRA 55 transceiver part number
35	Addition of TAS system data (MOD70-0258-00G) Addition of NAV receiver data integrated in GIA 64W
36, 37	Update of transponders data
39	Addition of MC10 Smart Mike mask
41	Update of Information systems list
45	Correction of arm value for Overspeed governor
47	Addition of Engine controls data
48	Addition of GEA 71B data
7, 17, 19 thru 22, 25, 27, 28, 38, 40, 42 thru 44, 46, 49, 50	Terminology, text moving and/or presentation

Intentionally left blank

Table of contents

	Page
ATA 01 - Specific optional equipment	4
ATA 21 - Environmental system	5
ATA 22 - Auto flight	8
ATA 23 - Communications	9
ATA 24 - Electrical power	12
ATA 25 - Equipment and furnishings	13
ATA 26 - Fire protection	17
ATA 27 - Flight controls	18
ATA 28 - Fuel system	20
ATA 30 - Ice and rain protection	21
ATA 31 - Indicating / recording systems	23
ATA 32 - Landing gears	25
ATA 33 - Lights	27
ATA 34 - Navigation	29
ATA 35 - Oxygen	39
ATA 37 - Vacuum	40
ATA 46 - Information systems	41
ATA 52 - Doors	42
ATA 56 - Windows	43
ATA 57 - Wings	44
ATA 61 - Propeller	45
ATA 71 - Power plant	46
ATA 76 - Engine controls	47
ATA 77 - Engine indicating	48
ATA 79 - Lubrication	49

The following list contains standard equipment installed on each airplane and available optional equipment.

A separate list of equipment of items installed at the factory in your specific airplane is provided in your airplane file.

Columns showing weight (in pounds) and arm (in inches) provide the weight and center of gravity location for the equipment.

In the list of Required, Standard or Optional equipment (not restrictive), a letter "R", "S", "O" or "A" allows classifying the equipment :

- "R" : equipment items required for certification
- "S" : standard equipment items
- "A" : optional equipment items which are in addition to required or standard items
- "O" : optional equipment items replacing required or standard items

Pilot's Operating Handbook

List of critical RVSM equipment

Equipment listed hereafter, or later approved versions, is required for RVSM operation.

>> *Up to S/N 1215*

Equipment	*	**	P/N
Barometric altimeter :			
- GDC74B (Air data computer)	2	2	P/N 011-01110-01
- GDU1200W (Display)	3	2	P/N 011-02333-00
Autopilot Altitude Hold function :			
- GMC710 (AFCS mode controller)	1	1	P/N 011-01020-10
- GIA63W (Integrated Avionics Computer)	2	2	P/N 011-00105-40
- GRS77	2	2	P/N 011-00868-10
ATC transponder :			
- Altitude reporting transponder	1	1	TSO C-74c

>> *From S/N 1216*

Equipment	*	**	P/N
Barometric altimeter :			
- GDC72B (Air data computer)	2	2	P/N 011-03734-40
- GDU1250W (Display)	3	2	P/N 011-04186-00
Autopilot Altitude Hold function :			
- GMC710 (AFCS mode controller)	1	1	P/N 011-01020-10
- GIA64W (Integrated Avionics Computer)	2	2	P/N 011-03711-00
- GRS79	2	2	P/N 011-03732-00
ATC transponder :			
- Altitude reporting transponder	1	1	TSO C-74c

(*) Quantity installed

(**) Quantity required

S/ R/ A/ O	Item OPT70 or MOD70	Required (R) or Standard (S) or Optional (A or O) equipment	Weight per unit lb (kg)	Arm in. (m)
01 - Specific optional equipment				
S	01026A	Flight ceiling at 31000 ft	/	/

S/ R/ A/ O	Item OPT70 or MOD70	Required (R) or Standard (S) or Optional (A or O) equipment	Weight per unit lb (kg)	Arm in. (m)
21 - Environmental system				
S	0454-21A	General Air System Controller (GASC) 82024A040701	1.98 (0.900)	311.02 (7.900)
21-20 - Distribution				
S		Mixing unit 9723A010001	0.53 (0.240)	151.57 (3.850)
S		Hot Air Distributor 6044A010001	4.06 (0.840)	153.54 (3.900)
S		Bleed temperature switch 92244B010002	0.13 (0.060)	153.54 (3.900)
21-30 - Pressurization control				
S		Cabin altitude warn switch 214 C40.3.261	0.077 (0.035)	153.94 (3.910)
S		Cabin differential pressure warn switch 17-600-01	0.143 (0.065)	139.76 (3.550)
S	0448-21	Outflow valve 81144A010101	2.976 (1.350)	317.32 (8.060)
S	0448-21	Safety valve 81145A010101	2.337 (1.060)	317.32 (8.060)
21-50 - Temperature conditioning system				
S		Flow control shut-off valve 6784A010001	4.74 (2.500)	114.17 (2.900)
S		Non-return valve 7085A010002	0.11 (0.050)	102.36 (2.600)

S/ R/ A/ O	Item OPT70 or MOD70	Required (R) or Standard (S) or Optional (A or O) equipment	Weight per unit lb (kg)	Arm in. (m)
S		Shut-off valve 4589A010001	2.37 (1.075)	114.17 (2.900)
S		Intermediate pressure sensor 93557A010001	0.33 (0.150)	110.24 (2.800)
S		Overheat thermal switch A042010300-5	0.18 (0.080)	110.24 (2.800)
S		Main heat exchanger 81249A010001	7.72 (3.500)	108.27 (2.750)
S		Non-return valve 52704A010001	0.66 (0.300)	118.11 (3.000)
S		Ground Fan 8031A020	3.95 (1.790)	90.55 (2.300)
S		Ground Fan 8031A030	3.95 (1.790)	90.55 (2.300)
		21-55 - Vapor cycle cooling system		
S		Compressor 1377A010001	14.77 (6.700)	98.43 (2.500)
S		Cockpit Evaporator Assembly 14720A010001	9.06 (4.111)	200.79 (5.100)
S		Cabin Evaporator Assembly 14719A010001	12.90 (5.850)	311.02 (7.900)
S		Condenser Assembly 81250A010001	24.80 (11.250)	330.71 (8.400)
		21-60 - Temperature regulation		
S		By-pass valve 6043A010001	3.31 (1.500)	106.30 (2.700)
S		Bleed differential pressure sensor 93558A010001	0.44 (0.200)	114.17 (2.900)

S/ R/ A/ O	Item OPT70 or MOD70	Required (R) or Standard (S) or Optional (A or O) equipment	Weight per unit lb (kg)	Arm in. (m)
S		Inlet temperature sensor 93276A010001	0.11 (0.050)	153.54 (3.900)
S		Cockpit ventilated sensor 92279A010002	0.18 (0.080)	182.09 (4.625)
S		Cabin ventilated sensor 92279A010002	0.18 (0.080)	250.00 (6.350)

S/ R/ A/ O	Item OPT70 or MOD70	Required (R) or Standard (S) or Optional (A or O) equipment	Weight per unit lb (kg)	Arm in. (m)
22 - Auto flight				
S	0305-22	Upgrading of AFCS GFC 700 composed of : - Pitch servo GSA 81 + Servo mount GSM 86 - Roll servo GSA 81 + Servo mount GSM 86 - Yaw servo GSA 81 + Servo mount GSM 86 - Pitch trim servo GSA 81+ Servo mount GSM 86 - Trim adapter GTA 82 - AFCS Control Unit GMC 710		
			4.08 (1.85)	247.40 (6.284)
			4.08 (1.85)	231.10 (5.870)
			4.08 (1.85)	253.70 (6.444)
			4.14 (1.88)	157.87 (4.010)
			1.30 (0.59)	240.87 (6.118)
			0.91 (0.41)	156.61 (3.978)

S/ R/ A/ O	Item OPT70 or MOD70	Required (R) or Standard (S) or Optional (A or O) equipment	Weight per unit lb (kg)	Arm in. (m)
23 - Communications				
O	0633-34A	Antenna CI105-16	0.397 (0.180)	237.32 (6.028) or 155.94 (3.961) or 161.33 (4.098)
S		Static dischargers DSC 740049 (Qty : 2)	Neglig.	/
S		Static dischargers 2-5 SCY (Qty : 2)	Neglig.	/
S		Static dischargers 2-9 SCY (Qty : 3)	Neglig.	/
S		Static dischargers 2-31 SCY (Qty : 2)	Neglig.	/
A	0526-23A	Static dischargers 2-5 SCY (Qty : 2) on flaps	Neglig.	/
S	0526-23A	Static dischargers 2-5 SCY (Qty : 2) on flaps	Neglig.	/
O	0287-23A	Radio stereo-headset A20 with bluetooth	Neglig.	/
O	0487-23A	Radio stereo-headset A20	Neglig.	/
O	0331-23	Weather Data Link and Satellite Phone GSR 56 Post-MOD70-0476-00 Version B with GDU SW 6.51 - Version J : with antenna CI 490-490 (GSR unit support pre-installed)	3.44 (1.561)	58.00 (1.474)

S/ R/ A/ O	Item OPT70 or MOD70	Required (R) or Standard (S) or Optional (A or O) equipment	Weight per unit lb (kg)	Arm in. (m)
A	0410-23B	HF Communication System KHF1050 of which	38.03 (17.250)	302.70 (7.689)
		- Control Display unit	1.56 (0.707)	155.43 (3.948)
		- Receiver/Exciter	5.90 (2.676)	123.07 (3.126)
		- Antenna coupler	16.20 (7.348)	342.28 (8.694)
		- Power amplifier	8.40 (3.810)	342.83 (8.708)
		- HF Antenna kit	1.74 (0.790)	324.80 (8.250)
A	0458-23B	GDL 69A SXM - XM Generation 4 interfaced with G3000 system	1.41 (0.640)	163.46 (4.152)
S	0476-00A	G3000 COM # 1 system		
		- Transceiver (integrated in GIA 63W Integrated Avionics Unit # 1 - refer to ATA 34-28)		
		- VHF antenna (under fuselage) 16-21B-P3	0.86 (0.390)	271.65 (6.900)
S	0476-00A	G3000 COM # 2 system		
		- Transceiver (integrated in GIA 63W Integrated Avionics Unit # 2 - refer to ATA 34-28)		
		- VHF antenna (above fuselage) 16-21B-P3	0.86 (0.390)	271.65 (6.900)
S	0563-23A	Dual audio system with integrated Marker Beacon Receiver # 1 GMA 36B	2.80 (1.27)	148.90 (3.782)

Pilot's Operating Handbook

S/ R/ A/ O	Item OPT70 or MOD70	Required (R) or Standard (S) or Optional (A or O) equipment	Weight per unit lb (kg)	Arm in. (m)
S	0563-23A	Dual audio system with integrated Marker Beacon Receiver # 2 GMA 36B	2.80 (1.27)	148.90 (3.782)
S	0564-31A	G3000 COM # 1 system - Transceiver (integrated in GIA 64W Integrated Avionics Unit # 1 - refer to ATA 34-28) - VHF antenna (under fuselage) 16-21B-P3	0.86 (0.390)	271.65 (6.900)
S	0564-31A	G3000 COM # 2 system - Transceiver (integrated in GIA 64W Integrated Avionics Unit # 2 - refer to ATA 34-28) - VHF antenna (above fuselage) 16-21B-P3	0.86 (0.390)	271.65 (6.900)

S/ R/ A/ O	Item OPT70 or MOD70	Required (R) or Standard (S) or Optional (A or O) equipment	Weight per unit lb (kg)	Arm in. (m)
		24 - Electrical power		
		24-30 - DC generation		
R	0234-24	Electric power system (EPS) 1408-1-1	14.330 (6.500)	128.15 (3.255)
R		Stand-by alternator ES10024B-5	13.000 (5.897)	104.84 (2.663)
R		Starter generator MG94K-1	31.989 (14.510)	118.83 (2.815)
S	24002A	Lead-acid battery RG-380E/44	85.979 (39.000)	112.20 (2.850)
A	0303-24	Charger/Maintainer for lead acid battery	0.220 (0.100)	114.17 (2.900)
A	0538-24A	Capability to connect a battery charger	0.396 (0.180)	137.00 (3.495)
		24-40 - External power supply		
S		Ground power receptacle MS 3506-1	0.794 (0.360)	114.17 (2.900)

S/ R/ A/ O	Item OPT70 or MOD70	Required (R) or Standard (S) or Optional (A or O) equipment	Weight per unit lb (kg)	Arm in. (m)
25 - Equipment and furnishings				
25-11 - Furnishing - Flight compartment				
A	25032	Front seats ease covers	2.756 (1.250)	183.78 (4.668)
A	0417-25	Support device for document on yoke (one on each control wheel)	/	/
		- Version A : paper clips	Neglig.	166.00 (4.220)
		- Version B : mechanical provision for mounting device dedicated to digital tablet	1.984 (0.900)	166.00 (4.220)
25-21 - Furnishing - Passengers compartment				
A	0386-25	Leather upholstery "Vulcain"	6.614 (3.000)	212.60 (5.400)
S	0557-25B	Coat hanger	0.28 (0.130)	287.90 (7.313)
A	0304-25	Cabin fitting out ("Autolux" leather upholstery variants)		
		- Version C : Sateen Chocolate-coloured seats and cabinets	/	/
		- Version D : Carbon-coloured Finishing	/	/
		- Version E : Grey-coloured seats and cabinets	/	/

S/ R/ A/ O	Item OPT70 or MOD70	Required (R) or Standard (S) or Optional (A or O) equipment	Weight per unit lb (kg)	Arm in. (m)
S	0374-25B	Servicing plugs unit, of which : - 12 VDC servicing plugs unit (Qty : 2 - one in the cockpit, one in the cabin), of which : . 28-12 VDC Converter AK-551-18S - 5 VDC servicing plugs unit (USB type) (Qty : 4 - two in the cockpit, two in the cabin) with integrated charger	3.75 (1.700) 3.31 (1.500) 2.98 (1.350) 0.44 (0.200)	/ 195.28 (4.960) 195.28 (4.960) 187.99 (4.775)
S	0374-25C	Additional servicing plugs unit - 5 VDC servicing plugs unit (USB type) (Qty : 1 - on L.H. intermediate seat) with integrated charger	/ 0.20 (0.100)	/ 219.29 (5.570)
O	0374-25C	Additional servicing plugs unit - 5 VDC servicing plugs unit (USB type) (Qty : 1 - on L.H. intermediate seat) with integrated charger	/ 0.20 (0.100)	/ 219.29 (5.570)
O	0374-25D	Servicing plugs unit, of which : - 12 VDC servicing plugs unit (Qty : 2 - one in the cockpit, one in the cabin), of which : . 28-12 VDC Converter 6430120-1 - 5 VDC servicing plugs unit (USB type) (Qty : 4 - two in the cockpit, two in the cabin) 6430102-1	3.31 (0.800) 0.60 (0.270) 0.44 (0.200)	195.28 (4.960) 195.28 (4.960) 187.99 (4.775)
O	0515-25	One piece cabin floor protection	Δ0	/

S/ R/ A/ O	Item OPT70 or MOD70	Required (R) or Standard (S) or Optional (A or O) equipment	Weight per unit lb (kg)	Arm in. (m)
S	0530-25A	Hi-power USB servicing plugs, of which : - one 5 VDC servicing single plug (USB type) 6430202-9 - on instrument panel, pilot side - one 5 VDC servicing double plug unit (USB type) 6430202-5 - on instrument panel, front R.H.seat side - two 5 VDC servicing double plug units (USB type) 6430202-5 - in the cabin (R.H. and L.H. Intermediate seats)	0.33 (0.15) / / / /	188.00 (4.775) / / /
S	0531-25A	13.8 VDC servicing plug unit, of which : - 28-12 VDC Converter - 13.8 VDC servicing plug	0.74 (0.334) 0.60 (0.270) 0.14 (0.064)	193.00 (4.900) 193.00 (4.900) 288.00 (7.310)
O	0574-25B	Pilot door thermal insulation	0.55 (0.250)	172.05 (4.370)
S	0574-25B	Pilot door thermal insulation	0.55 (0.250)	172.05 (4.370)
Seats - Belts				
Belts				
O	0388-25A	Airbag seat belts (pilot's and R.H. front seats)	15.08 (6.840)	189.11 (4.803)
O	0388-25B	Airbag seat belts (pilot's and R.H. front seats) (improved comfort)	15.08 (6.840)	189.11 (4.803)
S	0516-25A	Pilot's and passengers' seat belts	10.24 (4.640)	/

S/ R/ A/ O	Item OPT70 or MOD70	Required (R) or Standard (S) or Optional (A or O) equipment	Weight per unit lb (kg)	Arm in. (m)
S	0568-25A	Airbag capability	1.43 (0.647)	166.85 (4.238)
		Seats		
S		Pilot's seat T700C2500002	55.12 (25.00)	183.90 (4.671)
S	0553-25A	Pilot's seat T700J2500005 (From S/N 1160)	48.90 (22.20)	185.86 (4.721)
S	0588-25A	Pilot's seat T700J2500005 with seat heaters system (From S/N 1215)	49.98 (22.67)	185.86 (4.721)
S		Front R.H. seat T700C2500002	55.12 (25.00)	183.90 (4.671)
S	0553-25A	Front R.H. seat T700J2500005 (From S/N 1160)	48.90 (22.20)	185.86 (4.721)
S	0588-25A	Front R.H. seat T700J2500005 with seat heaters system (From S/N 1215)	49.98 (22.67)	185.86 (4.721)
		25-60 - Emergency equipment		
S		Smoke goggles MXP 210	0.855 (0.388)	200.00 (5.080)
		25-61 - Emergency locator transmitter		
A	0437-25B	Emergency locator transmitter ELT 1000 (airplanes equipped with reinforcement), of which	2.385 (1.082)	340.91 (8.659)
		- ELT 1000 with base	1.764 (0.800)	354.72 (9.010)
		- Antenna 110-338	0.449 (0.204)	318.70 (8.095)

S/ R/ A/ O	Item OPT70 or MOD70	Required (R) or Standard (S) or Optional (A or O) equipment	Weight per unit lb (kg)	Arm in. (m)
26 - Fire protection				
A	0391-26	Portable fire extinguisher unit 74-00 - Version A (on R.H. Station R.H. Upholstering)	4.89 (2.220)	170.11 (4.321)
A	0496-26A	Engine fire detection system	1.464 (0.664)	96.06 (2.440)

S/ R/ A/ O	Item OPT70 or MOD70	Required (R) or Standard (S) or Optional (A or O) equipment	Weight per unit lb (kg)	Arm in. (m)
27 - Flight controls				
27-10 - Roll control				
R		Roll trim actuator 145700.02 (equipped assy T7002710018)	1.543 (0.700)	212.60 (5.400)
27-20 - Yaw control				
R		Rudder trim actuator 145700.02 (equipped assy T7002720018)	1.543 (0.700)	395.27 (10.040)
S	0348-27	New control wheels		
S		- L.H. equipped control wheel 83912112	2.535 (1.150)	157.48 (4.000)
S		- R.H. equipped control wheel 83912113	2.535 (1.150)	157.48 (4.000)
27-30 - Pitch control				
S		Pitch trim actuator 145400-02	1.213 (0.550)	425.20 (10.800)
S	0510-27A	Stick shaker C-101702-1	1.053 (0.477)	144.00 (3.658)
A	0510-27B	Stick shaker C-101702-1	1.053 (0.477)	144.00 (3.658)
S	0510-27D	Stick shaker C-101702-1	1.053 (0.477)	144.00 (3.658)

S/ R/ A/ O	Item OPT70 or MOD70	Required (R) or Standard (S) or Optional (A or O) equipment	Weight per unit lb (kg)	Arm in. (m)
		27-50 - Wing flaps (control)		
R		Flap control including :	15.520 (7.040)	218.50 (5.550)
		- Flap motor 6157-1	2.866 (1.300)	216.54 (5.500)
		- Flap actuator 1-5297 / 2-5297	1.830 (0.830)	220.47 (5.600)

S/ R/ A/ O	Item OPT70 or MOD70	Required (R) or Standard (S) or Optional (A or O) equipment	Weight per unit lb (kg)	Arm in. (m)
		28 - Fuel system		
		28-20 - Fuel supply		
R		Electric boost pump 1B9-5	4.409 (2.000)	129.92 (3.300)
R		Engine driven fuel pump 1127-02	1.543 (0.700)	110.24 (2.800)
R		Fuel unit L88A15-651	4.586 (2.080)	133.07 (3.380)
R		A35 fuel sequencer unit	1.102 (0.500)	125.98 (3.200)
		28-40 - Fuel indication		
R	0158-28C	Fuel gage amplifier (in us gal) 738574-1-0	1.08 (0.49)	278.74 (7.080)
R		Inboard L.H. Gage 762 438.1.0	0.331 (0.150)	183.07 (4.650)
R		Inboard R.H. Gage 762 439.1.0	0.331 (0.150)	183.07 (4.650)
R		Intermediate gage 762 440.1.0	0.220 (0.100)	190.94 (4.850)
R		Outboard gage 762 441.1.0	0.220 (0.100)	190.94 (4.850)
R	0427-28A	Low level sensor 747-971-1-0	0.143 (0.065)	185.28 (4.706)

S/ R/ A/ O	Item OPT70 or MOD70	Required (R) or Standard (S) or Optional (A or O) equipment	Weight per unit lb (kg)	Arm in. (m)
30 - Ice and rain protection				
S		Deicer T700A3013003000, L.H. horizontal stabilizer	4.189 (1.900)	398.42 (10.120)
S		Deicer T700A3013003001, R.H. horizontal stabilizer	4.189 (1.900)	398.42 (10.120)
S		Deicer T700A3014003000, vertical stabilizer	3.968 (1.800)	374.02 (9.500)
S		Deicer T700A3010001002, inboard L.H. wing	5.732 (2.600)	173.23 (4.400)
S		Deicer T700A3010001003, inboard R.H. wing	5.732 (2.600)	173.23 (4.400)
S		Deicer T700A3010001004, middle L.H. wing	3.748 (1.700)	173.23 (4.400)
S		Deicer T700A3010001005, middle R.H. wing	3.748 (1.700)	173.23 (4.400)
S		Deicer T700A3010012000, outboard L.H. wing	2.65 (1.200)	173.23 (4.400)
S		Deicer T700A3010001007, outboard R.H. wing	3.307 (1.500)	173.23 (4.400)
S		Dual port distribution valve 1532-10C	2.425 (1.100)	125.98 (3.200)
S		Timer 42E25-2A	0.772 (0.350)	177.17 (4.500)
S		Water separator and filter 44E21-2A	1.102 (0.500)	125.98 (3.200)
30-40 - Windshield deicing				
S		Windshield heater controllers (Qty 2 : L.H. + R.H.) TWH 93-01	1.984 (0.900)	149.61 (3.800)

S/ R/ A/ O	Item OPT70 or MOD70	Required (R) or Standard (S) or Optional (A or O) equipment	Weight per unit lb (kg)	Arm in. (m)
S		30-60 - Propeller deicing Timer 3E2311-4	0.44 (0.200)	200.79 (5.100)

S/ R/ A/ O	Item OPT70 or MOD70	Required (R) or Standard (S) or Optional (A or O) equipment	Weight per unit lb (kg)	Arm in. (m)
31 - Indicating/recording systems				
31-20 - Independent instruments				
O	31002A	Hourmeter 56457-3 (engine running time)	0.551 (0.250)	156.30 (3.970)
S		Hourmeter 56457-3 (flying time)	0.551 (0.250)	156.30 (3.970)
31-30 - Recorders				
S	0455-31B	Light weight Flight Data Recorder (ADRS - CARS), of which :	5.659 (2.567)	256.50 (6.515)
		- Light Data Recorder	4.982 (2.260)	260.63 (6.620)
		- MK170 microphone	0.198 (0.090)	153.54 (3.900)
		- Support (pre-installed)	0.478 (0.217)	260.63 (6.620)
S	0455-31D	Light weight Flight Data Recorder (ADRS - CARS), of which :	5.659 (2.567)	256.50 (6.515)
		- Light Data Recorder	4.982 (2.260)	260.63 (6.620)
		- MK170 microphone	0.198 (0.090)	153.54 (3.900)
		- Support (pre-installed)	0.478 (0.217)	260.63 (6.620)
S	0533-31A	Digital hourmeter (flying time) - From S/N 1160	0.412 (0.187)	148.62 (3.775)
S	0564-31A	Avionics processing Unit # 1 GIA 64W	7.50 (3.40)	147.8 (3.753)

S/ R/ A/ O	Item OPT70 or MOD70	Required (R) or Standard (S) or Optional (A or O) equipment	Weight per unit lb (kg)	Arm in. (m)
S	0564-31A	Avionics processing Unit # 2 GIA 64W	7.50 (3.40)	147.8 (3.753)
A	0578-31A	Data collection and transmission system (FASTBOX)	3.62 (1.64)	125.2 (3.180)
A	0578-31B	Data collection and transmission system (FASTBOX)	3.62 (1.64)	125.2 (3.180)
A	0578-31C	Data collection and transmission system (FASTBOX)	3.62 (1.64)	125.2 (3.180)

S/ R/ A/ O	Item OPT70 or MOD70	Required (R) or Standard (S) or Optional (A or O) equipment	Weight per unit lb (kg)	Arm in. (m)
32 - Landing gears				
32-10 - Main landing gear				
R	0190-32	L.H. main landing gear D23767001	53.79 (24.400)	200.39 (5.090)
R	0190-32	R.H. main landing gear D23768001	53.79 (24.400)	200.39 (5.090)
32-20 - Nose landing gear				
R	0134-32	Nose gear D23766000	53.57 (24.300)	93.70 (2.380)
32-30 - Extension and retraction				
O	0334-32	Main locking actuator VSTS 083560	13.228 (6.000)	208.07 (5.285)
O	0334-32	Nose locking actuator VSTS 083560	13.228 (6.000)	110.24 (2.800)
R		Hand pump 914-8D27	2.326 (1.055)	181.10 (4.600)
32-35 - Hydraulic generation				
R	060-32	Hydraulic power pack 1118-04	10.362 (4.700)	84.65 (2.150)

S/ R/ A/ O	Item OPT70 or MOD70	Required (R) or Standard (S) or Optional (A or O) equipment	Weight per unit lb (kg)	Arm in. (m)	
32-40 - Wheels and brakes					
R		Brake assembly 030-19100	14.991 (6.800)	204.33 (5.190)	
O	0606-32	Brake assembly 30-311	14.991 (6.800)	204.33 (5.190)	
R		Main tire 18x5.5-10PR	13.50 (6.123)	204.33 (5.190)	
R	0409-32	Main tire 18x5.5-10PR	14.396 (6.530)	204.33 (5.190)	
R		Master cylinder 010-07802	0.882 (0.400)	145.67 (3.700)	
O	0643-32	Nose tire 070-310-0	5.709 (2.590)	98.18 (2.494)	
R		Nose tire 5.00-5-10PR TL			
			MICHELIN	5.600 (2.540)	89.57 (2.275)
			GOOD YEAR	6.300 (2.858)	89.57 (2.275)
R	0408-32	Nose tire 5.00-5-10PR	6.834 (3.100)	89.57 (2.275)	
R		Nose wheel 40-262A	2.976 (1.350)	89.57 (2.275)	
O		Main wheel (Model 40-434)	11.28 (5.120)	204.33 (5.190)	
O	0606-32	Main wheel (Model 40-489)	11.28 (5.120)	204.33 (5.190)	
R		Parking brake valve T700A3240010 or T700B3240001	0.331 (0.150)	157.48 (4.000)	

S/ R/ A/ O	Item OPT70 or MOD70	Required (R) or Standard (S) or Optional (A or O) equipment	Weight per unit lb (kg)	Arm in. (m)
33 - Lights				
33-10 - Instrument panel lighting				
S		Instruments emergency lighting 2240-3	0.110 (0.050)	181.10 (4.600)
S	0322-00	PULSELITE unit	Neglig.	/
33-40 - External lighting				
S		L.H. wing inspection light (icing detection) T700G3340020	0.20 (0.090)	151.57 (3.850)
S	0509-33	Leading edge ice detection LED light 01-0771904-00	0.25 (0.113)	172.00 (4.371)
S	0322-00	LED L.H. taxi and landing lights 01-0771674-01	1.400 (0.635)	181.10 (4.600)
S	0322-00	LED R.H. taxi and landing lights 01-0771674-01	1.400 (0.635)	181.10 (4.600)
S	0322-00	NAV/Anticollision system (LED lights) :		
S		Central units :		
S		- L.H. strobe light power supply 01-0771234-07	0.609 (0.277)	191.38 (4.861)
S		- R.H. strobe light power supply 01-0771234-07	0.609 (0.277)	191.38 (4.861)
S		- Rear strobe light power supply	0.609 (0.277)	397.87 (10.106)

S/ R/ A/ O	Item OPT70 or MOD70	Required (R) or Standard (S) or Optional (A or O) equipment	Weight per unit lb (kg)	Arm in. (m)
S		Lights :		
S		- L.H. navigation/strobe/recognition lights 01-0771170-02	0.499 (0.227)	184.29 (4.681)
S		- R.H. navigation/strobe/recognition lights 01-0771170-01	0.499 (0.227)	184.29 (4.681)
S		- Rear tail navigation/strobe lights 01-0790667-00	0.499 (0.227)	444.21 (11.283)

S/ R/ A/ O	Item OPT70 or MOD70	Required (R) or Standard (S) or Optional (A or O) equipment	Weight per unit lb (kg)	Arm in. (m)
34 - Navigation				
34-11 - Air data systems				
S		Pitot L heated probe AN 5812-1	0.750 (0.340)	200.79 (5.100)
S		Pitot R heated probe AN 5812-1	0.750 (0.340)	200.79 (5.100)
R		Static reference plug T700A3415017	Neglig.	/
S		Static reference selector TB30 77010000	0.220 (0.100)	157.48 (4.000)
S	0160-34A	Authorization to operate in RVSM area	/	/
S	0423-34A	Lift transducer and AoA computer installation, of which :	1.66 (0.752)	242.01 (6.147)
R		- Lift transducer P/N C-101-707-1 or P/N C-101-707-2	0.50 (0.226)	173.23 (4.400)
S		- AoA computer P/N C-101-706-1	0.74 (0.336)	273.62 (6.950)
S		- K59 and K590 relays	0.25 (0.115)	265.55 (6.745)
S	0462-34	Standby Attitude Module MD302	1.61 (0.730)	154.53 (3.925)
S	0476-00A	Air Data Computer # 1 GDC 74B	1.83 (0.83)	148.11 (3.762)
S	0476-00A	Air Data Computer # 2 GDC 74B	1.83 (0.83)	148.11 (3.762)
S	0544-34B	Air Data Computer # 1 GDC 72B	1.83 (0.83)	148.11 (3.762)

S/ R/ A/ O	Item OPT70 or MOD70	Required (R) or Standard (S) or Optional (A or O) equipment	Weight per unit lb (kg)	Arm in. (m)
S	0544-34B	Air Data Computer # 2 GDC 72B 34-21 - Heading reference system	1.83 (0.83)	148.11 (3.762)
S	0476-00A	Attitude and Heading Reference System # 1 GRS 77	3.46 (1.57)	171.77 (4.363)
S	0476-00A	Attitude and Heading Reference System # 2 GRS 77	3.46 (1.57)	171.77 (4.363)
S	0476-00A	Magnetometer # 1 GMU 44	0.48 (0.22)	180.98 (4.597)
S	0476-00A	Magnetometer # 2 GMU 44	0.48 (0.22)	180.98 (4.597)
S	0543-34B	Attitude and Heading Reference System # 1 GRS 79	3.20 (1.45)	171.77 (4.363)
S	0543-34B	Attitude and Heading Reference System # 2 GRS 79 34-23 - Magnetic compass	3.20 (1.45)	171.77 (4.363)
R		Stand-by compass C2350 L4.M23 34-28 - Electronic flight instrumentation system	0.551 (0.250)	163.39 (4.150)
A	0226-00C	Synthetic Vision System	/	/

S/ R/ A/ O	Item OPT70 or MOD70	Required (R) or Standard (S) or Optional (A or O) equipment	Weight per unit lb (kg)	Arm in. (m)
S	0476-00A	Integrated Flight Deck System G3000 composed of :		
		. PFD1 GDU 1200W	8.29 (3.76)	154.88 (3.934)
		. PFD2 GDU 1200W	8.29 (3.76)	154.88 (3.934)
		. MFD GDU 1200W	8.29 (3.76)	154.88 (3.934)
		. Engine/Airframe Interface Unit # 1 GEA 71	2.58 (1.17)	148.27 (3.766)
		. Engine/Airframe Interface Unit # 2 GEA 71	2.58 (1.17)	148.27 (3.766)
		. Integrated Avionics Unit # 1 GIA 63W	7.19 (3.26)	147.87 (3.756)
		. Integrated Avionics Unit # 2 GIA 63W	7.19 (3.26)	147.87 (3.756)
		. Touch Controller Unit # 1 GTC 580	3.99 (1.81)	156.69 (3.980)
		. Touch Controller Unit # 2 GTC 580	3.99 (1.81)	156.69 (3.980)
		. Audio box GMA 36	3.00 (1.36)	149.02 (3.785)

S/ R/ A/ O	Item OPT70 or MOD70	Required (R) or Standard (S) or Optional (A or O) equipment	Weight per unit lb (kg)	Arm in. (m)
S	0549-00A	Integrated Flight Deck System G3000 composed of :		
		- PFD1 GDU 1250W	5.49 (2.49)	154.88 (3.934)
		- PFD2 GDU 1250W	5.49 (2.49)	154.88 (3.934)
		- MFD GDU 1250W	5.49 (2.49)	154.88 (3.934)
	0565-77A	- Engine/Airframe Interface Unit # 1 GEA 71B	2.65 (1.20)	148.30 (3.766)
	0565-77A	- Engine/Airframe Interface Unit # 2 GEA 71B	2.65 (1.20)	148.30 (3.766)
	0564-31A	- Integrated Avionics Unit # 1 GIA 64W	7.50 (3.40)	147.80 (3.753)
	0564-31A	- Integrated Avionics Unit # 2 GIA 64W	7.50 (3.40)	147.80 (3.753)
	0476-00A	- Touch Controller Unit # 1 GTC 580	3.99 (1.81)	156.69 (3.980)
	0476-00A	- Touch Controller Unit # 2 GTC 580	3.99 (1.81)	156.69 (3.980)
	0563-23A	- Audio box GMA 36B	2.80 (1.27)	148.90 (3.782)
		34-30 - Surface watch		
A	0566-34A	- Surface watch function	/	/

S/ R/ A/ O	Item OPT70 or MOD70	Required (R) or Standard (S) or Optional (A or O) equipment	Weight per unit lb (kg)	Arm in. (m)
34-31 - Marker				
S		MARKER antenna DM N27-3	0.750 (0.340)	129.92 (3.300)
O	0541-23A	MARKER antenna 6216-82-00	0.990 (0.450)	121.00 (3.065)
34-41 - Stormscope				
A	34056D	Stormscope WX 500, G3000 coupled :	4.94 (2.24)	232.28 (5.900)
		- Antenna NY163	0.84 (0.38)	311.02 (7.900)
		- Processor WX500	2.27 (1.03)	255.91 (6.500)
A	34056F	Stormscope WX 500, G3000 coupled :	4.94 (2.24)	232.28 (5.900)
		- Antenna NY163	0.84 (0.38)	311.02 (7.900)
		- Processor WX500	2.27 (1.03)	255.91 (6.500)
34-42 - Weather radar				
S	0394-34C	Weather radar GWX 70, of which :	10.35 (4.47)	169.10 (4.295)
		- SAINT-GOBAIN radome 4906-100-V2	2.82 (1.280)	169.10 (4.295)
S	0430-34A	New SAINT-GOBAIN radome 4906-100-V2	2.82 (1.280)	169.10 (4.295)
O	573-34A	Ressourcing radome	2,87 (1.300)	162.99 (4.140)

S/ R/ A/ O	Item OPT70 or MOD70	Required (R) or Standard (S) or Optional (A or O) equipment	Weight per unit lb (kg)	Arm in. (m)
34-43 - Radioaltimeter				
A	0451-34B	GRA 55 radar altimeter, of which :	4.127 (1.872)	220.47 (5.600)
		- Transceiver	3.527 (1.600)	228.82 (5.812)
		- Transmitting antenna S67-2002	0.300 (0.136)	182.09 (4.625)
		and		
		- Receiving antenna S67-2002	0.300 (0.136)	205.83 (5.228)
34-44 - Traffic advisory system				
A	0176-00F	TAWS system	/	/
A	0258-00D	TAS system GTS 820, G3000 coupled, of which :	22.53 (10.220)	177.68 (4.513)
		- Processor GTS 820	9.92 (4.500)	143.11 (3.635)
		- Power amplifier/low noise amplifier GPA 65	1.90 (0.860)	221.42 (5.624)
		- Antenna GA 58 (above fuselage)	0.79 (0.360)	230.71 (5.860)
		- Antenna GA 58 (under fuselage)	0.79 (0.360)	260.63 (6.620)

S/ R/ A/ O	Item OPT70 or MOD70	Required (R) or Standard (S) or Optional (A or O) equipment	Weight per unit lb (kg)	Arm in. (m)
A	0258-00G	TAS system GTS 820, G3000 coupled, of which: - Processor GTS 820 - Power amplifier/low noise amplifier GPA 65 - Antenna GA 58 (above fuselage) - Antenna GA 58 (under fuselage)	22.53 (10.220) 9.92 (4.500) 1.90 (0.860) 0.79 (0.360) 0.79 (0.360)	177.68 (4.513) 143.11 (3.635) 221.42 (5.624) 230.71 (5.860) 260.63 (6.620)
		34-51 - NAV 1 installation		
S		VHF GS-NAV antenna DM N4-17N	3.307 (1.500)	401.57 (10.200)
S		Receiver (integrated in the MOD70-0476-00A GIA 63W Integrated Avionics Unit # 1 : refer to ATA 34-28)	/	/
S		Receiver (integrated in the MOD70-0564-31A GIA 64W Integrated Avionics Unit # 1 : refer to ATA 34-28)	/	/
		34-52 - NAV 2 installation		
S		Receiver (integrated in the MOD70-0476-00A GIA 63W Integrated Avionics Unit # 2 : refer to ATA 34-28)	/	/
S		Receiver (integrated in the MOD70-0564-31A GIA 64W Integrated Avionics Unit # 2 : refer to ATA 34-28)	/	/

S/ R/ A/ O	Item OPT70 or MOD70	Required (R) or Standard (S) or Optional (A or O) equipment	Weight per unit lb (kg)	Arm in. (m)
34-53 - Transponder				
A	0475-34A	Transponder # 1 GTX 33D - Mode S with antenna diversity and extended squitter + Antenna KA 61 (under fuselage) + Antenna KA 61 (above fuselage)	3.39 (1.54) 0.40 (0.18) 0.40 (0.18)	147.68 (3.751) 150.08 (3.812) 193.22 (4.908)
S	0475-34B	Transponder # 1 GTX 33 - Mode S without antenna diversity and with extended squitter + Antenna KA 61	3.11 (1.41) 0.40 (0.18)	147.68 (3.751) 193.22 (4.908)
A	0475-34C	Transponder # 2 GTX 33 - Mode S with antenna diversity and extended squitter + Antenna KA 61 (under fuselage) + Antenna KA 61 (above fuselage)	3.11 (1.41) 0.40 (0.18) 0.40 (0.18)	147.68 (3.751) 193.22 (4.908) 193.22 (4.908)
S	0542-34A	Transponder # 1 GTX 345R - full Mode S enhanced surveillance capability, without antenna diversity, with extended squitter and ADS-B IN acquisition (with ethernet connection) + Antenna KA 61	2.90 (1.32) 0.40 (0.18)	147.20 (3.738) 150.08 (3.812)
O	0542-34B	Transponder # 2 GTX 345R - full Mode S enhanced surveillance capability, without antenna diversity, with extended squitter and ADS-B IN acquisition (without ethernet connection) + Antenna KA 61	2.90 (1.32) 0.40 (0.18)	147.20 (3.738) 150.08 (3.812)

S/ R/ A/ O	Item OPT70 or MOD70	Required (R) or Standard (S) or Optional (A or O) equipment	Weight per unit lb (kg)	Arm in. (m)
O	0542-34C	Transponder # 2 GTX 345R - full Mode S enhanced surveillance capability, without antenna diversity, with extended squitter and ADS-B IN acquisition (with ethernet connection)	2.90 (1.32)	147.20 (3.738)
		+ Antenna KA 61	0.40 (0.18)	150.08 (3.812)
O	0542-34M	Transponder # 2 GTX 345R - full Mode S enhanced surveillance capability, without antenna diversity, with extended squitter and ADS-B IN acquisition (with ethernet connection)	2.90 (1.32)	147.20 (3.738)
		+ Antenna KA 61	0.40 (0.18)	150.08 (3.812)
O	0542-34N	Transponder # 1 GTX 345R - full Mode S enhanced surveillance capability, without antenna diversity, with extended squitter and ADS-B IN acquisition (with ethernet connection)	2.90 (1.32)	147.20 (3.738)
		+ Antenna KA 61	0.40 (0.18)	150.08 (3.812)
O	0542-34O	Transponder # 2 GTX 345R - full Mode S enhanced surveillance capability, without antenna diversity, with extended squitter and ADS-B IN acquisition (without ethernet connection)	2.90 (1.32)	147.20 (3.738)
		+ Antenna KA 61	0.40 (0.18)	150.08 (3.812)

S/ R/ A/ O	Item OPT70 or MOD70	Required (R) or Standard (S) or Optional (A or O) equipment	Weight per unit lb (kg)	Arm in. (m)
		34-54 - Automatic Direction Finder (ADF)		
A	0507-34A	ADF RA 3500 system (European countries only), of which :	7.61 (3.45)	216.48 (5.498)
		- Receiver RA3502 P/N 0505.757-912	2.205 (1.000)	259.84 (6.000)
		- Antenna AN3500 P/N 0832.601-912	3.754 (1.700)	171.85 (4.365)
		- RMI converter AC3504 P/N 0856.010-912	1.653 (0.750)	259.84 (6.000)
		34-55 - DME installation		
A	34014G	DME KN63, G3000 coupled	2.80 (1.27)	232.28 (5.900)
		+ Antenna KA 61	0.40 (0.18)	238.82 (6.066)
		34-57 - Global Positioning System (GPS)		
S	0476-00A	GPS/WAAS Antenna GA 36	0.48 (0.22)	204.84 (5.203)
S	0476-00A	GPS/WAAS and Datalink Antenna GA 37	0.55 (0.25)	204.84 (5.203)
		34-62 - Multifunction display		
A	0176-00G	Chartview function	Neglig.	/

S/ R/ A/ O	Item OPT70 or MOD70	Required (R) or Standard (S) or Optional (A or O) equipment	Weight per unit lb (kg)	Arm in. (m)
35 - Oxygen				
O	0597-35A	MC10 Smartmike oxygen mask (pilot and front passenger)	1.290 (0.585)	188.98 (4.800)
S	0207-00	Gaseous oxygen system with oxygen masks	22.73 (10.310)	226.77 (5.760)

S/ R/ A/ O	Item OPT70 or MOD70	Required (R) or Standard (S) or Optional (A or O) equipment	Weight per unit lb (kg)	Arm in. (m)
37 - Vacuum				
S		Air ejector valve 19E17-5A	0.661 (0.300)	116.14 (2.950)
S		Regulator and relief valve 38E-96-2D	1.323 (0.600)	116.14 (2.950)
S		Vacuum relief valve 691-21A	0.331 (0.150)	139.76 (3.550)
S		Valve 557-18 E	0.353 (0.160)	118.11 (3.000)

S/ R/ A/ O	Item OPT70 or MOD70	Required (R) or Standard (S) or Optional (A or O) equipment	Weight per unit lb (kg)	Arm in. (m)
46 - Information systems				
A	0459-46C	Flight stream transceiver FS210	0.264 (0.120)	151.18 (3.840)
A	0459-46D	Flight stream transceiver FS210	0.264 (0.120)	151.18 (3.840)
S	0545-46A	Pdf viewer installation (SD card)	Neglig.	/
S	0547-46C	Flight stream transceiver FS510 (SD card)	Neglig.	/

S/ R/ A/ O	Item OPT70 or MOD70	Required (R) or Standard (S) or Optional (A or O) equipment	Weight per unit lb (kg)	Arm in. (m)
52 - Doors				
S	0320-52B	New "Pilot" door	45.607 (20.687)	173.23 (4.400)
S	0342-52	Additional landing gear doors	6.613 (3.000)	204.33 (5.190)

S/ R/ A/ O	Item OPT70 or MOD70	Required (R) or Standard (S) or Optional (A or O) equipment	Weight per unit lb (kg)	Arm in. (m)
		56 - Windows		
S	56001A	Deiced R.H. windshield	Δ1.764 (Δ 0.800)	158.27 (4.020)

S/ R/ A/ O	Item OPT70 or MOD70	Required (R) or Standard (S) or Optional (A or O) equipment	Weight per unit lb (kg)	Arm in. (m)
		57 - Wings		
S	57001A	Utilization on runways covered with melting snow	Δ- 7.716 (Δ- 3.500)	200.00 (5.080)

S/ R/ A/ O	Item OPT70 or MOD70	Required (R) or Standard (S) or Optional (A or O) equipment	Weight per unit lb (kg)	Arm in. (m)
		61 - Propeller		
		61-10 - Propeller assembly		
S	0345-61	Propeller (5-blade) HC-E5N-3C / NC 8834 K + spinner 104552P	171.08 (77.60)	43.11 (1.095)
		61-20 - Controls		
S		Propeller governor 8210.007	2.646 (1.200)	59.06 (1.500)
R	0445-72	Overspeed governor 1439292	2.535 (1.200)	52.38 (1.330)

S/ R/ A/ O	Item OPT70 or MOD70	Required (R) or Standard (S) or Optional (A or O) equipment	Weight per unit lb (kg)	Arm in. (m)
		71 - Power plant		
R		Turboprop engine PT6 A-66D	497.30 (226.00)	79.72 (2.025)
S		Top silentblocks 95007-16 (Qty 2)	2.647 (1.201)	79.72 (2.025)
S		Bottom silentblocks 95007-19 (Qty 2)	2.654 (1.204)	79.72 (2.025)
		71-60 - Air inlet		
R	0359-71	Inertial separator actuator JA23372-1000-1	2.156 (0.978)	62.99 (1.600)

S/ R/ A/ O	Item OPT70 or MOD70	Required (R) or Standard (S) or Optional (A or O) equipment	Weight per unit lb (kg)	Arm in. (m)
		76 - Engine controls		
R	0558-76	Single lever power control modification for auto-throttle capability	Neglig.	/
		- Version A: Single lever power control capability	/	/
		- Version B: Non auto-throttle knob	/	/

S/ R/ A/ O	Item OPT70 or MOD70	Required (R) or Standard (S) or Optional (A or O) equipment	Weight per unit lb (kg)	Arm in. (m)
		77 - Engine indicating		
R		Compressor turbine tachogenerator (Ng) MIL-G-26611 GEU-7/A / 32005-007	0.981 (0.445)	108.27 (2.750)
R		Power turbine tachogenerator (Np) MIL-G-26611 GEU-7/A / 32005-007	0.981 (0.445)	55.12 (1.400)
R	0328-77	Torque transducer APTE-438-1000-75D	0.473 (0.215)	54.84 (1.393)
S	0565-77	Engine/Airframe Interface Units GEA 71B installation and Sandia conditioner and low pass filter removal, of which:		
		- Version A: Unit # 1 GEA 71B installation	2.65 (1.20)	148.30 (3.766)
		Unit # 2 GEA 71B installation	2.65 (1.20)	148.30 (3.766)
		- Version B Sandia conditioner and low pass filter removal	- 0.76 (- 0.34)	148.30 (3.768)
		- Version C Sandia conditioner and low pass filter removal	- 0.76 (- 0.34)	148.30 (3.768)
		77-12 - Fuel management		
S		Fuel flow transmitter 660 526AS	0.683 (0.310)	110.20 (2.799)

S/ R/ A/ O	Item OPT70 or MOD70	Required (R) or Standard (S) or Optional (A or O) equipment	Weight per unit lb (kg)	Arm in. (m)
		79 - Lubrication		
		79-20 - Distribution		
R		Oil cooler L8538233	10.472 (4.750)	90.55 (2.300)
		79-30 - Indicating		
R	0327-79A	Oil pressure transmitter APT-369A-1000-150G (5 VDC)	0.337 (0.153)	105.35 (2.676)
S	0512-79	Chip detector monitoring	Neglig.	/

Intentionally left blank

Pilot's Operating Handbook

List of supplements and validities

Sup. No.	Edit. No.	Description	Airplane type *							
			900 E0	900 E1	910 E0	910 E1	930 E0	930 E1	940 E0	
A	5	List of supplements From S/N 1000, plus S/N 687	X	X	X	X	X	X	X	
06	3	WX-500 stormscope OPT70-34-056 From S/N 1000, plus S/N 687	X	X	X	X	X	X	X	
18	3	Engine fire detection system OPT70-26-002G OPT70-26-002H MOD70-0496-26A From S/N 1000, plus S/N 687	X	X	X	X	X	X	X	
45	2	Mexico specifics MOD70-0212-11 From S/N 1000 up to S/N 1269, plus S/N 687	X	X	X	X	X	X	X	
45	3	Mexico specifics MOD70-0619-11 Version C From S/N 1270				X			X	
47	1	GARMIN GWX70 color weather radar MOD70-0394-34 From S/N 1000 to S/N 1049, plus S/N 687	X							
49	2	GARMIN TAWS System MOD70-0176-00 Version F From S/N 1000, plus S/N 687	X	X	X	X	X	X	X	
50	2	GARMIN Synthetic Vision System MOD70-0226-00 From S/N 1000, plus S/N 687	X	X	X	X	X	X	X	
* 900 E0 : From S/N 1000 to S/N 1049, plus S/N 687										
900 E1 : From S/N 1050										
910 E0 : From S/N 1170 to 1269										
910 E1 : Airplane equipped with MOD70-0539-00 Version H										
930 E0 : Airplane equipped with MOD70-476-00										
930 E1 : Airplane equipped with MOD70-549-00										
940 E0 : Airplane equipped with MOD70-0649-00 Version A										

Sup. No.	Edit. No.	Description	Airplane type *						
			900 E0	900 E1	910 E0	910 E1	930 E0	930 E1	940 E0
56	3	GARMIN GSR56 weather datalink and satellite phone MOD70-0331-23 From S/N 1000, plus S/N 687	X	X	X	X	X	X	X
57	1	Public transportation for French-registered airplanes MOD70-0352-11 From S/N 1000, plus S/N 687 with MOD70-0176-00	X	X					
58	0	Five-bladed propeller MOD70-0345-61 From S/N 1000 up to S/N 1049, plus S/N 687	X						
59	1	Brazil specifics OPT70-01004 From S/N 1000 up to S/N 1269, plus S/N 687	X	X	X		X	X	
59	3	Brazil specifics MOD70-0619-11 Version B From S/N 1270				X			X
60	1	ADS-B OUT function MOD70-0264-34 MOD70-0542-34 From S/N 1000 up to S/N 1159, plus S/N 687 with MOD70-0176-00	X	X					
62	0	Flight envelope protection and MOD70-0423-34 MOD70-0488-27 From S/N 1000 up to S/N 1169, plus S/N 687 with MOD70-0176-00	X	X					
* 900 E0 : From S/N 1000 to S/N 1049, plus S/N 687									
900 E1 : From S/N 1050									
910 E0 : From S/N 1170 to 1269									
910 E1 : Airplane equipped with MOD70-0539-00 Version H									
930 E0 : Airplane equipped with MOD70-476-00									
930 E1 : Airplane equipped with MOD70-549-00									
940 E0 : Airplane equipped with MOD70-0649-00 Version A									

Pilot's Operating Handbook

Sup. No.	Edit. No.	Description	Airplane type *							
			900 E0	900 E1	910 E0	910 E1	930 E0	930 E1	940 E0	
63	1	Lavatory compartment MOD70-0505-25 From S/N 1000, plus S/N 687	X	X	X	X	X	X	X	
64	1	Stick Shaker MOD70-0510-27 Version C From S/N 1000 to S/N 1049, plus S/N 687	X							
66	1	GARMIN G1000 NXi retrofit MOD70-0539-00 From S/N 1000 to S/N 1169	X	X						
67	0	Data collection and transmission system (FAST BOX) MOD70-0578-31 Version A From S/N 1000, plus S/N 687	X	X	X		X			
68	0	TBM930 2018 From S/N 1216					X			
69	0	Baro-VNAV approaches MOD70-0636-34 From S/N 1000, plus S/N 687, equipped with G1000 system (MOD70-0176-00) or G1000 NXi system retrofit (MOD70-0539-00 Versions D & E)	X	X	X					
71	0	JCAB Supplement for TBM940 airplane MOD70-0619-11 Version D From S/N 1272							X	
72	0	France specifics MOD70-0619-11 Version E From S/N 1270				X			X	
<p>* 900 E0 : From S/N 1000 to S/N 1049, plus S/N 687 900 E1 : From S/N 1050 910 E0 : From S/N 1170 to 1269 910 E1 : Airplane equipped with MOD70-0539-00 Version H 930 E0 : Airplane equipped with MOD70-476-00 930 E1 : Airplane equipped with MOD70-549-00 940 E0 : Airplane equipped with MOD70-0649-00 Version A</p>										

Sup. No.	Edit. No.	Description	Airplane type *						
			900 E0	900 E1	910 E0	910 E1	930 E0	930 E1	940 E0
73	0	Extended large storage cabinet MOD70-0684-25 From S/N 1270				X			X
75	0	GDR66 COM3 VHF communication MOD70-0722-23 From S/N 1272							X
*	900 E0	: From S/N 1000 to S/N 1049, plus S/N 687							
	900 E1	: From S/N 1050							
	910 E0	: From S/N 1170 to 1269							
	910 E1	: Airplane equipped with MOD70-0539-00 Version H							
	930 E0	: Airplane equipped with MOD70-476-00							
	930 E1	: Airplane equipped with MOD70-549-00							
	940 E0	: Airplane equipped with MOD70-0649-00 Version A							

SUPPLEMENT

WX-500 stormscope

Table of contents

	Page
1 - General	9.6.2
2 - Limitations	9.6.2
3 - Emergency procedures	9.6.3
4 - Normal procedures	9.6.3
5 - Performance	9.6.3
6 - Weight and balance	9.6.4
7 - Description	9.6.4
8 - Handling, Servicing and maintenance	9.6.4

SECTION 1

General

This supplement is intended to inform the pilot about the equipment limitations, description and operations necessary for operation when the TBM airplane is equipped with the option WX-500 stormscope.

Whenever this supplement refers to the WX-500 Pilot's Guide, it states the one described in section 2.

SECTION 2

Limitations

The limitations hereafter supplement or replace those of the standard airplane described in section 2 Limitations of the basic POH when the airplane is equipped with the option WX-500 stormscope.

The WX-500 stormscope systems signal displays are not intended for the purpose of penetrating thunderstorm areas or areas of severe turbulence ; such intentional use is prohibited.

• NOTE •

Range selection determines receiver sensitivity and therefore relative range. Displayed range is based on signal strength and is not to be used for accurate determination of thunderstorm location.



▲ CAUTION ▲

The stormscope must not be used for thunderstorm penetration.



The WX-500 Pilot's guide, Series II, No. 009-11501-001 and the GARMIN Integrated flight deck pilot's guide, as applicable, at their latest revision shall be readily available to the pilot, whenever the operation of the WX-500 stormscope is predicted.

SECTION 3

Emergency procedures

Installation and operation of WX-500 stormscope do not change the basic emergency procedures of the airplane described in section 3 Emergency procedures of the basic POH.

SECTION 4

Normal procedures

Normal operating procedures of the WX-500 stormscope are outlined in the WX-500 Pilot's Guide.

SECTION 5

Performance

Installation and operation of WX-500 stormscope do not change the basic performance of the airplane described in section 5 Performance of the basic POH.

SECTION 6

Weight and balance

The weight and balance hereafter supplement or replace those of the standard airplane described in section 6 Weight and balance of the basic POH when the airplane is equipped with the option WX-500 stormscope.

S/ R/ A/ O	Item OPT70 or MOD70	Required (R) or Standard (S) or Optional (A or O) equipment	Weight per unit lb (kg)	Arm in. (m)
		34 - NAVIGATION		
A	34056	Stormscope - shared with the integrated flight deck system	4.94 (2.240)	232.28 (5.900)

SECTION 7

Description

Information hereafter supplement or replace those of the standard airplane described in section 7 Description of the basic POH when the airplane is equipped with the option WX-500 stormscope.

The WX-500 (series II) stormscope, weather mapping system provides a visual screen readout of the electrical discharges associated with thunderstorms. This information with proper interpretation, will allow the pilot to detect severe thunderstorm activity. A series of green dots or of strike points will be displayed on the screen to indicate the electrical discharge areas.

The WX-500 (series II) stormscope, weather mapping system interfaces with the integrated flight deck system.

SECTION 8

Handling, servicing and maintenance

Installation and operation of WX-500 stormscope do not change the handling, servicing and maintenance procedures of the airplane described in section 8 Handling, servicing and maintenance of the basic POH.

SUPPLEMENT

Engine fire detection system

Table of contents

	Page
1 - General	9.18.2
2 - Limitations	9.18.2
3 - Emergency procedures	9.18.3
4 - Normal procedures	9.18.5
5 - Performance	9.18.5
6 - Weight and balance	9.18.6
7 - Description	9.18.7
8 - Handling, servicing and maintenance	9.18.7

SECTION 1

General

This supplement is intended to inform the pilot about the equipment limitations, description and operations necessary for operation when the airplane is equipped with the option Engine fire detection system.

The general hereafter supplement or replace those of the standard airplane described in section 1 General of the basic POH when the airplane is equipped with the option Engine fire detection system.

The fire detection system allows engine fire monitoring and indicating.

SECTION 2

Limitations

Installation and operation of Engine fire detection system do not change the basic limitations of the airplane described in section 2 Limitations of the basic POH.

SECTION 3

Emergency procedures

The emergency procedures hereafter supplement or replace those of the standard airplane described in section 3 Emergency procedures of the basic Pilot's Operating Handbook when the airplane is equipped with the option Engine fire detection system.

Engine fire on ground

Symptoms : ITT increasing, **ITT** , **FIRE** , smoke, ...

- 1 - THROTTLE CUT OFF
>> Airplane with G1000 or G1000 NXi Flight deck (MOD70-0176-00 or MOD70-0539-00)
- 2 - BLEED switch OFF / RST
>> Airplane with G3000 Flight deck (MOD70-0476-00)
- 3 - BLEED switch OFF
>> All
- 4 - A/C switch OFF

- 5 - Brakes As required
- 6 - FUEL TANK SLECTOR OFF
- 7 - Warn ground assistance, if necessary
- 8 - Crash lever Pull down

► Evacuate as soon as possible ◀

Engine fire in flight

Symptoms : **FIRE**

Try to confirm the fire warning by looking for other indications such as ITT increase, **ITT** , smoke from engine cowls or air conditioning system.

▲ **CAUTION** ▲

No air start attempt after an engine fire.



▶ **Fly the airplane** ◀

If the fire warning is not confirmed :

- 1 - Monitor the engine parameters, ITT in particular
- 2 - Look for smoke coming from engine cowls or from air conditioning system

▶ Land as soon as possible ◀

If the fire warning is confirmed :

- | | |
|------------------------------|---------|
| 1 - THROTTLE | CUT OFF |
| 2 - AUX BP switch | OFF |
| 3 - FUEL TANK SELECTOR | OFF |
| 4 - Oxygen mask | Use |

>> *Airplane with G1000 or G1000 NXi Flight deck (MOD70-0176-00 or MOD70-0539-00)*

- 5 - BLEED switch OFF / RST

>> *Airplane with G3000 Flight deck (MOD70-0476-00)*

- 6 - BLEED switch OFF

>> *All*

- 7 - A/C switch OFF
- 8 - If necessary, Emergency descent
- 9 - Perform Forced landing

SECTION 4

Normal procedures

The normal procedures hereafter supplement or replace those of the standard airplane described in section 4 Normal procedures of the basic Pilot's Operating Handbook when the airplane is equipped with the option Engine fire detection system.

- Before starting the engine

■ >> *Up to S/N 1105, plus S/N 687, on left side of left instrument panel*

FIRE TEST push-button Press

■ >> *From S/N 1106, on upper panel*

TEST push-button Press

■ >> *All*

FIRE lights on and causes the illumination of the MASTER WARNING light.

SECTION 5

Performance

Installation and operation of Engine fire detection system do not change the basic performance of the airplane described in section 5 Performance of the basic Pilot's Operating Handbook.

SECTION 6

Weight and balance

The weight and balance hereafter supplement or replace those of the standard airplane described in section 6 Weight and balance of the basic Pilot's Operating Handbook when the airplane is equipped with the option Engine fire detection system.

S/ R/ A/ O	Item OPT70 or MOD70	Required (R) or Standard (S) or Optional (A or O) equipment	Weight per unit lb (kg)	Arm in. (m)
26 - Fire protection				
A	26002G or 26002 H	Engine fire detection system L'HOTELLIER (From S/N 1000 to 1105, plus S/N 687)	1.455 (0.660)	96.06 (2.440)
A	0496-26A	Engine fire detection system L'HOTELLIER (From S/N 1106)	1.464 (0.66)	96.06 (2.440)

SECTION 7

Description

Information hereafter supplement or replace those of the standard airplane described in section 7 Description of the basic Pilot's Operating Handbook when the airplane is equipped with the option Engine fire detection system.

The engine fire detection system enables the monitoring and indication of a fire in the engine area.

The system includes :

- 7 detectors
- the test push-button
- the integrated flight deck system.

Detectors

The 7 detectors are secured on supports positioned in the most sensitive engine areas. They consist of thermal switches detecting a temperature greater than 200°C.

Push-button

The push-button enables the pilot to test the detection system by opening the grounding circuit. It is connected in series with the 7 detectors.

>> *Up to S/N 1105, plus S/N 687*

The FIRE TEST push-button is located on left side of left instrument panel.

>> *From S/N 1106*

The TEST push-button is located on upper panel.

Display

Refer to the GARMIN Integrated Flight Deck Pilot's Guide, as applicable, at its latest revision.

SECTION 8

Handling, servicing and maintenance

Installation and operation of Engine fire detection system do not change the basic handling, servicing and maintenance procedures of the airplane described in section 8 Handling, Servicing and Maintenance of the basic Pilot's Operating Handbook.

Intentionally left blank

SUPPLEMENT

Mexico specifics

Table of contents

	Page
1 - General	9.45.2
2 - Limitations	9.45.2
Internal placards	9.45.2
External placards	9.45.10
3 - Emergency procedures	9.45.18
4 - Normal procedures	9.45.18
5 - Performance	9.45.18
6 - Weight and balance	9.45.18
7 - Description	9.45.19
8 - Handling, servicing and maintenance	9.45.19

SECTION 1

General

This supplement is intended to inform the pilot about the airplane specifics, among others those required by the relevant Certification Authorities (limitations, description and operations necessary to the operation of the TBM airplane).

SECTION 2

Limitations

The limitations hereafter supplement or replace those of the standard airplane described in section 2 Limitations of the basic POH.

2.9 - Placards

Internal placards

- 1 - Rear pressurized baggage compartment (in cabin)

On partition wall

MÁXIMO 100 kg - (220 lbs)

**ES RESPONSABILIDAD DEL PILOTO
COMPROBAR QUE TODO EL EQUIPAJE ESTÁ
ASEGURADO CORRECTAMENTE.
PARA INSTRUCCIONES DE CARGA REFIERASE A
LOS "DATOS DE PESO Y BALANCE"
DEL MANUAL DE OPERACIÓN DEL PILOTO.**

Pilot's Operating Handbook

For the small cargo net, on frame C13bis



For the large cargo net, on R.H. Side upholstery panel, in the rear baggage compartment



2 - Non pressurized FWD baggage compartment

On baggage compartment door frame

MÁXIMO 50 kg - (110 lbs)

PARA INSTRUCCIONES DE CARGA REFERASE A LOS "DATOS DE PESO Y BALANCE" DEL MANUAL DE OPERACIÓN DEL PILOTO.

- 3 - On R.H. side at front seat level and on the first rear passengers masks container (R.H. side on the ceiling)

I4112003AAAFA18101



- 4 - On rear passengers masks containers (on R.H. side on the ceiling and left side)

I4112003AAAFA18201



- 5 - On rear passenger's table casing



Pilot's Operating Handbook

- 6 - Door internal side
On access door



On pilot door, if installed



- 7 - On emergency exit handle

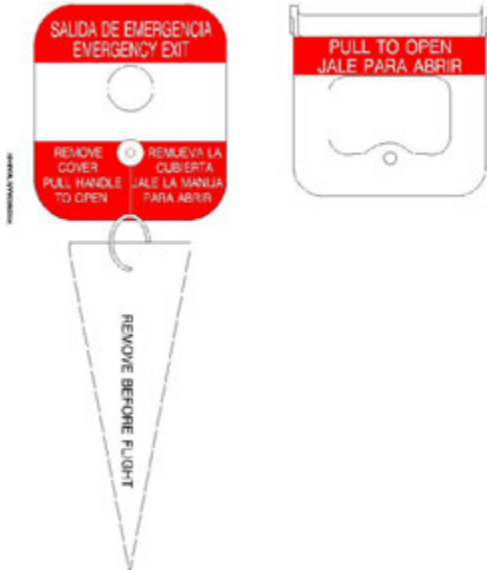

- 8 - On landing gear emergency control access door

I4112003AAAMA18400

**LDG GEAR EMERGENCY
ACCESS PULL
TREN DE ATERRIZAJE
DE EMERGENCIA
JALE AQUI**

- 9 - At the upper corner of the window on each side of the cockpit

I4112003AAAHMAB301

**HANDLE
HERE
MANIJA
AQUI**

- 10 - On cabinet drawer (optional)

I4112003AAALMA18000

GAFAS PARA HUMO

>> *Airplane equipped with coat hanger (Post-MOD70-0557-25)*

- 11 - On the upper edge of the L.H. Passenger access door panel

I4113200AAAKMA18200

SOLO PRENDAS DE VESTIR

Pilot's Operating Handbook

>> *Airplane equipped with lavatory compartment (Post-MOD70-0505-25)*

12 - On fixed panel, cabin side

I4113200AAAKMA8300

EL DIVISOR DEBE ESTAR ALMACENADO DURANTE EL DESPEGUE Y EL ATERRIZAJE

13 - On fixed panel, toilet side

I4113200AAA-KMA8000

**EL INODORO NO DEBE
ESTAR OCUPADO DURANTE EL
DEPEGUE Y EL ATERRIZAJE

CIERRE Y ASEGURE LA TAPA
DEL INODORO CUANDO NO ESTÉ EN USO
NO CUELQUE O GUARDE OBJETOS
EN EL BAÑO O DIVISOR

EL DIVISOR DEBE ESTAR ALMACENADO
DURANTE EL DESPEGUE Y EL ATERRIZAJE
USE LOS AURICULARES CUANDO EL
DIVISOR ESTÉ DESPLEGADO**

14 - On access door, cabin side and toilet side

I4113200AAAKMA8200



15 - Behind access door, cabin side and toilet side

I4113200AAAKMA8100



Pilot's Operating Handbook

16 - Front face of lavatory compartment, near opening / closing switches



I4113200AAA KMA18000

ALMACENAR

I4113200AAA KMA8400

DESPLEGAR

17 - On the magazine rack

I4113200AAA KMA18100

1,5 KG (3.3 LBS)

>> All

External placards

18 - Under engine cowling and under each wing

I4112003AAAHA1A183DC



19 - Near fuel tank caps

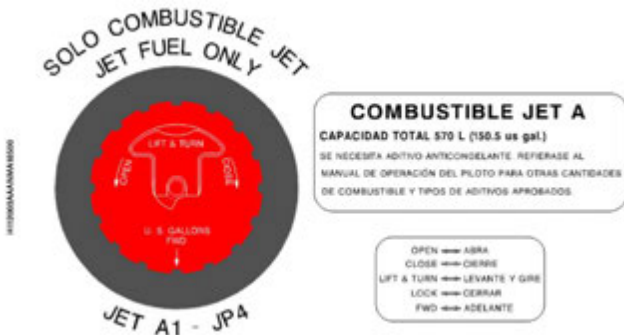

I4112003AAAHA1A183DC

I4112003AAAHA1A183DC

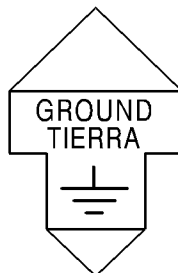

Pilot's Operating Handbook

20 - Above brakes hydraulic fluid reservoir against firewall

I4112003AAA HMA18101

FRENOS
MIL - H - 5606
AIR 3520
FLUIDO HIDRÁULICO

21 - On landing gear hydraulic fluid reservoir

I4112003AAA HMA18001

GEARS
TRENES
MIL - H - 5606
AIR 3520
HYDRAULIC FLUID
FLUIDO HIDRÁULICO

22 - On fuse box in engine cowling

I4112003AAA HMA18000

CAJA DE FUSIBLES
Y FOCOS

23 - On internal face of L.H. engine cowling

I4112003AAAEMAB300



I4112003AAA HMA8101

OILS - ACEITES	
<input type="checkbox"/>	AEROSHELL 560
<input type="checkbox"/>	EXXON 2380 OR ESSO 2380 OR BPTO 2380
<input type="checkbox"/>	MOBIL JET OIL II
<input type="checkbox"/>	MOBIL JET OIL 254
<input type="checkbox"/>	AERO SHELL TURBINE OIL 500
<input type="checkbox"/>	ROYCO TURBINE OIL 500
<input type="checkbox"/>	CASTROL 5000
<input type="checkbox"/>	TURBONYCOIL 525-2A

24 - On front lower portion of firewall L.H. side

I4112003AAA HMA8401

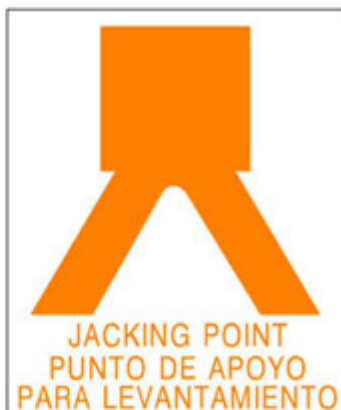

Pilot's Operating Handbook

25 - On engine cowling, in front of compartment door

I4112003AAAAGMA18500

**ALIMENTACIÓN EXTERNA:
28 VOLTS C.D. NOMINAL.
CAPACIDAD MÍNIMA DE ARRANQUE:
800 AMPS
NO EXCEDER 1000 AMPS**

26 - On nose gear door

I4112003AAAEIMA18101

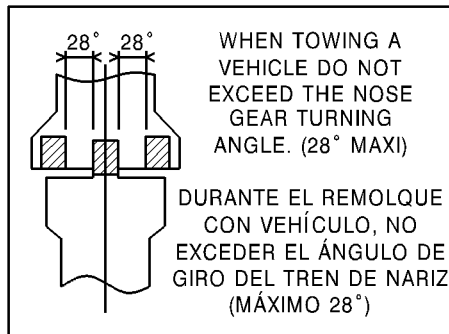

27 - On nose gear leg

I4112003AAAAIMA8200

**TREN DE ATERRIZAJE
DE NARIZ**

**PRESIÓN DE LLANTA: 6,5 bar
94 psi**

28 - On main gear leg

I4112003AAA IMA 8300

**TREN DE ATERRIZAJE
PRINCIPAL**
**PRESIÓN DE LLANTA: 8,96 bar
130 psi**

29 - On internal face of the oxygen cylinder service door

I4112003AAATMA 18301

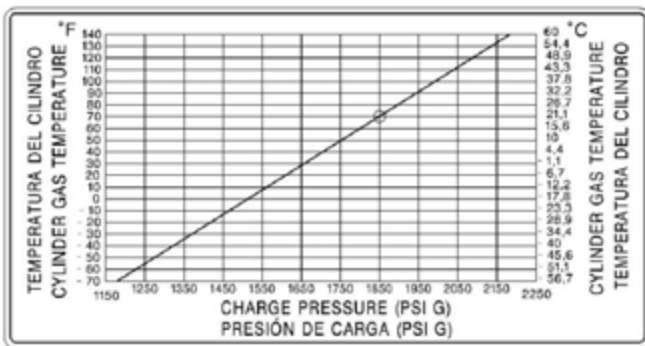

30 - On the oxygen service door

I4112003AAA IMA 18101

**PUNTO DE SERVICIO PARA
OXÍGENO. NO USAR LUBRICANTES**

Pilot's Operating Handbook

31 - Near air data system port

I4112003AAA.HMA.8001

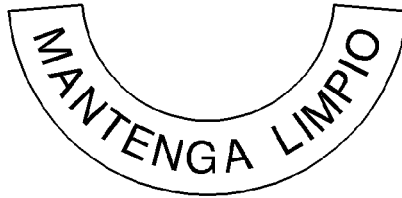

32 - On external side of emergency locator transmitter inspection door

I4112003AAA.HMA.1B400



33 - On emergency exit external side

I4112003AAA.FM.A8500



34 - Door external side

On pilot door

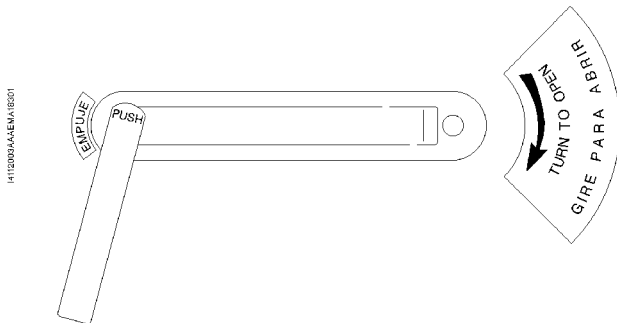

On access door

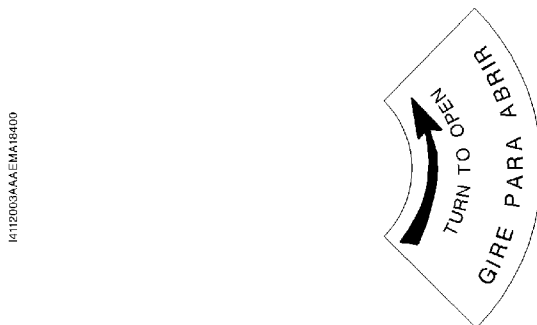

On outer fuselage skin aft of access door and in the cabin forward of access door



Pilot's Operating Handbook

35 - On last step of stairs

CARGA MÁXIMA SOBRE LA ESCALERA : UNA PERSONA

36 - On R.H. access door jamb

44112003AAK7MA18001

**NO USAR EL
PASAMANO
PARA RETRAER
O GUARDAR LA
ESCALERA**

SECTION 3
Emergency procedures

No specifics

SECTION 4
Normal procedures

No specifics

SECTION 5
Performance

No specifics

SECTION 6
Weight and balance

The weight and balance hereafter supplement or replace those of the standard airplane described in section 6 Weight and balance of the basic POH.

S/ R/ A/ O	Item OPT70 or MOD70	Required (R) or Standard (S) or Optional (A or O) equipment	Weight per unit lb (kg)	Arm in. (m)
01 - Specific optional equipment				
S	0212-11	Mexico certification markings SOCATA	/	/

SECTION 7

Description

No specifics

SECTION 8

Handling, servicing and maintenance

No specifics

Intentionally left blank

SUPPLEMENT
GARMIN TAWS system
Table of contents

	Page
1 - General	9.49.2
2 - Limitations	9.49.2
3 - Emergency procedures	9.49.3
4 - Normal procedures	9.49.4
5 - Performance	9.49.6
6 - Weight and balance	9.49.6
7 - Description	9.49.7
8 - Handling, servicing and maintenance	9.49.14

SECTION 1

General

This supplement is intended to inform the pilot about the equipment limitations, description and operations necessary for operation when the airplane is equipped with the option GARMIN TAWS system.

The TAWS function enables to detect if the airplane path is in compliance with the overflow terrain relief.

SECTION 2

Limitations

The limitations hereafter supplement or replace those of the standard airplane described in section 2 Limitations of the basic POH when the airplane is equipped with the option GARMIN TAWS system.

The TAWS function provides terrain proximity alerting and detection to the pilot. It must not be used for airplane vertical and horizontal navigation.

AC 2318 recommendation : in order to avoid unwillingly warnings, TAWS function must be inhibited for any landing on a terrain which is not mentioned in the data base.

The use of the terrain awareness warning and terrain display functions is prohibited during QFE (atmospheric pressure at airport elevation) operations.

■ >> *Airplane equipped with GARMIN flight deck as standard*

The GARMIN Integrated Flight Deck Pilot's Guide mentioned in section 2 Limitations of the basic POH, as applicable, or any further edition applicable to the latter, shall be readily available to the pilot, whenever the operation of TAWS system is predicted.

■ >> *Airplane retrofitted with GARMIN G1000 NXi flight deck (MOD70-0539-00)*

The GARMIN G1000 NXi Integrated Flight Deck Pilot's Guide for the TBM850/900 P/N 190-02348-00 or any further edition applicable to the latter, shall be readily available to the pilot, whenever the operation of TAWS system is predicted.

SECTION 3**Emergency procedures**

The emergency procedures hereafter supplement or replace those of the standard airplane described in section 3 Emergency procedures of the basic POH when the airplane is equipped with the option GARMIN TAWS system.

TAWS FAIL annunciation

The TAWS function is not operational.

SECTION 4

Normal procedures

The normal procedures hereafter supplement or replace those of the standard airplane described in section 4 Normal Procedures of the basic POH when the TBM airplane is equipped with the option GARMIN TAWS system.

Before takeoff

- "TAWS System Test OK" voice message Heard
End of procedure.

4.1 - Warnings of the TAWS function

"PULL UP" voice alert

PULL UP PFD/MFD alert annunciation and **PULL UP** MFD pop-up alert light ON.

- 1 - Level the wings.
- 2 - TRQ Maximum
- 3 - Choose the optimum rate of climb adapted to airplane configuration and speed, until the warning disappears.

End of procedure.

"Terrain Terrain, Pull up Pull up", "Obstacle Obstacle, Pull up Pull up", voice alerts

PULL UP PFD/MFD alert annunciation and **TERRAIN/OBSTACLE - PULL UP** MFD pop-up alert light ON.

- 1 - Adjust airplane path in order to make the warning disappear.

End of procedure.

4.2 - Cautions of the TAWS function

"Caution terrain", "Caution obstacle",
"Too low terrain" voice alerts

TERRAIN PFD/MFD alert annunciation and **CAUTION TERRAIN/OBSTACLE**
or **TOO LOW TERRAIN** MFD pop-up alerts light ON.

- 1 - Adjust airplane path in order to make the warning disappear.

End of procedure.

"Don't sink" voice alert

TERRAIN PFD/MFD alert annunciation and **DON'T SINK** MFD pop-up alert
light ON.

- 1 - Re-establish a positive rate of climb.

End of procedure.

"Sink rate" voice alert

TERRAIN PFD/MFD alert annunciation and **SINK RATE** MFD pop-up alert light
ON.

- 1 - Reduce rate of descent.

End of procedure.

SECTION 5 Performance

Installation and operation of GARMIN TAWS system do not change the basic performance of the airplane described in section 5 Performance of the basic POH.

SECTION 6 Weight and balance

The weight and balance hereafter supplement or replace those of the standard airplane described in section 6 Weight and balance of the basic POH when the airplane is equipped with the option GARMIN TAWS system.

S/ R/ A/ O	Item OPT70 or MOD70	Required (R) or Standard (S) or Optional (A or O) equipment	Weight per unit lb (kg)	Arm in. (m)
34 - Navigation				
A	0176-00 Version F	TAWS system GARMIN	/	/

SECTION 7

Description

Information hereafter supplement or replace those of the standard airplane described in section 7 Description of the basic POH when the TBM airplane is equipped with the option GARMIN TAWS system.

>> *Airplane with G3000 Flight deck (MOD70-0476-00)*

TAWS-B terrain and obstacle alerts

- Alerts include visual annunciations and voice alerts.
- Alerts are accompanied by visual annunciation on PFD's and pop-up alerts on either Touchscreens Controllers
- Pilot acknowledges the Alert on the Touchscreen Controller

Voice alerts inhibiting

- TAWS Alerts can be inhibited by the pilot selecting Inhibit TAWS on Touchscreens Controllers
- Discretion should be used when inhibiting alerts and the system should be enabled when appropriate.

>> *All*

The TAWS function has 7 modes.

1. Forward Looking Terrain Avoidance alert

The Forward Looking Terrain Avoidance (FLTA) alert is used by TAWS and is composed of :

- **Reduced Required Terrain Clearance and Reduced Required Obstacle Clearance**

Reduced Required Terrain Clearance (RTC) and Reduced Required Obstacle Clearance (ROC) alerts are issued when the airplane flight path is above terrain, yet is projected to come within the minimum clearance values in table 9.49.1. When an RTC or ROC alert is issued, a potential impact point is displayed on the TAWS Page.

- **Imminent Terrain Impact and Imminent Obstacle Impact**

Imminent Terrain Impact (ITI) and Imminent Obstacle Impact (IOI) alerts are issued when the airplane is below the elevation of a terrain or obstacle cell in the airplane's projected path. ITI and IOI alerts are accompanied by a potential impact point displayed on the TAWS Page. The alert is annunciated when the projected vertical flight path is calculated to come within minimum clearance altitudes in table 9.49.1.

Phase of flight	Minimum Clearance Altitude Level Flight (ft)	Minimum Clearance Altitude Descending (ft)
Enroute	700	500
Terminal	350	300
Approach	150	100
Departure	100	100

Table 9.49.1 - Minimum Terrain and Obstacle Clearance values for FLTA alerts

During the final approach phase of flight, FLTA alerts are automatically inhibited when the airplane is below 200 feet AGL while within 0.5 Nm of the approach runway or below 125 feet AGL while within 1.0 Nm of the runway threshold.

Pilot's Operating Handbook

The aural/displayed messages associated with the FLTA function are described in the table 9.49.2.

Alert Type	PFD/MFD TAWS Page Annunciation	MFD Map Page Pop-Up Alert	Aural Message
Reduced Required Terrain Clearance Warning (RTC) (Red)	PULL UP	TERRAIN - PULL UP	"Terrain, Terrain ; Pull up, Pull up"
Imminent Terrain Impact Warning (ITI) (Red)	PULL UP	TERRAIN AHEAD - PULL UP	"Terrain Ahead, Pull up ; Terrain Ahead, Pull up"
Reduced Required Obstacle Clearance Warning (ROC) (Red)	PULL UP	OBSTACLE - PULL UP	"Obstacle, Obstacle ; Pull up, Pull up"
Imminent Obstacle Impact Warning (IOI) (Red)	PULL UP	OBSTACLE AHEAD - PULL UP	"Obstacle Ahead, Pull up ; Obstacle Ahead, Pull up"
Reduced Required Terrain Clearance Caution (RTC) (Amber)	TERRAIN	CAUTION - TERRAIN	"Caution, Terrain ; Caution, Terrain"
Imminent Terrain Impact Caution (ITI) (Amber)	TERRAIN	TERRAIN AHEAD	"Terrain Ahead ; Terrain Ahead"
Reduced Required Obstacle Clearance Caution (ROC) (Amber)	TERRAIN	CAUTION - OBSTACLE	"Caution, Obstacle ; Caution, Obstacle"
Imminent Obstacle Impact Caution (IOI) (Amber)	TERRAIN	OBSTACLE AHEAD	"Obstacle Ahead ; Obstacle Ahead"

Table 9.49.2 - FLTA alerts

2. Premature descent alerting

A Premature Descent Alert (PDA) is issued when the system detects that the airplane is significantly below the normal approach path to a runway (Figure 9.49.1).

PDA alerting begins when the airplane is within 15 Nm of the destination airport. PDA alerting ends when the airplane is either :

- 0.5 Nm from the runway threshold
- or
- at an altitude of 125 feet AGL while within 1.0 Nm of the threshold.

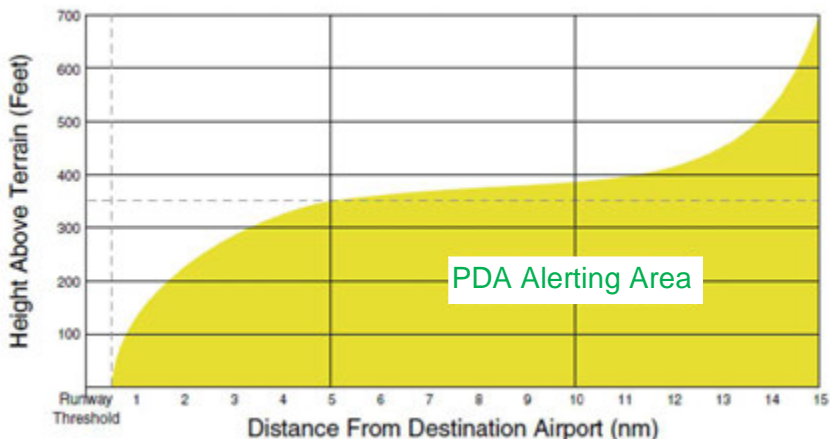

Figure 9.49.1 - PDA alerting threshold

The aural/displayed messages associated with the PDA function are described in the table 9.49.3.

Alert Type	PFD/MFD TAWS Page Annunciation	MFD Map Page Pop-Up Alert	Aural Message
Premature Descent Alert Caution (PDA) (Amber)	TERRAIN	TOO LOW - TERRAIN	"Too low, Terrain"

Table 9.49.3 - PDA alerts

3. Excessive descent rate alert

The purpose of the Excessive Descent Rate (EDR) alert is to provide suitable notification when the airplane is determined to be closing (descending) upon terrain at an excessive speed. Figure 9.49.2 shows the parameters for the alert as defined by TSO-C151b.

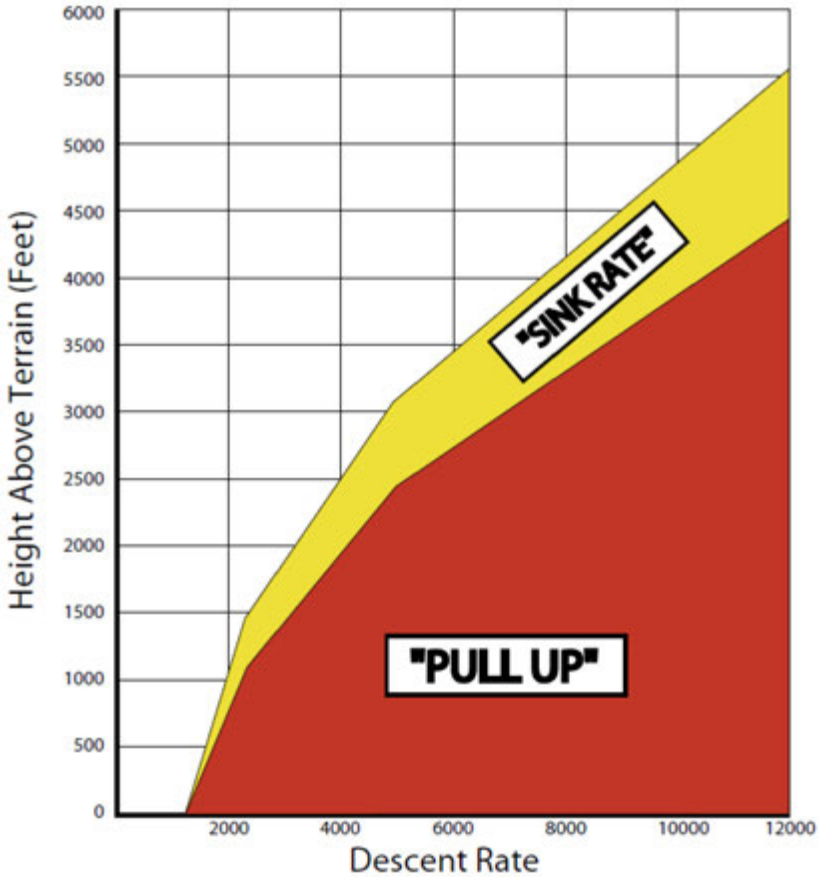

Figure 9.49.2 - Excessive Descent Rate Alert Criteria

The aural/displayed messages associated with the EDR function are described in the table 9.49.4.

Alert Type	PFD/MFD TAWS Page Annunciation	MFD Map Page Pop-Up Alert	Aural Message
Excessive Descent Rate Warning (EDR) (Red)	PULL UP	PULL UP	"Pull up"
Excessive Descent Rate Caution (EDR) (Amber)	TERRAIN	SINK RATE	"Sink rate"

Table 9.49.4 - EDR alerts

4. Negative climb rate after takeoff alert (NCR)

The purpose of the Negative Climb Rate (NCR) After Takeoff alert (also referred to as Altitude Loss After Takeoff) is to provide suitable alerts to the pilot when the system determines that the airplane is losing altitude (closing upon terrain) after takeoff. The aural message "Don't sink" is given for NCR alerts, accompanied by an annunciation and a pop-up terrain alert on the PFD's and Touchscreen Controllers. NCR alerting is only active when departing from an airport and when the following conditions are met :

- The height above the terrain is less than 700 feet.
- The distance from the departure airport is 5 Nm or less.
- The heading change from the heading at the time of departure is less than 110 degrees.

Pilot's Operating Handbook

Figure 9.49.3 shows two figures which illustrate the NCR alerting parameters as defined by TSO-C151b.

The NCR alert is issued when the altitude loss and height are within the range in the first figure, or when the sink rate (negative vertical speed) and height are within the range in the second figure.

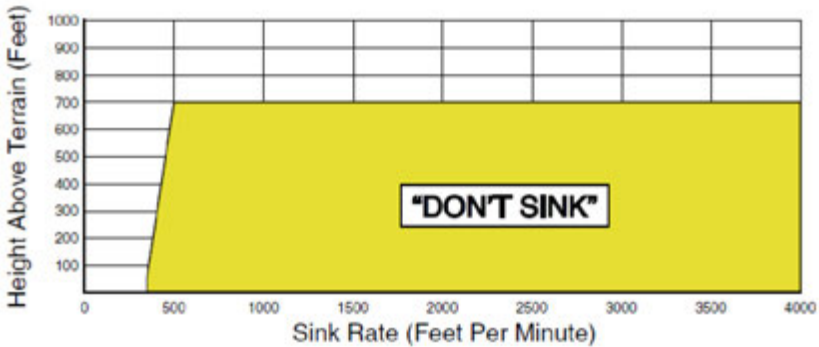
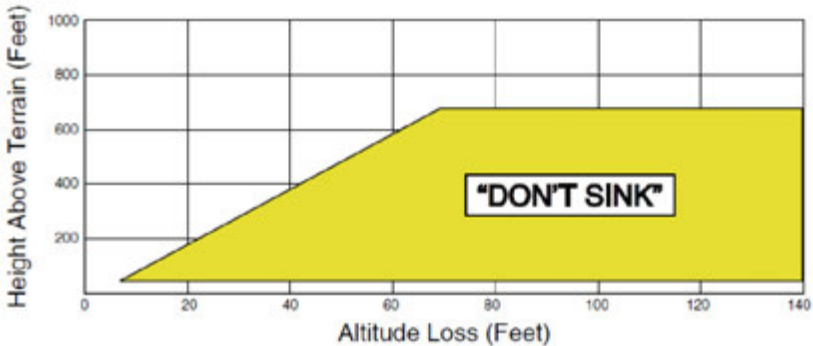

Figure 9.49.3 - Negative Climb Rate (NCR) Alert Criteria

The aural/displayed messages associated with the NCR function are described in the table 9.49.5.

Alert Type	PFD/MFD TAWS Page Annunciation	MFD Map Page Pop-Up Alert	Aural Message
Negative Climb Rate Caution (NCR) (Amber)	TERRAIN	DONT' SINK	"Don't sink"

Table 9.49.5 - NCR alerts

5. "FIVE-HUNDRED" aural alert, altitude voice callout (VCO)

The purpose of the aural alert message "Five-Hundred" is to provide an advisory alert to the pilot that the airplane is 500 feet above terrain. When the airplane descends within 500 feet of terrain, the aural message "Five-Hundred" is generated. There are no display annunciations or pop-up alerts that accompany the aural message.

6. TAWS not available alert

TAWS requires a 3-D GPS navigation solution along with specific vertical accuracy minimums. Should the navigation solution become degraded or if the airplane is out of the database coverage area, the annunciation TAWS N/A is generated in the annunciation window and on the TAWS Page. The aural message "TAWS Not Available" is generated. When the GPS signal is re-established and the airplane is within the database coverage area, the aural message "TAWS Available" is generated.

7. TAWS inhibit

TAWS also has an inhibit mode that deactivates the PDA/FLTA aural and visual alerts. Pilots should use discretion when inhibiting TAWS and always remember to enable the system when appropriate. Only the PDA and FLTA alerts are disabled in the inhibit mode.

SECTION 8

Handling, servicing and maintenance

Installation and operation of GARMIN TAWS system do not change the basic handling, servicing and maintenance procedures of the airplane described in section 8 Handling, Servicing and Maintenance of the basic POH.

SUPPLEMENT
GARMIN Synthetic Vision System
Table of contents

	Page
1 - General	9.50.2
2 - Limitations	9.50.2
3 - Emergency procedures	9.50.3
4 - Normal procedures	9.50.4
5 - Performance	9.50.5
6 - Weight and balance	9.50.5
7 - Description	9.50.5
8 - Handling, servicing and maintenance	9.50.6

SECTION 1

General

This supplement is intended to inform the pilot about the equipment limitations, description and operations necessary for operation when the TBM airplane is equipped with the option GARMIN Synthetic Vision System (SVS).

The SVS does not replace and is not intended to be used independently of the TAS and/or TAWS system(s).

The SVS does not replace and is not intended to be used independently of the horizontal and vertical primary flight instruments.

The SVS does not replace and is not intended to be used independently of the Course Deviation Indicator and the Vertical Deviation Indicator.

SECTION 2

Limitations

The limitations hereafter supplement or replace those of the standard airplane described in section 2 Limitations of the basic POH when the TBM airplane is equipped with the option GARMIN Synthetic Vision System.

The following document, or any further edition applicable to the latter, shall be readily available to the pilot, whenever operation of the SVS is predicted :

>> *Airplane equipped with G1000 Flight deck (MOD70-0176-00)*

- GARMIN Integrated Flight Deck Pilot's Guide, No. 190-00709-05 or its latest revision.

>> *Airplane equipped with G1000 Nxi Flight deck (MOD70-0539-00)*

- GARMIN Integrated Flight Deck Pilot's Guide, No. 190-02218-XX at its latest revision.

>> *Airplane retrofitted with GARMIN G1000 NXi Flight deck (MOD70-0539-00)*

- GARMIN G1000 NXi Integrated Flight Deck Cockpit Pilot's Guide for the TBM850/900 P/N 190-02348-00 or any later revision as applicable.

>> *Airplane equipped with G3000 Flight deck (MOD70-0476-00)*

- GARMIN Integrated Flight Deck Pilot's Guide, No. 190-02046-XX at its latest revision.

The use of the Synthetic Vision System display elements alone for airplane control without reference to the GARMIN system primary flight instruments is prohibited.

Pilot's Operating Handbook

The use of the Synthetic Vision System alone for vertical and/or horizontal navigation, or obstacle or terrain avoidance is prohibited.

Pathway boxes must be selected OFF when flying an instrument approach. Turn Pathways OFF when ACTIVATE VECTORS-TO-FINAL, ACTIVATE APPROACH is selected, or the airplane is established on any segment of the approach.

The use of the Synthetic Vision System traffic display alone to avoid other airplane is prohibited.

The Terrain Database has an area of coverage from North 75° latitude to South 60° latitude in all longitudes.

SECTION 3**Emergency procedures**

The emergency procedures hereafter supplement or replace those of the standard airplane described in Section 3 Emergency Procedures of the basic Pilot's Operating Handbook when the TBM airplane is equipped with the option GARMIN Synthetic Vision System.

Inconsistent display between SVS and GARMIN system primary flight instruments

>> *Airplane with G1000 Flight deck (MOD70-0176-00)*

From PFD display unit

- PFD softkey Press
- SYN VIS softkey Press
- SYN TERR softkey Press to disable
- SVS is removed from the PFD Verify

>> *Airplane with G1000 Nxi Flight deck (MOD70-0539-00)*

From PFD display unit

- PFD OPT softkey Press
- SVT softkey Press
- Terrain softkey Press to disable
- SVS is removed from the PFD Verify

■ >> *Airplane with G3000 Flight deck (MOD70-0476-00)*

From PFD display unit

- PFD Settings softkey Press
- Attitude Overlays softkey Press
- Synthetic Terrain softkey Press to disable
- SVS is removed from the PFD Verify

>> *All*

Use GARMIN system primary displays for navigation and airplane control.

SECTION 4

Normal procedures

The normal procedures hereafter supplement or replace those of the standard airplane described in section 4 Normal procedures of the basic POH when the TBM airplane is equipped with the option GARMIN Synthetic Vision System.

▲ CAUTION ▲

SVS information is not a substitute for standard course and altitude deviation information provided by the CDI, VSI, VDI and the primary flight instruments, as well as for the Traffic Advisory System (TAS) or the Terrain Awareness Warning System (TAWS).



SVS activation

Refer to GARMIN Integrated Flight Deck Pilot's Guide, as applicable, listed in section 2 Limitations of this supplement for further information.

SECTION 5

Performance

Installation and operation of GARMIN Synthetic Vision System do not change the basic performance of the airplane described in Section 5 Performance of the basic POH.

SECTION 6

Weight and balance

The weight and balance hereafter supplement or replace those of the standard airplane described in Section 6 Weight and balance of the basic POH when the airplane is equipped with the option GARMIN Synthetic Vision System.

S/ R/ A/ O	Item OPT70 or MOD70	Required (R) or Standard (S) or Optional (A or O) equipment	Weight per unit lb (kg)	Arm in. (m)
34 - Navigation				
A	0226-00	Synthetic Vision System	GARMIN	/

SECTION 7

Description

Information hereafter supplement or replace those of the standard airplane described in section 7 Description of the basic POH when the airplane is equipped with the option GARMIN Synthetic Vision System.

SVS provides additional features on the primary flight display (PFD) - refer to GARMIN Integrated Flight Deck Pilot's Guide, as applicable, listed in section 2 Limitations of this supplement for further information.

SECTION 8

Handling, servicing and maintenance

Installation and operation of GARMIN Synthetic Vision System do not change the basic handling, servicing and maintenance procedures of the airplane described in section 8 Handling, servicing and maintenance of the basic POH.

SUPPLEMENT**GARMIN GSR 56 weather datalink and satellite phone****Table of contents**

	Page
1 - General	9.56.2
2 - Limitations	9.56.2
3 - Emergency procedures	9.56.4
4 - Normal procedures	9.56.4
5 - Performance	9.56.7
6 - Weight and balance	9.56.7
7 - Description	9.56.8
8 - Handling, servicing and maintenance	9.56.9

SECTION 1

General

This supplement is intended to inform the pilot about the equipment limitations, description and operations necessary for operation when the TBM airplane is equipped with the option GARMIN GSR 56 weather datalink and satellite phone.

Unless otherwise mentioned, whenever a G1000 system is called in this supplement it concerns either a G1000 system or a G1000 NXi system.

SECTION 2

Limitations

The limitations hereafter supplement or replace those of the standard airplane described in section 2 Limitations of the basic POH when the TBM airplane is equipped with the option GARMIN GSR 56 weather datalink and satellite phone.

The GARMIN Integrated Flight Deck Pilot's Guide mentioned in section 2 Limitations of the basic POH (G1000 or G3000 as standard) or of the POH supplement (G1000 NXi retrofit), as applicable, or any further applicable edition, shall be readily available to the pilot, whenever the operation of GARMIN GSR 56 weather datalink and satellite phone is predicted.

Satellite phone functions

▲ WARNING ▲

Use of phone by PIC prohibited during all airplane operations



>> *Airplane with G1000 Flight deck*

- It is forbidden to activate Pilot In Command on-side GMA TEL button as long as the airplane is in the air or moving on the ground.
- Only the Pilot In Command cross side GMA TEL input can be activated at all time of flight for the front passenger and passengers to have the GSR 56 telephone audio functions.

>> *Airplane with G3000 Flight deck*

- It is forbidden to activate TEL button on Pilot Tab (located in NAV COM/Audio & Radios page) on GTC Touchscreen Controllers as long as the airplane is in the air or moving on the ground.

- Only the TEL button, on Copilot and Pass Tabs (located in NAV COM/Audio & Radios page) on GTC Touchscreen Controllers can be activated at all time of flight for the front passenger and passengers to have the GSR 56 telephone audio functions.

>> All

Weather datalink functions

- The GSR 56 weather datalink is only an advisory weather source, it does not relieve the pilot to comply with the applicable operational regulation in terms of flight preparation especially with regard to the use of an approved weather and NOTAM sources during flight planning.

International telecommunication regulation

The GSR 56 is a telecommunication device approved under FCC ID Q639522B and registered by the ITU (International Telecommunication Union) for international use according to the GMPCS-MoU.

The receiver transmitter RF module embedded in the GSR 56 is a 9522 B manufactured by Iridium Satellite LLC.

Terms of use are subject to changes and are available from the ITU website.

2.1 - Placards

Under L.H. front side window, under instruction plate

I4T13207AAA MA4200

USE OF PHONE BY PIC PROHIBITED DURING ALL AIRCRAFT OPERATIONS

SECTION 3

Emergency procedures

Installation and operation of GARMIN GSR 56 weather datalink and satellite phone do not change the basic emergency procedures of the airplane described in section 3 Emergency procedures of the basic POH.

SECTION 4

Normal procedures

The normal procedures hereafter supplement or replace those of the standard airplane described in section 4 Normal Procedures of the basic POH when the TBM airplane is equipped with the option GARMIN GSR 56 weather datalink and satellite phone.

Normal operating procedures of the GARMIN GSR 56 weather datalink and satellite phone system are outlined in the GARMIN Integrated Flight Deck Pilot's Guide.

■ >> Airplane with G1000 Flight deck

Before starting engine

On L.H. GMA audio panel

- 1 - TEL button OFF

End of procedure.

Before starting a phone call in flight

On L.H. GMA audio panel

- 1 - TEL button OFF

If rear passengers intend to take part in a phone call :

- 2 - CABIN button or PASS ICS button OFF
2 types of wording may exist for the same button

If front passenger intends to take part in a phone call :

- 3 - INTRCOM button or CREW ICS button OFF
2 types of wording may exist for the same button

On R.H. GMA audio panel

- 4 - TEL button ON

If rear passengers intend to take part in a phone call :

- 5 - CABIN button or PASS ICS button ON
2 types of wording may exist for the same button

End of procedure.

>> Airplane with G3000 Flight deck

Before starting engine

■ In one of the GTC's NAV COM / Audio & Radios / pilot Tab

1 - TEL button OFF

End of procedure.

Before starting a phone call in flight

■ In one of the GTC's NAV COM / Audio & Radios / pilot Tab

1 - TEL button OFF

If passengers intend to take part into a phone call :

In one of the GTC's NAV COM / Intercom Page

2 - Pilot/Passenger Link Arrow OFF

If front passenger intends to take part into a phone call :

In one of the GTC's NAV COM / Intercom Page

3 - Pilot/Copilot Link Arrow OFF

■ In one of the GTC's NAV COM / Audio & Radios / copilot Tab

4 - TEL button ON
if necessary, switch off Sync to Pilot function

If passengers intend to take part into a phone call :

■ In one of the GTC's NAV COM / Audio & Radios / Pass Tab

5 - TEL button ON
if necessary, switch off Sync to Pilot function

End of procedure.

SECTION 5

Performance

Installation and operation of GARMIN GSR 56 weather datalink and satellite phone. do not change the basic performance of the airplane described in section 5 Performance of the basic POH.

SECTION 6

Weight and balance

The weight and balance hereafter supplement or replace those of the standard airplane described in section 6 Weight and balance of the basic POH when the airplane is equipped with the option GARMIN GSR 56 weather datalink and satellite phone.

S/ R/ A/ O	Item OPT70 or MOD70	Required (R) or Standard (S) or Optional (A or O) equipment	Weight per unit lb (kg)	Arm in. (m)
23 - Communication				
A	0331-23	Weather datalink and satellite phone system GSR 56	GARMIN 3.82 (1.736)	58.03 (1.474)

SECTION 7

Description

Information hereafter supplement or replace those of the standard airplane described in section 7 Description of the basic POH when the airplane is equipped with the option GARMIN GSR 56 weather datalink and satellite phone.

GARMIN GSR 56 weather datalink and satellite phone system provides airborne low speed datalink and voice communication capability to Integrated Flight Deck system excluding any voice mail function. GSR 56 weather datalink and satellite phone system contains a transceiver that operates on the Iridium Satellite network.

The weather information are displayed on the MFD maps and on the PFD inset map.

■ >> *Airplane with G1000 Flight deck*

The satellite phone interface is embedded in the MFD : Phone communication and SMS can be received and sent through the dedicated pages on the MFD.

The controls for the MFD are located on both the MFD bezel and the MFD control unit.

The telephone audio including the incoming call ringing is controlled by the TEL button on the GMA audio panels and can be played in the pilot, front passenger and passengers headphones.

■ >> *Airplane with G3000 Flight deck*

■ The satellite phone interface is embedded in the Touchscreen Controllers : Phone communication and SMS can be received and sent through the dedicated pages on the Touchscreen Controllers.

■ The telephone audio including the incoming call ringing is controlled by the Touchscreen controllers & GMA audio processor and can be played in the pilot, front passenger and passengers headphones.

■ >> *All*

Although it is possible to leave a message when calling the airplane, as voice mail communication is not supported by the GSR 56 :

- it is not possible to access the GSR 56 voice mail from the airplane
- there is no indication on the Integrated Flight Deck system when a new message has been left on the GSR 56 voice mail.

SECTION 8

Handling, servicing and maintenance

Installation and operation of GARMIN GSR 56 weather datalink and satellite phone. do not change the basic handling, servicing and maintenance procedures of the airplane described in section 8 Handling, Servicing and Maintenance of the basic POH.

Intentionally left blank

SUPPLEMENT
Brazil specifics
Table of contents

	Page
1 - General	9.59.2
2 - Limitations	9.59.2
3 - Emergency procedures	9.59.13
4 - Normal procedures	9.59.13
5 - Performance	9.59.13
6 - Weight and balance	9.59.13
7 - Description	9.59.14
8 - Handling, servicing and maintenance	9.59.14

SECTION 1 General

This supplement is intended to inform the pilot about the airplane specifics, among others those required by the relevant Certification Authorities (limitations, description and operations necessary to the operation of the TBM airplane).

SECTION 2 Limitations

The limitations hereafter supplement or replace those of the standard airplane described in section 2 Limitations of the basic POH.

2.5 - Weight and C.G. limits

Weight limits

>> *With 4-seat accommodation*

- in rear part of pressurized cabin : 396 lbs (180 kg), with small or large net (see sketch below)

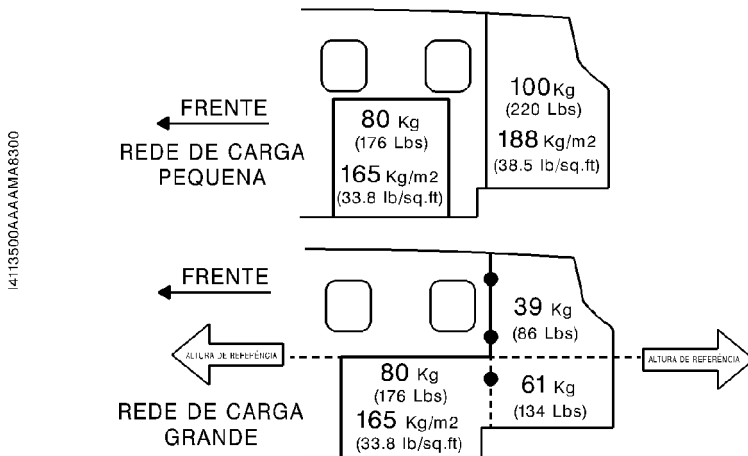

Figure 2.5.1 - Baggage limits

2.6 - Operation limits

When operating the VHF-COMM system in Brazilian air space, the selection of 8.33 kHz in the channels spacing can cause the loss of communication with the Air Traffic Control (ATC).

GNSS (GPS/SBAS) navigation system limitations

In accordance with Brazilian IS 21-013A, use of GNSS/GPS is prohibited under IFR unless other means of navigation, suitable and approved for the intended route, are installed and operational. It must be possible - at any point along the route - to navigate to the destination or alternate, using such means.

The SBAS functionality is not available in Brazil, therefore operations that require such functionality, such as GNSS vertical navigation modes, are prohibited in Brazilian airspace.

2.9 - Placards

On pressurized baggage compartment partition wall

100 kg MÁXIMO

**É DE RESPONSABILIDADE DO PILOTO
CHECAR SE TODA BAGAGEM ESTÁ
ADEQUADAMENTE SEGURA.
PARA INSTRUÇÕES DE CARREGAMENTO
CONSULTAR A SEÇÃO DE PESO E
BALANCEAMENTO DO MANUAL DE VÔO**

For the small cargo net, on frame C13bis

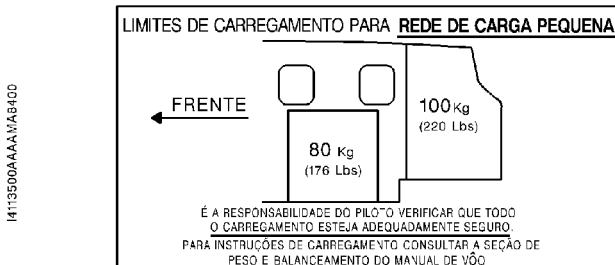

For the large cargo net, on R.H. side upholstery panel, in the rear baggage compartment

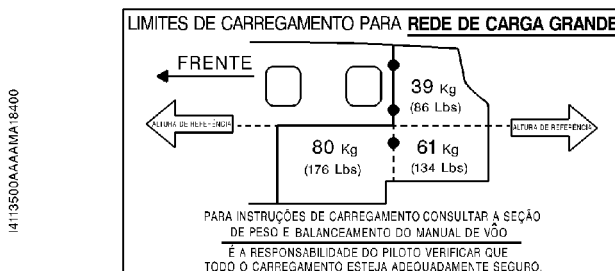

On FWD baggage compartment door frame, non pressurized

50 kg MÁXIMO

**PARA INSTRUÇÕES DE CARREGAMENTO
CONSULTAR A SEÇÃO DE PESO E
BALANCEAMENTO DO MANUAL DE VÔO**

Pilot's Operating Handbook

Near fuel tank caps



On internal face of L.H. engine cowling



On rear passenger's table casing

A MESA DEVERÁ ESTAR RECOLHIDA PARA DECOLAGEM E POUSO

On nose gear door

I4112001AAACIMAB100

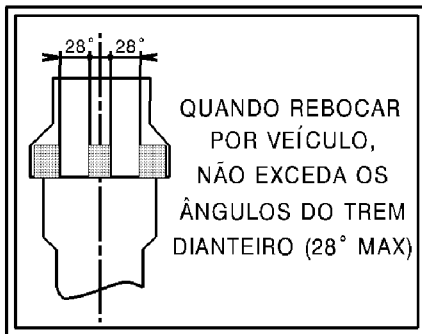

On engine cowling, in front of compartment door

**- TOMADA EXTERNA
- 28 VOLTS D.C. NOMINAL
- 800 AMPS
CAPACIDADE MÍNIMA PARA PARTIDA
- NÃO EXCEDA 1000 AMPS**

On pilot door - External side, if installed

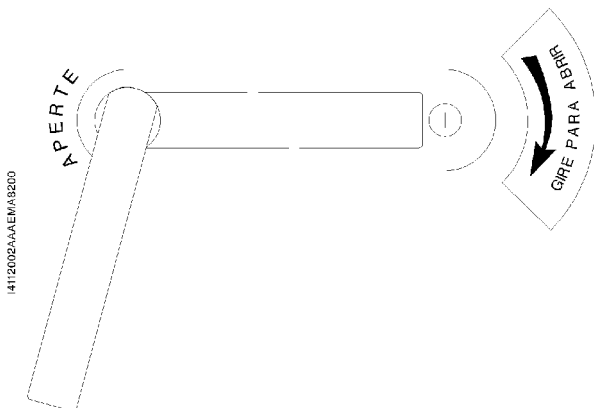

I4112002AAAEIA3200

Pilot's Operating Handbook

On access door - External side

I4112002AAAEMR6300



On outer fuselage skin aft of access door and in the cabin forward of access door

I4112002AAAIDMAB400



On access door - Internal side

I4112002AAAIDMAB400



**ATENÇÃO: DESTRAVAR ANTES
DE OPERAR A MANOPLA**

**GIRE A MANOPLA
PARA ABRIR** ↑

Pilot's Operating Handbook

On R.H. access door jamb

I4113400AAA8BMA8200



On R.H. side at front seat level and on the first rear passengers masks container (R.H. side on the ceiling)

I4113400AAA8BMA8300

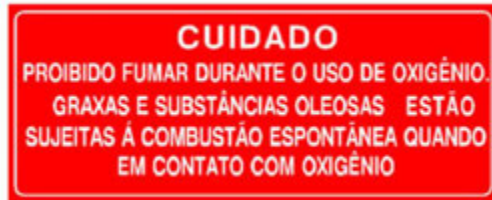

On rear passengers masks containers

I4113400AAA8BMA8400



On the oxygen service door

I4112400AAAAM8200

**ABASTECIMENTO DE OXIGÊNIO.
NÃO USE LUBRIFICANTES**

>> *Airplanes equipped with Lavatory compartment (Post-MOD70-0505-25)*

On fixed panel, cabin side

I4113200AAAAM/A8300

A DIVISÓRIA DEVE ESTAR RECOLHIDA DURANTE A DECOLAGEM E O POUSO

On fixed panel, toilet side

I4113200AAAAM/A8000

**O ASSENTO DO SANITÁRIO NÃO DEVE ESTAR
OCUPADO DURANTE A DECOLAGEM E O POUSO**

**FECHE E TRAVE A TAMPA DO SANITÁRIO
QUANDO NÃO ESTIVER EM USO**

**NÃO PENDURE OU MANTENHA OBJETOS
SOBRE O SANITÁRIO OU NA DIVISÓRIA**

**A DIVISÓRIA DEVE ESTAR RECOLHIDA
DURANTE A DECOLAGEM E O POUSO**

**OS FONES DE OUVIDO DEVEM SER
UTILIZADOS QUANDO A
DIVISÓRIA ESTIVER ESTENDIDA**

Pilot's Operating Handbook

On access door, cabin side and toilet side

I4113200AAA.MMA8200



Behind access door, cabin side and toilet side

I4113200AAA.MMA18200



Front face of lavatory compartment, near opening / closing switches

I4113200AAAAMMA18000



I4113200AAAAMMA8400



On the magazine rack and on side wall of storage volume

I4113200AAAAMMA18100

1,5 KG (3.3 LB)

>> *Airplanes equipped with Coat hanger (Post-MOD70-0557-25)*

On the upper edge of the L.H. Passenger access door panel

I4113200AAALMA8200

SOMENTE VESTUÁRIO

SECTION 3
Emergency procedures

No specifics

SECTION 4
Normal procedures

No specifics

SECTION 5
Performance

No specifics

SECTION 6
Weight and balance

The weight and balance hereafter supplement or replace those of the standard airplane described in section 6 Weight and balance of the basic POH.

S/ R/ A/ O	Item OPT70 or MOD70	Required (R) or Standard (S) or Optional (A or O) equipment	Weight per unit lb (kg)	Arm in. (m)
		01 - Specific optional equipment		
S	01004	Brazil certification markings	/	/

SECTION 7

Description

No specifics

SECTION 8

Handling, servicing and maintenance

No specifics

SUPPLEMENT
Lavatory compartment
Table of contents

	Page
1 - General	9.63.2
2 - Limitations	9.63.2
3 - Emergency procedures	9.63.7
4 - Normal procedures	9.63.8
5 - Performance	9.63.8
6 - Weight and balance	9.63.8
7 - Description	9.63.19
8 - Handling, servicing and maintenance	9.63.23

SECTION 1

General

This supplement is intended to inform the pilot about the equipment limitations, description and operations necessary for operation when the TBM airplane is equipped with the option lavatory compartment.

SECTION 2

Limitations

The limitations hereafter supplement or replace those of the standard airplane described in section 2 Limitations of the basic POH when the TBM airplane is equipped with the option lavatory compartment.

- toilet seat must not be occupied during take-off and landing
- divider must be stowed during take-off and landing
- headset shall be worn at all time when seat is occupied

■ >> From S/N 1000 to S/N 1269

2.9 - Placards

On fixed panel, cabin side

DIVIDER MUST BE STOWED DURING TAKE-OFF AND LANDING

14113200AAAHHMA6300

Pilot's Operating Handbook

On fixed panel, toilet side

14113200AAAUA16000

TOILET SEAT MUST NOT
BE OCCUPIED DURING
TAKE OFF AND LANDING
CLOSE AND LOCK TOILET COVER
WHEN NOT IN USE
DO NOT HANG OR STORE ITEMS
ON TOILET OR DIVIDER
DIVIDER MUST BE STOWED DURING
TAKE OFF AND LANDING
HEADSET MUST BE USED WHEN
DIVIDER IS DEPLOYED

On access door, cabin side and toilet side

14113200AAAUA8000

EMERGENCY
STOWAGE
REMOVE
COVER

Behind access door, cabin side and toilet side

14113200AAAUA18100

PUSH TO STOW

Inner face of toilet cover

I4113200AAAIIIA18200



Front face of lavatory compartment, near opening/closing switches

I4113200AAAIIIA8100



I4113200AAAIIIA8200



On the magazine rack

I4113200AAAIIIA8000

3.3 LBS (1,5 KG)

>> From S/N 1270

2.9 - Placards

On fixed panel, cabin side

I4113200AAAANMAB200

DIVIDER MUST BE STOWED DURING TAKE-OFF AND LANDING

On fixed panel, toilet side

I4113200AAAANMAB300

TOILET SEAT MUST NOT TO BE
OCCUPIED DURING TAKE-OFF
AND LANDING

CLOSE AND LOCK TOILET COVER
WHEN NOT IN USE

DO NOT HANG OR STORE ITEMS
ON TOILET OR DIVIDER

DIVIDER MUST BE STOWED DURING
TAKE-OFF AND LANDING

HEADSET MUST BE USED WHEN
DIVIDER IS DEPLOYED

On access door, cabin side and toilet side

I4113200AAAANMAB100



Behind access door, cabin side and toilet side

I4113200AAA1NMA8000



Inner face of toilet cover

I4113300AAA1MA8400



Front face of lavatory compartment, near opening/closing switches

I4113200AAA1MA8400

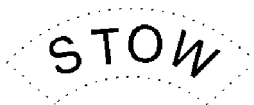

I4113200AAA1MA18000



On the magazine rack

I4113200AAA/IMA8300

1,5 kg - 3.3 lbs

SECTION 3

Emergency procedures

The emergency procedures hereafter supplement those of the standard airplane described in section 3 Emergency procedures of the basic POH.

3.10 - Pressurization and air conditioning

>> *Without v15 GARMIN software (Pre-MOD70-0407-00)*

CABIN ALTITUDE

Inform passengers to use emergency stowing of the divider and oxygen mask.

>> *With v15 GARMIN software (Post-MOD70-0407-00) or airplane with G3000 Flight deck (MOD70-0476-00)*

CABIN ALTITUDE and **USE OXYGEN MASK**

or

CABIN ALTITUDE and **USE OXYGEN MASK** and **EDM**

Inform passengers to use emergency stowing of the divider and oxygen mask.

Other procedures in the basic POH are unchanged.

SECTION 4

Normal procedures

The normal procedures hereafter supplement or replace those of the standard airplane described in section 4 Normal procedures of the basic POH when the TBM airplane is equipped with the option lavatory compartment.

BRIEFING to passengers to be performed before entering the airplane

Normal and Emergency stowing operations of the divider.

In case of depressurization : emergency stowing of the divider, use oxygen mask, and remain seated unless otherwise instructed by the crew.

The headset must be used when the divider is deployed to allow communication with the crew in case of emergency.

SECTION 5

Performance

Installation and operation of Lavatory compartment do not change the basic performance of the airplane described in section 5 Performance of the basic POH.

SECTION 6

Weight and balance

The weight and balance hereafter supplement or replace those of the standard airplane described in section 6 Weight and balance of the basic POH when the airplane is equipped with the option lavatory compartment.

6.1 - General

This paragraph is intended to provide the pilot with a simple and rapid means of determining weight and balance of the airplane when equipped with the lavatory compartment option.

▲ WARNING ▲

It is the pilot's responsibility to ensure that the airplane is properly loaded and the weight and balance limits are adhered to.



6.4 - Determining the new airplane empty weight and balance after the application of the lavatory compartment option

• NOTE •

The new empty weight determination after lavatory compartment installation shall be performed from the 6-seat configuration airplane characteristics

•

- 1) Record the basic empty weight (1a) and moment (1b) and CG (MAC %) (1c) from the last Weight and Balance Report in 6-seat configuration (see samples Figures 6.4.1 and 6.4.2 of the basic Pilot's Operating Handbook).
- 2) Compute the new empty weight (2a) and moment (2b) as sum of all above weights (1a) [removed equipment + installed equipment] and associated moments (1b) [removed equipment + installed equipment]
- 3) Compute the new empty weight arm (3) and CG (MAC %) (3c) using given formulas.
- 4) Report the new empty weight arm (3) and CG (MAC %) (3c) into the WEIGHT AND BALANCE FORM AND DIAGRAM of the airplane loading form in order to perform the weight and balance determination with the lavatory compartment installed.

■ >> From S/N 1000 to S/N 1159

Moment = Weight x Arm $CG (MAC \%) = \frac{(Arm (m) - 4.392)}{1.51} \times 100$

Item	Weight (kg)	Arm (m)	Moment (m.kg)	CG (MAC %)
Empty Weight (kg)	(1a)		(1b)	(1c)
Weight and moment variation after lavatory compartment option installation	+ 12		+ 86	
New empty weight (ready for cargo preparation)	(2a)	(3)	(2b)	(3c)

Moment = Weight x Arm $CG (MAC \%) = \frac{(Arm (in) - 172.93)}{59.45} \times 100$

Item	Weight (lbs)	Arm (in)	Moment (in.lbs)	CG (MAC %)
Empty Weight (lbs)	(1a)		(1b)	(1c)
Weight and moment variation after lavatory compartment option installation	+ 27		+ 7530	
New empty weight (ready for cargo preparation)	(2a)	(3)	(2b)	(3c)

Pilot's Operating Handbook

>> From S/N 1160

Moment = Weight x Arm $CG (MAC \%) = \frac{(Arm (m) - 4.392)}{1.51} \times 100$

Item	Weight (kg)	Arm (m)	Moment (m.kg)	CG (MAC %)
Empty Weight (kg)	(1a)		(1b)	(1c)
Weight and moment variation after lavatory compartment option installation without seat heating system	+ 19		+ 134	
or				
Weight and moment variation after lavatory compartment option installation with seat heating system	+ 18		+ 127	
New empty weight (ready for cargo preparation)	(2a)	(3)	(2b)	(3c)

Moment = Weight x Arm $CG (MAC \%) = \frac{(Arm (in) - 172.93)}{59.45} \times 100$

Item	Weight (lbs)	Arm (in)	Moment (in.lbs)	CG (MAC %)
Empty Weight (lbs)	(1a)		(1b)	(1c)
Weight and moment variation after lavatory compartment option installation without seat heating system	+ 42		+ 11643	
or				
Weight and moment variation after lavatory compartment option installation with seat heating system	+ 40		+ 11056	
New empty weight (ready for cargo preparation)	(2a)	(3)	(2b)	(3c)

Using the weight and balance form

▲ CAUTION ▲

Empty weight, arm and CG % position to be considered are the ones from the last weight and balance report issued after the lavatory compartment option installation.



Refer to POH section 6.4 using the weight and balance form procedure to determine the weight and balance of the airplane equipped with the lavatory compartment option together with the use of the loading form hereafter.

S/ R/ A/ O	Item OPT70 or MOD70	Required (R) or Standard (S) or Optional (A or O) equipment	Weight per unit lb (kg)	Arm in. (m)
25 - Equipment and furnishings				
O	0505-25C	Lavatory compartment	138.9 (63)	267.7 (6.799)
		Lavatory compartment carpet	28.7 (13)	211.4 (5.370)

Weight and balance form and diagram (m, kg) - only applicable if lavatory compartment is installed

■ >> From S/N 1000 to S/N 1159

Moment = Weight x Arm $CG (MAC\%) = \frac{(Arm (m) - 4.392)}{1.51} \times 100$

Item		Weight (kg)	Arm (m)	Moment (m.kg)	CG (MAC %)
Empty Weight (kg)					
Baggage FWD (< 50 kg)			3.250		
Front Seats (kg)			4.534		
Inter. Seats	-17 kg per seat removed		5.710		
	Pax				
Baggage AFT (< 100 kg)			7.695		
Zero Fuel Weight (< 2 736 kg)					
Fuel (kg)			4.820		
Ramp Weight (< 3 370 kg)					
Taxi Fuel (kg)			4.820		
Takeoff Weight (< 3 354 kg)					
Trip Fuel (kg)			4.820		
Landing Weight (< 3 186 kg)					

>> From S/N 1160

Moment = Weight x Arm $CG (MAC \%) = \frac{Arm (m) - 4.392}{1.51} \times 100$

Item	Weight (kg)	Arm (m)	Moment (m.kg)	CG (MAC %)
Empty Weight (kg)				
Baggage FWD (< 50 kg)		3.250		
Front Seats (kg)		4.534		
Inter. Seats	-15 kg per seat removed*	5.710		
	Pax			
Baggage AFT (< 100 kg)		7.695		
Zero Fuel Weight (< 2 736 kg)				
Fuel (kg)		4.820		
Ramp Weight (< 3 370 kg)				
Taxi Fuel (kg)		4.820		
Takeoff Weight (< 3 354 kg)				
Trip Fuel (kg)		4.820		
Landing Weight (< 3 186 kg)				

* Seats weights do not include seat heating system weight

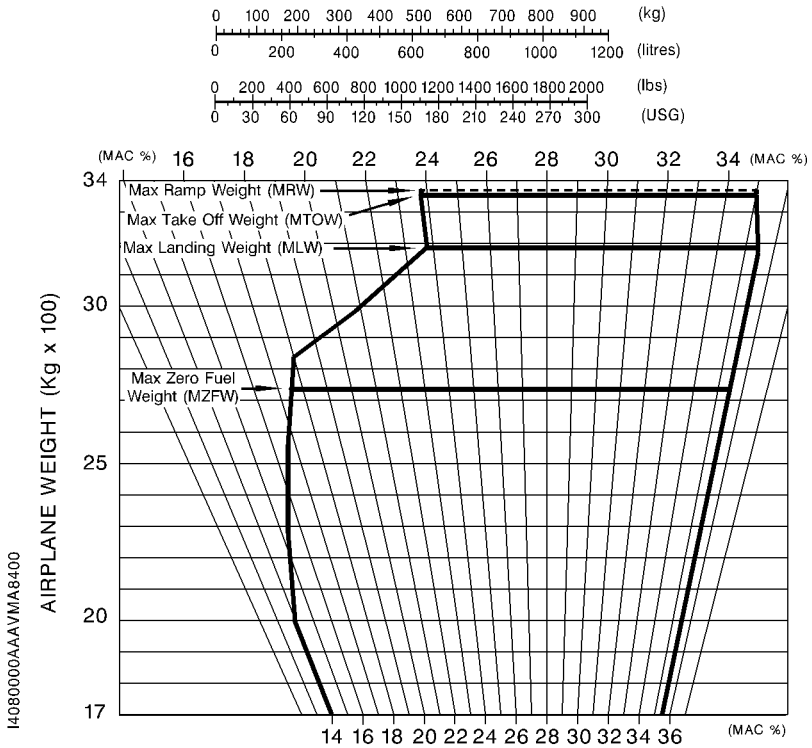

Figure 9.63.1 – Weight and Balance diagram

Weight and balance form and diagram (in, lbs) - only applicable if lavatory compartment is installed

■ >> From S/N 1000 to S/N 1159

Moment = Weight x Arm $CG (MAC \%) = \frac{(Arm (in) - 172.93)}{59.45} \times 100$

Item	Weight (lbs)	Arm (in)	Moment (in.lbs)	CG (MAC %)
Empty Weight (lbs)				
Baggage FWD (< 110 lbs)		128.0		
Front Seats (lbs)		178.5		
Inter. Seats	-37.5 lbs per seat removed	224.8		
	Pax			
Baggage AFT (< 220 lbs)		303.0		
Zero Fuel Weight (< 6 032 lbs)				
Fuel (lbs)		189.8		
Ramp Weight (< 7 430 lbs)				
Taxi Fuel (lbs)		189.8		
Takeoff Weight (< 7 394 lbs)				
Trip Fuel (kg)		189.8		
Landing Weight (< 7 024 lbs)				

Pilot's Operating Handbook

>> From S/N 1160

Moment = Weight x Arm

$$CG (MAC \%) = \frac{(Arm (in) - 172.93)}{59.45} \times 100$$

Item	Weight (lbs)	Arm (in)	Moment (in.lbs)	CG (MAC %)
Empty Weight (lbs)				
Baggage FWD (< 110 lbs)		128.0		
Front Seats (lbs)		178.5		
Inter. Seats	-33.1 lbs per seat removed *	224.8		
	Pax			
Baggage AFT (< 220 lbs)		303.0		
Zero Fuel Weight (< 6 032 lbs)				
Fuel (lbs)		189.8		
Ramp Weight (< 7 430 lbs)				
Taxi Fuel (lbs)		189.8		
Takeoff Weight (< 7 394 lbs)				
Trip Fuel (kg)		189.8		
Landing Weight (< 7 024 lbs)				

* Seats weights do not include seat heating system weight

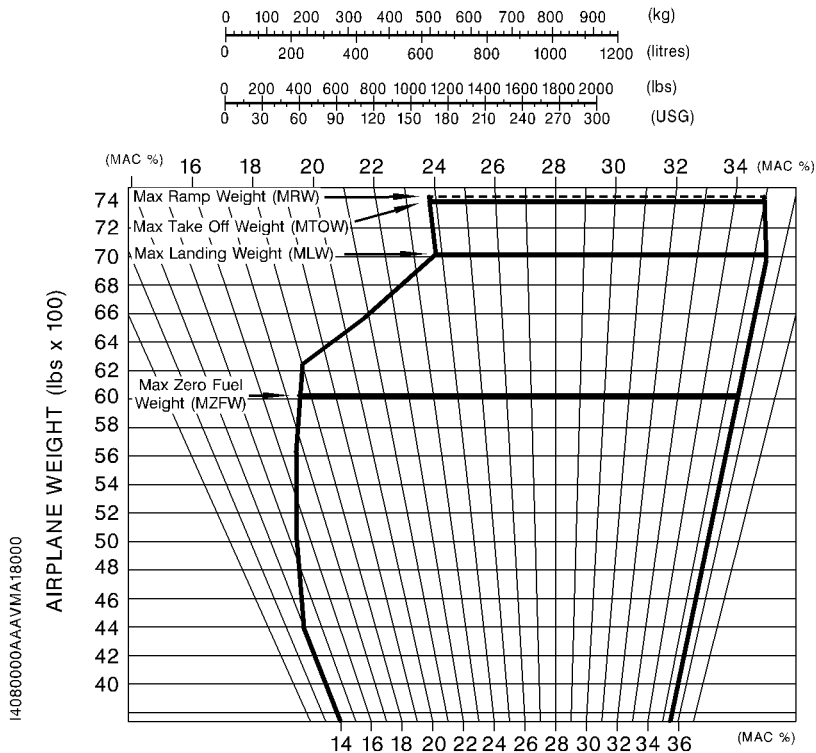

Figure 9.63.2 – Weight and Balance diagram

SECTION 7

Description

Information hereafter supplement or replace those of the standard airplane described in section 7 Description of the basic POH when the airplane is equipped with the option Lavatory compartment.

For operation, refer to equipment User's Guide.

The lavatory compartment is installed against right interior upholstery panel, facing large door. The lavatory compartment is installed at the place of the rear seats, removed to allow this installation. It is attached to the fuselage structure on the cabin floor, using the seats tracks with four pads and screws.

The lavatory compartment structure is made of composite panels.

The lavatory compartment assembly is composed of :

- A chemical toilet,
- Electrically deployable separating panels (divider),
- Two (2) actuating switches (DEPLOY, STOW),
- Two (2) emergency stowing buttons (PUSH TO STOW), accessible from inside or outside the lavatory compartment,
- One (1) mirror,
- One (1) electric power plug,
- One (1) headset allowing communication between the passenger and the crew.

When the lavatory compartment is not occupied, the divider is stored unfolded in the lavatory compartment structure.

A breaker integrated into the lavatory compartment structure protects its electrical system. The circuit breaker is only accessible when the lavatory compartment is removed.

Two (2) switches, located on the seat front face, left side, hidden when latching strap snap fastener is locked, control the deployment/stowing of the moveable parts of the divider.

Two (2) access doors (Velcro tape attached), located on each side of the fixed part of the divider, give access to the emergency stowing push button, allowing the emergency (manual) retraction of the divider, using the application of a vertical force (by hand) on the upper edge of the divider.

Electric connection of the system is performed via a power plug :

>> Without optional 12V power plugs (Pre-MOD70-0174-25)

- 28 volts

>> With optional 12V power plugs (Post-MOD70-0174-25)

- 12 volts

>> All

The power plug is located on the right hand side upholstery panel. Connection is only accessible when the lavatory compartment structure is unscrewed from the floor and moved slightly aside to access the plug.

Mirror is automatically illuminated during the deployment of the divider.

A safety anti pinching sensor stops the deployment of the divider in case an interference is detected.

To remove the chemical toilet system from the lavatory compartment structure, it is necessary to unlatch the toilet cover, remove the top frame, if installed then lift upward the forward face of the structure and pull out the toilet from the structure.

A storage volume on the left side of the toilet is accessible when toilet cover is up.

A magazine rack is located on the forward side of the fixed part of the divider.

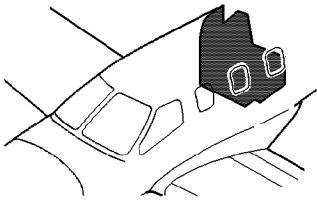

DEPLOYABLE SEPARATING
PANELS (DIVIDER)

EMERGENCY
STOWING BUTTON

DIVIDER
DEPLOYED

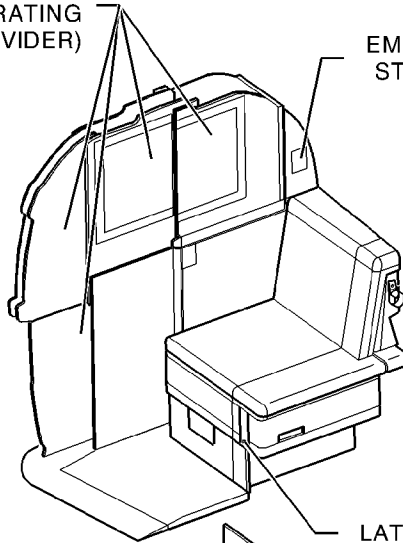

LATCHING STRAP

DIVIDER
STOWED

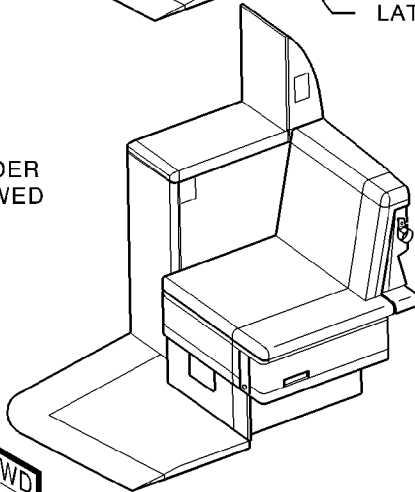

14252108AAA.BMA8100

Figure 9.63.3 (1/2) - Lavatory compartment

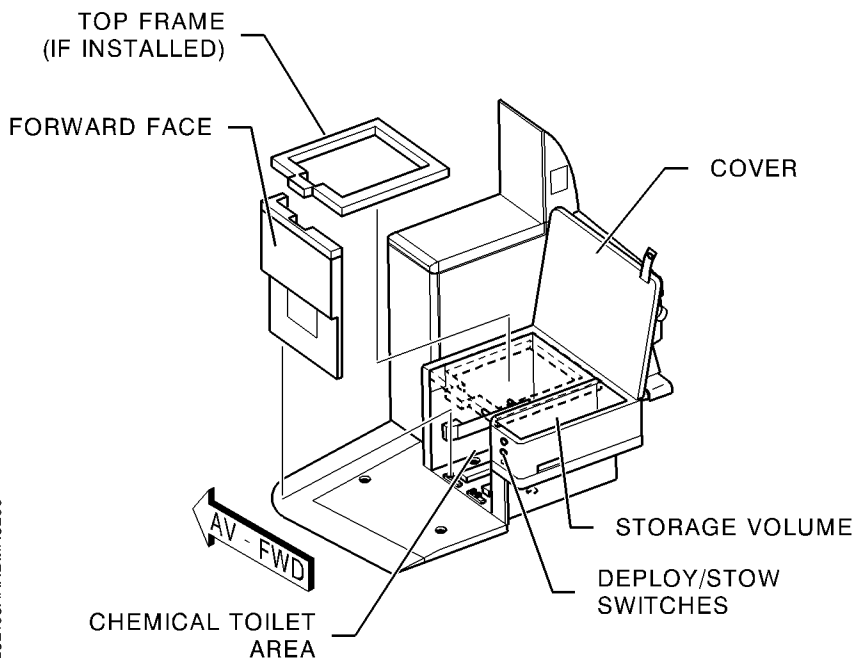
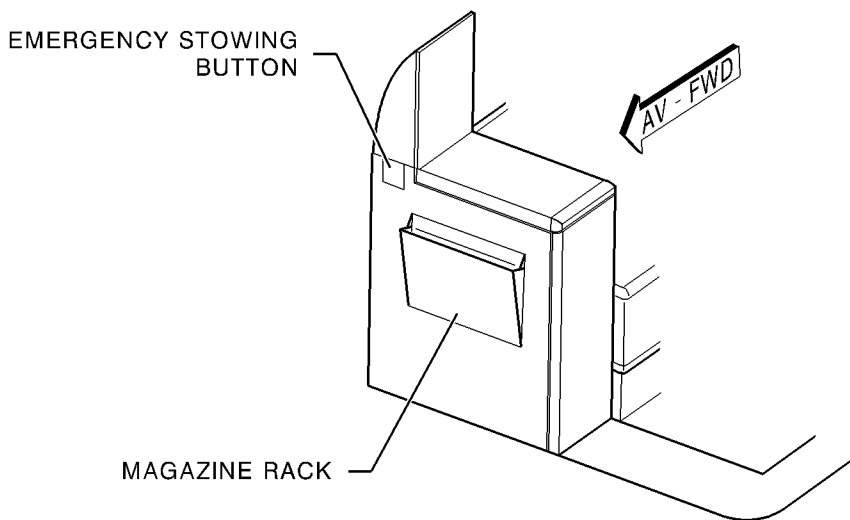

14252108AA.ABM/A8200

Figure 9.63.3 (2/2) - Lavatory compartment

SECTION 8

Handling, servicing and maintenance

Installation and operation of Lavatory compartment do not change the basic handling, servicing and maintenance procedures of the airplane described in section 8 Handling, servicing and maintenance of the basic POH.

Intentionally left blank